



**SPC BENCHMARK 1™
FULL DISCLOSURE REPORT**

**IBM CORPORATION
IBM STORWIZE® V3700 (*TURBO*)**

SPC-1 V1.14

Submitted for Review: April 18, 2014

Submission Identifier: A00143

First Edition – April 2014

THE INFORMATION CONTAINED IN THIS DOCUMENT IS DISTRIBUTED ON AN AS IS BASIS WITHOUT ANY WARRANTY EITHER EXPRESS OR IMPLIED. The use of this information or the implementation of any of these techniques is the customer's responsibility and depends on the customer's ability to evaluate and integrate them into the customer's operational environment. While each item has been reviewed by IBM Corporation for accuracy in a specific situation, there is no guarantee that the same or similar results will be obtained elsewhere. Customers attempting to adapt these techniques to their own environment do so at their own risk.

This publication was produced in the United States. IBM Corporation may not offer the products, services, or features discussed in this document in other countries, and the information is subject to change with notice. Consult your local IBM Corporation representative for information on products and services available in your area.

© Copyright IBM Corporation 2014. All rights reserved.

Permission is hereby granted to reproduce this document in whole or in part, provided the copyright notice as printed above is set forth in full text on the title page of each item reproduced.

Trademarks

SPC Benchmark-1, SPC-1, SPC-1 IOPS, SPC-1 LRT and SPC-1 Price-Performance are trademarks of the Storage Performance Council. IBM, Storwize and the IBM logo are trademarks or registered trademarks of IBM Corporation in the United States and other countries. All other brands, trademarks, and product names are the property of their respective owners.

Table of Contents

Audit Certification	vii
Audit Certification (cont.)	viii
Letter of Good Faith	ix
Executive Summary	10
Test Sponsor and Contact Information	10
Revision Information and Key Dates	10
Tested Storage Product (TSP) Description	10
Summary of Results	11
Storage Capacities, Relationships, and Utilization	12
Response Time – Throughput Curve	15
Response Time – Throughput Data	15
Priced Storage Configuration Pricing	16
Differences between the Tested Storage Configuration (TSC) and Priced Storage Configuration	16
Priced Storage Configuration Diagram	17
Priced Storage Configuration Components	18
Configuration Information	19
Benchmark Configuration (BC)/Tested Storage Configuration (TSC) Diagram	19
Storage Network Configuration	19
Host System(s) and Tested Storage Configuration (TSC) Table of Components	19
Benchmark Configuration/Tested Storage Configuration Diagram	20
Host System and Tested Storage Configuration Components	21
Customer Tunable Parameters and Options	22
Tested Storage Configuration (TSC) Description	22
SPC-1 Workload Generator Storage Configuration	22
ASU Pre-Fill	23
SPC-1 Data Repository	24
Storage Capacities and Relationships	24
SPC-1 Storage Capacities	24
SPC-1 Storage Hierarchy Ratios	25
SPC-1 Storage Capacity Charts	25
Storage Capacity Utilization	27
Logical Volume Capacity and ASU Mapping	28
SPC-1 Benchmark Execution Results	29
SPC-1 Tests, Test Phases, and Test Runs	29

“Ramp-Up” Test Runs.....	30
Primary Metrics Test – Sustainability Test Phase	30
SPC-1 Workload Generator Input Parameters	31
Sustainability Test Results File	31
Sustainability – Data Rate Distribution Data (MB/second)	31
Sustainability – Data Rate Distribution Graph	31
Sustainability – I/O Request Throughput Distribution Data	32
Sustainability – I/O Request Throughput Distribution Graph	32
Sustainability – Average Response Time (ms) Distribution Data	33
Sustainability – Average Response Time (ms) Distribution Graph	33
Sustainability – Response Time Frequency Distribution Data	34
Sustainability – Response Time Frequency Distribution Graph	34
Sustainability – Measured Intensity Multiplier and Coefficient of Variation.....	35
Primary Metrics Test – IOPS Test Phase.....	36
SPC-1 Workload Generator Input Parameters	36
IOPS Test Results File.....	36
IOPS Test Run – I/O Request Throughput Distribution Data	37
IOPS Test Run – I/O Request Throughput Distribution Graph.....	37
IOPS Test Run – Average Response Time (ms) Distribution Data	38
IOPS Test Run – Average Response Time (ms) Distribution Graph	38
IOPS Test Run –Response Time Frequency Distribution Data	39
IOPS Test Run –Response Time Frequency Distribution Graph.....	39
IOPS Test Run – I/O Request Information.....	40
IOPS Test Run – Measured Intensity Multiplier and Coefficient of Variation	40
Primary Metrics Test – Response Time Ramp Test Phase	41
SPC-1 Workload Generator Input Parameters	41
Response Time Ramp Test Results File.....	41
Response Time Ramp Distribution (IOPS) Data.....	42
Response Time Ramp Distribution (IOPS) Data (<i>continued</i>)	43
Response Time Ramp Distribution (IOPS) Graph	43
SPC-1 LRT™ Average Response Time (ms) Distribution Data.....	44
SPC-1 LRT™ Average Response Time (ms) Distribution Graph	44
SPC-1 LRT™ (10%) – Measured Intensity Multiplier and Coefficient of Variation	45
Repeatability Test	46
SPC-1 Workload Generator Input Parameters	46
Repeatability Test Results File	47
Repeatability 1 LRT – I/O Request Throughput Distribution Data.....	48
Repeatability 1 LRT – I/O Request Throughput Distribution Graph	48
Repeatability 1 LRT –Average Response Time (ms) Distribution Data	49

Repeatability 1 LRT –Average Response Time (ms) Distribution Graph.....	49
Repeatability 1 IOPS – I/O Request Throughput Distribution Data	50
Repeatability 1 IOPS – I/O Request Throughput Distribution Graph.....	50
Repeatability 1 IOPS –Average Response Time (ms) Distribution Data.....	51
Repeatability 1 IOPS –Average Response Time (ms) Distribution Graph	51
Repeatability 2 LRT – I/O Request Throughput Distribution Data.....	52
Repeatability 2 LRT – I/O Request Throughput Distribution Graph	52
Repeatability 2 LRT –Average Response Time (ms) Distribution Data	53
Repeatability 2 LRT –Average Response Time (ms) Distribution Graph.....	53
Repeatability 2 IOPS – I/O Request Throughput Distribution Data	54
Repeatability 2 IOPS – I/O Request Throughput Distribution Graph.....	54
Repeatability 2 IOPS –Average Response Time (ms) Distribution Data.....	55
Repeatability 2 IOPS –Average Response Time (ms) Distribution Graph	55
Repeatability 1 (LRT) Measured Intensity Multiplier and Coefficient of Variation.....	56
Repeatability 1 (IOPS) Measured Intensity Multiplier and Coefficient of Variation	56
Repeatability 2 (LRT) Measured Intensity Multiplier and Coefficient of Variation.....	56
Repeatability 2 (IOPS) Measured Intensity Multiplier and Coefficient of Variation	57
Data Persistence Test.....	58
SPC-1 Workload Generator Input Parameters	58
Data Persistence Test Results File	58
Data Persistence Test Results.....	59
Priced Storage Configuration Availability Date.....	60
Pricing Information.....	60
Tested Storage Configuration (TSC) and Priced Storage Configuration Differences.....	60
Anomalies or Irregularities	60
Appendix A: SPC-1 Glossary	61
“Decimal” (<i>powers of ten</i>) Measurement Units.....	61
“Binary” (<i>powers of two</i>) Measurement Units.....	61
SPC-1 Data Repository Definitions.....	61
SPC-1 Data Protection Levels	62
SPC-1 Test Execution Definitions	62
I/O Completion Types	64
SPC-1 Test Run Components.....	64
Appendix B: Customer Tunable Parameters and Options.....	65
Appendix C: Tested Storage Configuration (TSC) Creation	66
Storwize V3700 Configuration	66

Creat RAID10 Arrays and MDisks	66
Create the VDisks	66
Create the Host Paths.....	66
Assign Primary and Alternate Host Paths	66
Windows Configuration	66
Referenced Scripts.....	67
step1_mkranks.cyg.....	67
step2_mkvdisk.cyg.....	67
step3_mkhost.cyg	68
step4_mapfcs.cyg.....	68
mkdiskpart.cyg.....	68
dpmake.bat	69
Appendix D: SPC-1 Workload Generator Storage Commands and Parameters	71
ASU Pre-Fill.....	71
Primary Metrics, Repeatability and SPC-1 Persistence Tests	72
Appendix E: SPC-1 Workload Generator Input Parameters	73
spcstart1.bat	73
asufill.bat.....	73
spcstart2.bat	73
SPC-1 Persistence Test Run 2.....	73

AUDIT CERTIFICATION



Bruce McNutt
IBM Corporation
IBM ARC
650 Harry Road
San Jose, CA 96120

April 18, 2014

The SPC Benchmark 1™ Reported Data listed below for the IBM Storwize® V3700 (*Turbo*) was produced in compliance with the SPC Benchmark 1™ v1.14 Remote Audit requirements.

SPC Benchmark 1™ v1.14 Reported Data	
Tested Storage Product (TSP) Name: IBM Storwize® V3700 (<i>Turbo</i>)	
Metric	Reported Result
SPC-1 IOPS™	32,505.36
SPC-1 Price-Performance	\$3.80/SPC-1 IOPS™
Total ASU Capacity	10,307.992 GB
Data Protection Level	Protected 1 (<i>Mirroring</i>)
Total Price (including three-year maintenance)	\$123,616.18
Currency Used	U.S. Dollars
Target Country for availability, sales and support	USA

The following SPC Benchmark 1™ Remote Audit requirements were reviewed and found compliant with 1.14 of the SPC Benchmark 1™ specification:

- A Letter of Good Faith, signed by a senior executive.
- The following Data Repository storage items were verified by information supplied by IBM Corporation:
 - ✓ Physical Storage Capacity and requirements.
 - ✓ Configured Storage Capacity and requirements.
 - ✓ Addressable Storage Capacity and requirements.
 - ✓ Capacity of each Logical Volume and requirements.
 - ✓ Capacity of each Application Storage Unit (ASU) and requirements.
- The total Application Storage Unit (ASU) Capacity was filled with random data, using an auditor approved tool, prior to execution of the SPC-1 Tests.

Storage Performance Council
643 Bair Island Road, Suite 103
Redwood City, CA 94062
AuditService@storageperformance.org
650.556.9384

AUDIT CERTIFICATION (CONT.)

IBM Storwize® V3700 (Turbo)
SPC-1 Audit Certification

Page 2

- An appropriate diagram of the Benchmark Configuration (BC)/Tested Storage Configuration (TSC).
- Listings and commands to configure the Benchmark Configuration/Tested Storage Configuration, including customer tunable parameters that were changed from default values.
- SPC-1 Workload Generator commands and parameters used for the audited SPC Test Runs.
- The following Host System requirements were verified by information supplied by IBM Corporation:
 - ✓ The type of Host Systems including the number of processors and main memory.
 - ✓ The presence and version number of the SPC-1 Workload Generator on each Host System.
 - ✓ The TSC boundary within each Host System.
- The execution of each Test, Test Phase, and Test Run was found compliant with all of the requirements and constraints of Clauses 4, 5, and 11 of the SPC-1 Benchmark Specification.
- The Test Results Files and resultant Summary Results Files received from IBM Corporation for each of following were authentic, accurate, and compliant with all of the requirements and constraints of Clauses 4 and 5 of the SPC-1 Benchmark Specification:
 - ✓ Data Persistence Test
 - ✓ Sustainability Test Phase
 - ✓ IOPS Test Phase
 - ✓ Response Time Ramp Test Phase
 - ✓ Repeatability Test
- There were no differences between the Tested Storage Configuration and Priced Storage Configuration.
- The submitted pricing information met all of the requirements and constraints of Clause 8 of the SPC-1 Benchmark Specification.
- The Full Disclosure Report (FDR) met all of the requirements in Clause 9 of the SPC-1 Benchmark Specification.
- This successfully audited SPC measurement is not subject to an SPC Confidential Review.

Audit Notes:

There were no audit notes or exceptions.

Respectfully,

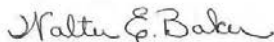

Walter E. Baker
SPC Auditor

Storage Performance Council
643 Bair Island Road, Suite 103
Redwood City, CA 94062
AuditService@storageperformance.org
650.556.9384

LETTER OF GOOD FAITH



Vice President and Disk Storage Business Line Executive

IBM Technology & Systems Group
650 Harry Road, Almaden Research Center
San Jose CA 95120-6099

Phone 1-408-607-0623

April 17, 2014

Mr. Walter E. Baker, SPC Auditor
Gradient Systems, Inc.
643 Bair Island Road, Suite 103
Redwood City, CA 94063

Subject: SPC-1 Letter of Good Faith for the IBM Storwize V3700 with Turbo.

IBM Corporation is the SPC-1 Test Sponsor for the above listed product. To the best of our knowledge and belief, the required SPC-1 benchmark results and materials we have submitted for that product are complete, accurate, and in full compliance with Version 1.14 of the SPC-1 benchmark specification.

Our disclosure of the Benchmark configuration and execution of the benchmark includes all items that, to the best of our knowledge and belief, materially affect the reported results, regardless of whether such items are explicitly required to be disclosed by the SPC-1 benchmark specification.

Sincerely,

A handwritten signature in cursive script, appearing to read "Laura Guio".

Laura Guio
Vice President, Business Line Executive Storage Systems
IBM Systems and Technology Group

EXECUTIVE SUMMARY

Test Sponsor and Contact Information

Test Sponsor and Contact Information	
Test Sponsor Primary Contact	IBM Corporation – http://www.ibm.com Bruce McNutt – bmcnutt@us.ibm.com IBM ARC 650 Harry Road San Jose, CA 95120 Phone: (408) 927-2717 FAX: (408) 927-2050
Test Sponsor Alternate Contact	IBM Corporation – http://www.ibm.com Greg Shephard – shephga@uk.ibm.com IBM Hursley Park Hursley, UK S0212JN Phone: 44 1962 814118
Auditor	Storage Performance Council – http://www.storageperformance.org Walter E. Baker – AuditService@StoragePerformance.org 643 Bair Island Road, Suite 103 Redwood City, CA 94063 Phone: (650) 556-9384 FAX: (650) 556-9385

Revision Information and Key Dates

Revision Information and Key Dates	
SPC-1 Specification revision number	V1.14
SPC-1 Workload Generator revision number	V2.3.0
Date Results were first used publicly	April 18, 2014
Date the FDR was submitted to the SPC	April 18, 2014
Date the Priced Storage Configuration is available for shipment to customers	currently available
Date the TSC completed audit certification	April 18, 2014

Tested Storage Product (TSP) Description

IBM Storwize V3700 is the newest addition to the Storwize family of disk systems. Leveraging proven IBM Storwize V7000 and IBM SAN Volume Controller functions and management tools, Storwize V3700 delivers innovation and new levels of storage efficiency with ease of use in an entry disk system to enable organizations to overcome their storage challenges. The Turbo performance option increases the maximum I/O operations per second (IOPS) and throughput of a Storwize V3700 system

Summary of Results

SPC-1 Reported Data	
Tested Storage Product (TSP) Name: IBM Storwize® V3700 (<i>Turbo</i>)	
Metric	Reported Result
SPC-1 IOPS™	32,505.35
SPC-1 Price-Performance™	\$3.80/SPC-1 IOPS™
Total ASU Capacity	10,307.992 GB
Data Protection Level	Protected 1 (<i>mirroring</i>)
Total Price	\$123,616.18
Currency Used	U.S. Dollars
Target Country for availability, sales and support	USA

SPC-1 IOPS™ represents the maximum I/O Request Throughput at the 100% load point.

SPC-1 Price-Performance™ is the ratio of **Total Price** to SPC-1 IOPS™.

Total ASU (Application Storage Unit) **Capacity** represents the total storage capacity available to be read and written in the course of executing the SPC-1 benchmark.

A **Data Protection Level** of **Protected 1** using *Mirroring* configures two or more identical copies of user data.

***Protected 2:** The single point of failure of any **storage device** in the configuration will not result in permanent loss of access to or integrity of the SPC-1 Data Repository.*

Total Price includes the cost of the Priced Storage Configuration plus three years of hardware maintenance and software support as detailed on page 16.

Currency Used is formal name for the currency used in calculating the **Total Price** and **SPC-1 Price-Performance™**. That currency may be the local currency of the **Target Country** or the currency of a difference country (*non-local currency*).

The **Target Country** is the country in which the Priced Storage Configuration is available for sale and in which the required hardware maintenance and software support is provided either directly from the Test Sponsor or indirectly via a third-party supplier.

Storage Capacities, Relationships, and Utilization

The following four charts and table document the various storage capacities, used in this benchmark, and their relationships, as well as the storage utilization values required to be reported.

The capacity values in each of the following four charts are listed as integer values, for readability, rather than the decimal values listed elsewhere in this document.

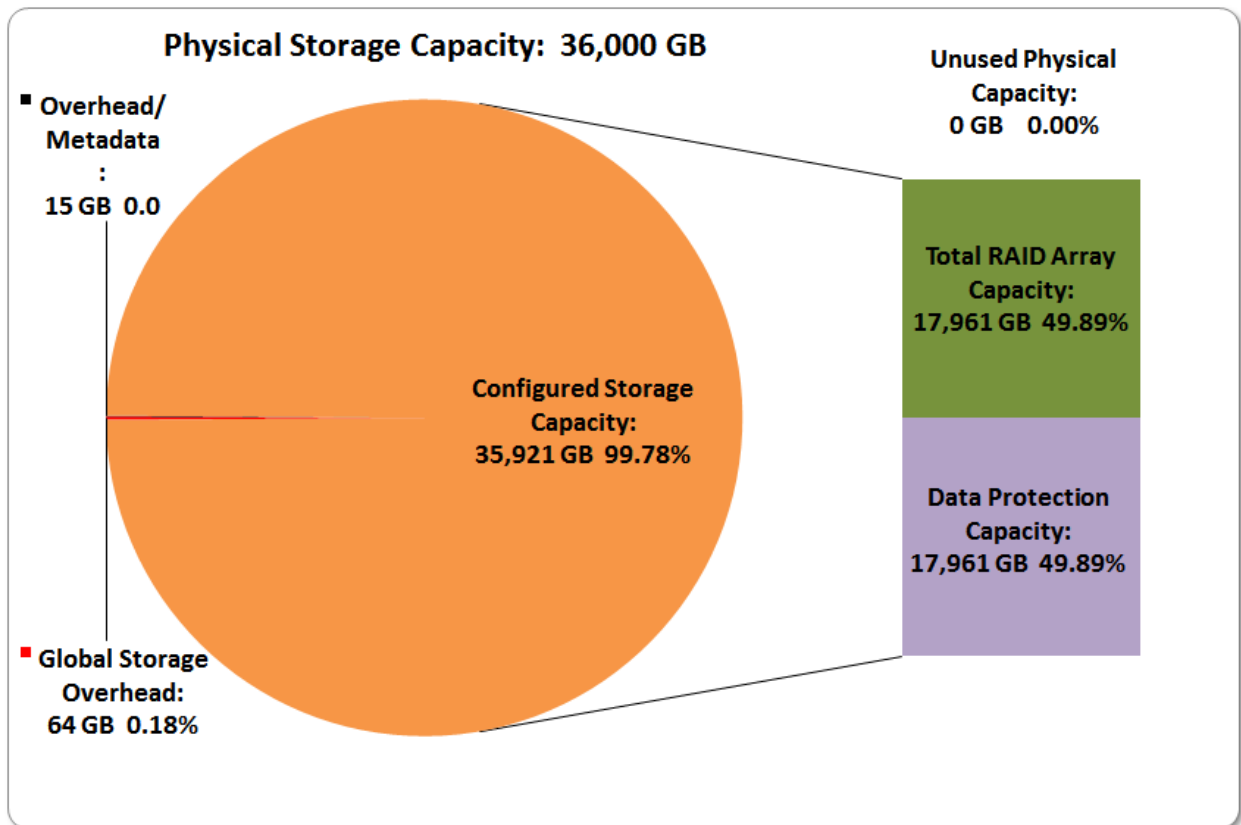

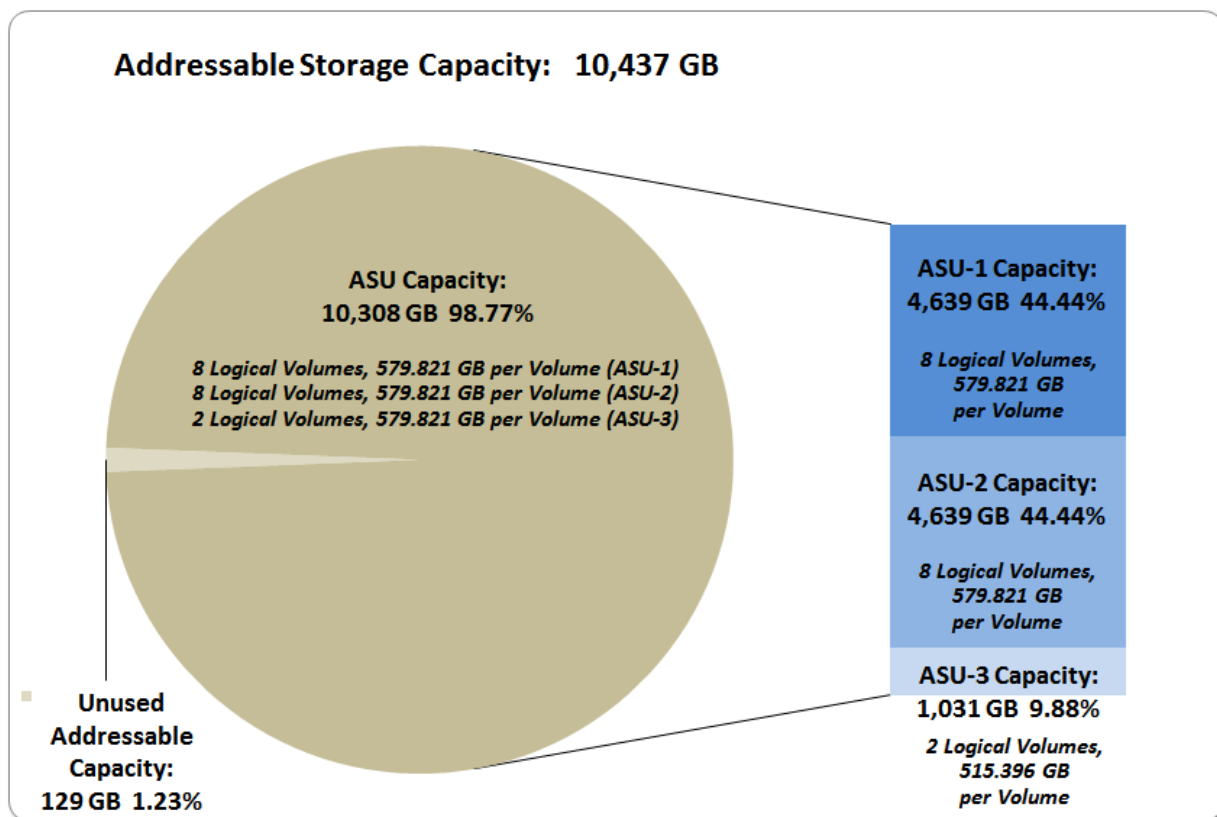
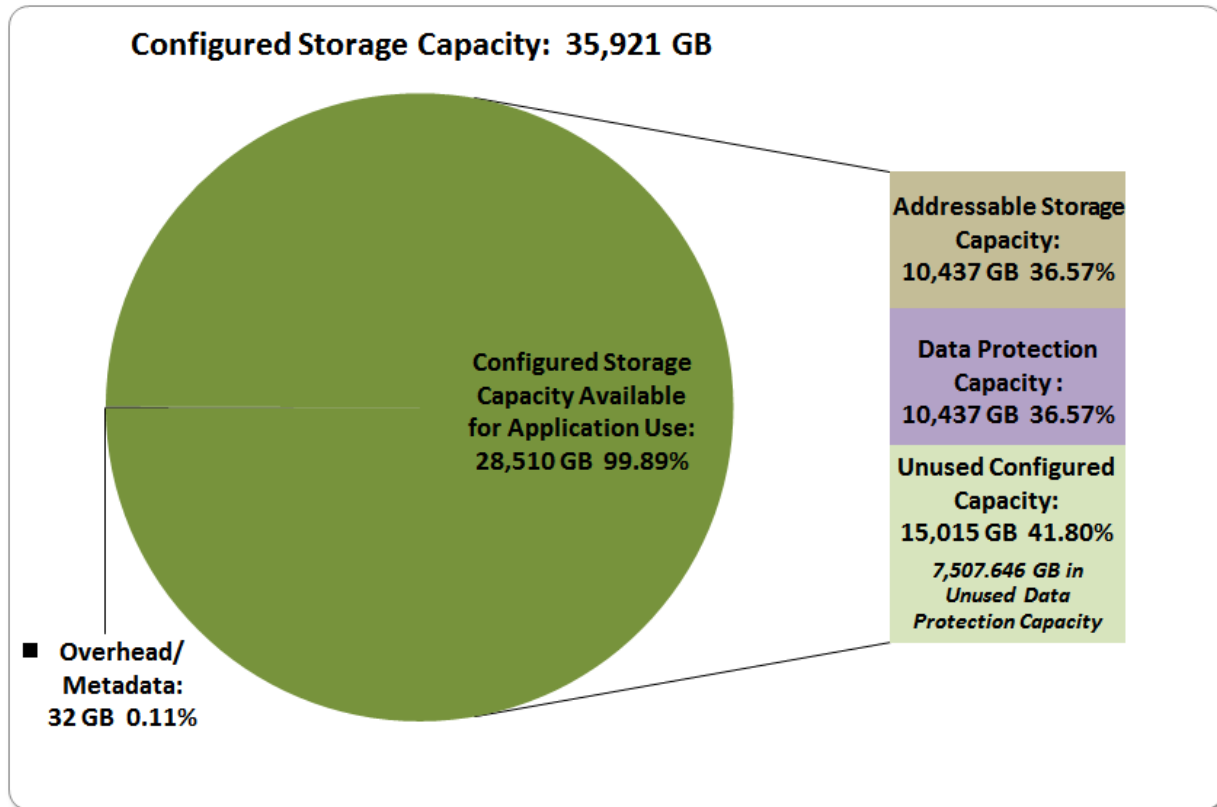

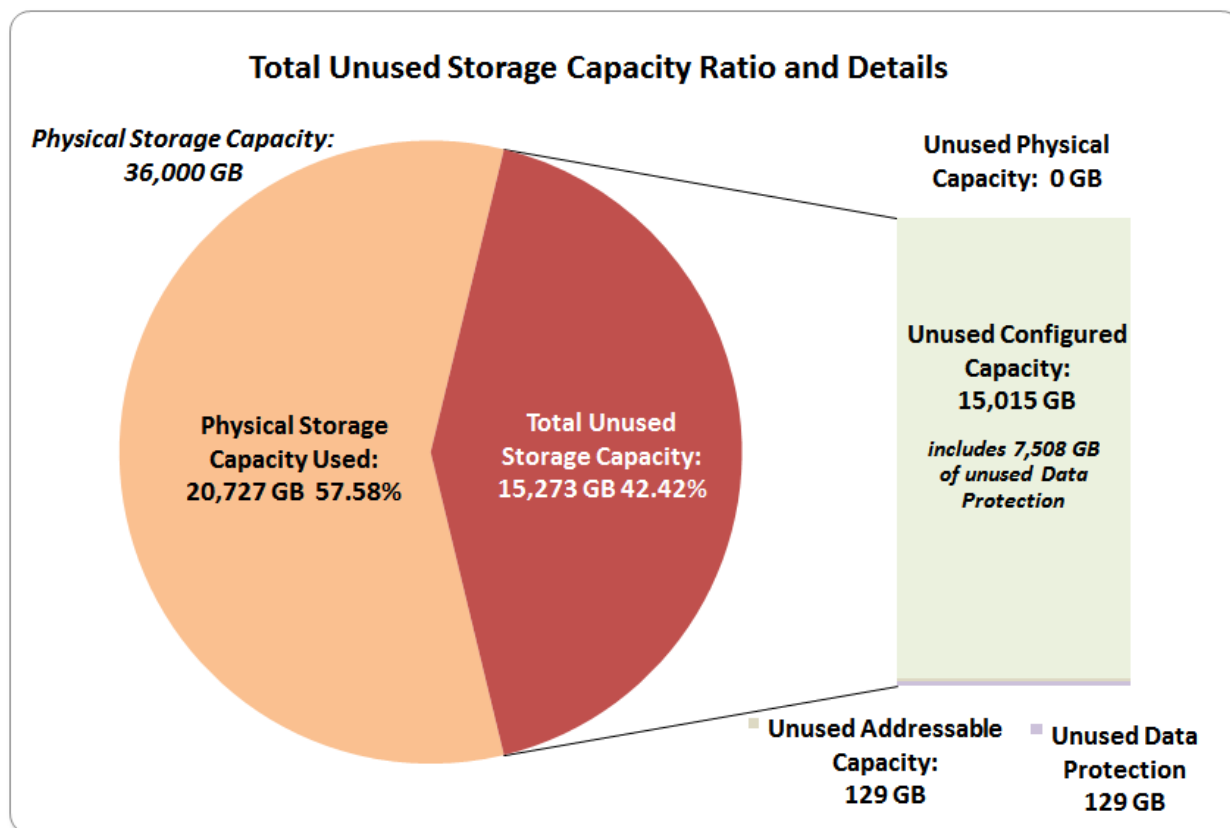

SPC-1 Storage Capacity Utilization	
Application Utilization	28.63%
Protected Application Utilization	57.31%
Unused Storage Ratio	42.42%

Application Utilization: Total ASU Capacity (10,307.922 GB) divided by Physical Storage Capacity (36,000.000 GB).

Protected Application Utilization: (Total ASU Capacity (10,307.922 GB) plus total Data Protection Capacity (17,970.522 GB) minus unused Data Protection Capacity (7,636.495 GB)) divided by Physical Storage Capacity (36,000.000 GB).

Unused Storage Ratio: Total Unused Capacity (15,272.990 GB) divided by Physical Storage Capacity (36,000.000 GB) and may not exceed 45%.

Detailed information for the various storage capacities and utilizations is available on pages 24-25.

Response Time – Throughput Curve

The Response Time-Throughput Curve illustrates the Average Response Time (milliseconds) and I/O Request Throughput at 100%, 95%, 90%, 80%, 50%, and 10% of the workload level used to generate the SPC-1 IOPS™ metric.

The Average Response Time measured at any of the above load points cannot exceed 30 milliseconds or the benchmark measurement is invalid.

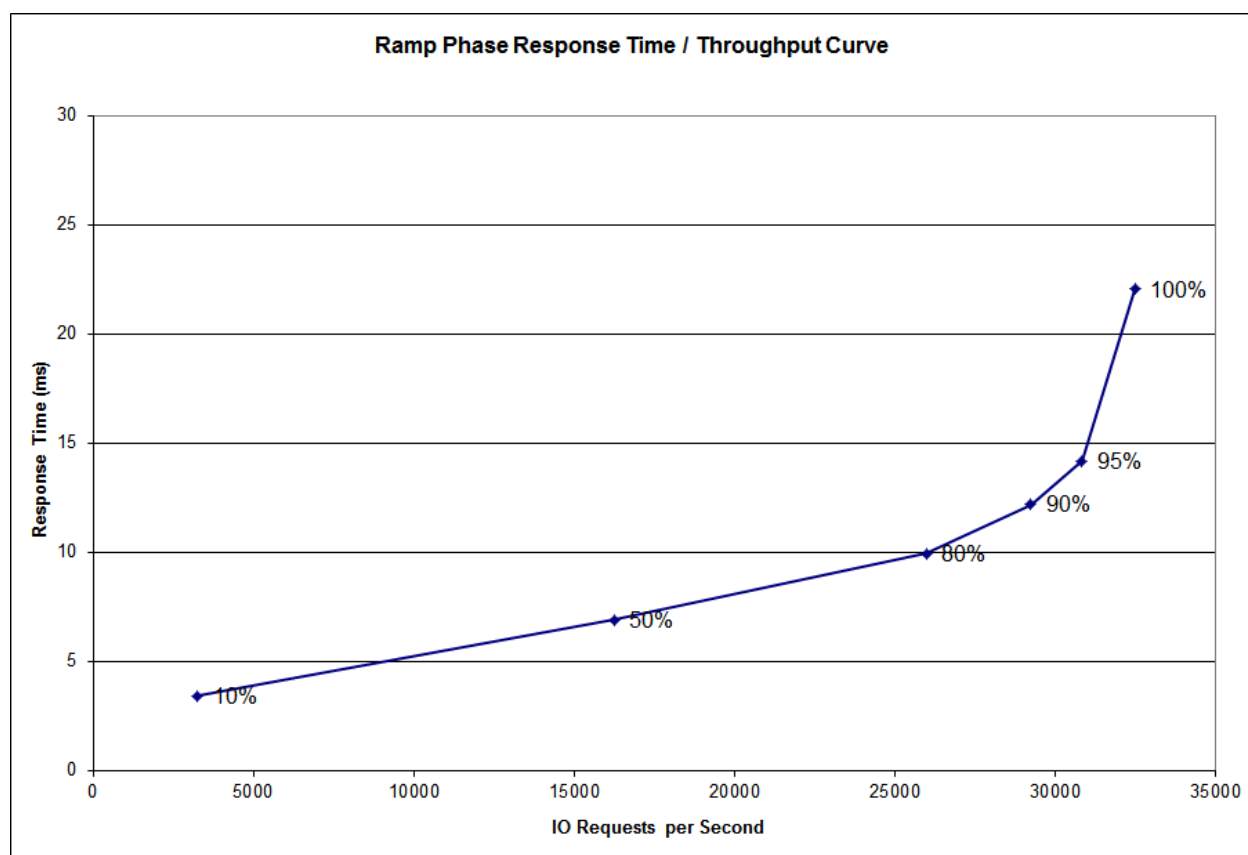

Response Time – Throughput Data

	10% Load	50% Load	80% Load	90% Load	95% Load	100% Load
I/O Request Throughput	3,247.44	16,247.87	25,991.59	29,244.15	30,840.15	32,505.35
Average Response Time (ms):						
All ASUs	3.40	6.90	9.93	12.19	14.19	22.04
ASU-1	3.88	7.09	10.12	12.22	13.98	19.91
ASU-2	3.48	7.43	11.05	13.68	15.78	22.41
ASU-3	2.37	6.28	9.03	11.49	13.95	26.41
Reads	5.31	8.15	11.68	13.85	15.40	18.49
Writes	2.17	6.09	8.79	11.12	13.40	24.36

Priced Storage Configuration Pricing

Description	Qty	Unit Price	extended	% discount	discounted price
V3700 base enclosure (2072-24C)	1	\$8,799.00	\$8,799.00	28	\$6,335.28
V3700 expansion enclosure (2072-24E)	4	\$3,999.00	\$15,996.00	28	\$11,517.12
Turbo performance (ACFA)	1	\$6,850.00	\$6,850.00	28	\$4,932.00
4 GB to 8 GB Cache Upgrade (ACHB)	2	\$2,499.00	\$4,998.00	28	\$3,598.56
15K RPM 300 GB drives (ACLB)	120	\$669.00	\$80,280.00	28	\$57,801.60
4 x 8 Gbps FC card (ACHK)	2	\$1,099.00	\$2,198.00	28	\$1,582.56
Pair of SFPs (ACHS)	2	\$279.00	\$558.00	28	\$401.76
SAS 1.5 m cable (ACTB)	8	\$129.00	\$1,032.00	28	\$743.04
Short wave 5m fibre channel cable (ACSK)	8	\$129.00	\$1,032.00	28	\$743.04
Short wave 25 m fibre channel cable (ACSL)	8	\$189.00	\$1,512.00	28	\$1,088.64
4 x dual port qllogic HBA for xSeries (7915-3579)	4	\$1,849.00	\$7,396.00	0	\$7,396.00
SAN48-5 FC switch (2498-F48 w/24 ports active, 16 SFP)	1	\$24,614.00	\$24,614.00	20	\$19,691.20
HW/SW Total					\$115,830.80
WSU for Hardware					
Storwize V3700 Controller Enclosure	1	\$1,692.00	\$1,692.00	20	\$1,353.60
Storwize V3700 Expansion Enclosure	4	\$1,200.00	\$4,800.00	20	\$3,840.00
Warranty for switch	1	\$3,239.72	\$3,239.72	20	\$2,591.78
Total Warranty/Maintenance					\$7,785.38
Grand Total					\$123,616.18

The above pricing includes hardware maintenance and software support for three years, 7 days per week, 24 hours per day. The hardware maintenance and software support provides the following:

- Acknowledgement of new and existing problems with four (4) hours.
- Onsite presence of a qualified maintenance engineer or provision of a customer replaceable part within four (4) hours of the above acknowledgement for any hardware failure that results in an inoperative Price Storage Configuration that can be remedied by the repair or replacement of a Priced Storage Configuration component.

Differences between the Tested Storage Configuration (TSC) and Priced Storage Configuration

There were no differences between the TSC and the Priced Storage Configuration.

Priced Storage Configuration Diagram

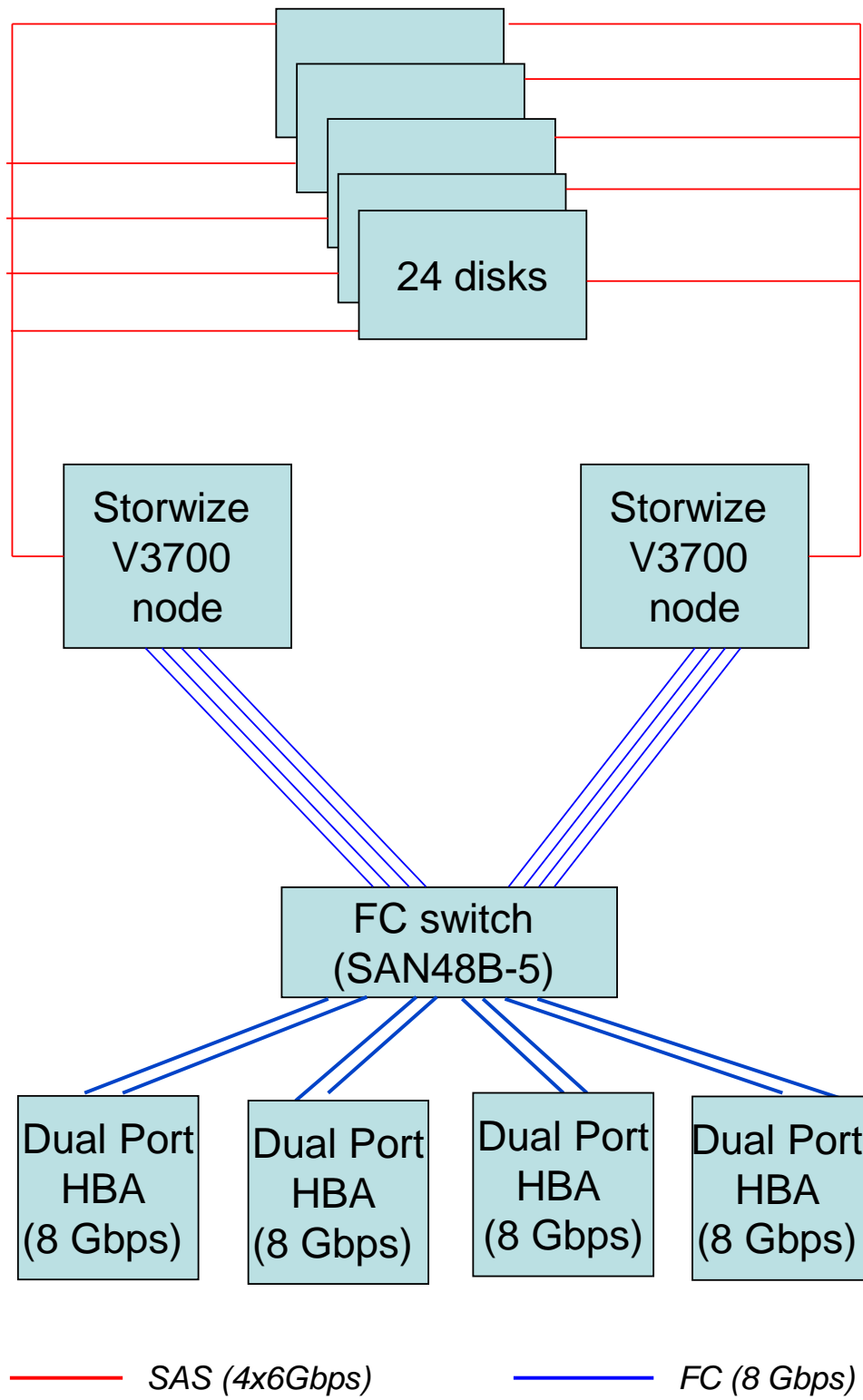

Priced Storage Configuration Components

Priced Storage Configuration
4 – Qlogic dual-port 8 Gbps FC HBAs for xSeries
1 – SAN48-5 FC switch w/24 ports active, 16 SFPs
IBM Storwize® V3700 (Turbo) V3700 base enclosure w/24 slots 2 – Storwize V3700 Cannister Nodes, each with 8 GB memory/cache (<i>16 GB total</i>) 1 – 4-port 8 Gbps FC card (<i>2 total</i>) 8 – 8 Gbps FC front-end connections 1 – 4x6 Gbps SAS connection (<i>4 PHYs</i>) (<i>2 connections total, 8 PHYs total and used</i>)
4 – V3700 expansion enclosures
120 – 300 GB 15K RPM disk drives (<i>24 disk drives per enclosure, base and expansion</i>)

In each of the following sections of this document, the appropriate Full Disclosure Report requirement, from the SPC-1 benchmark specification, is stated in italics followed by the information to fulfill the stated requirement.

CONFIGURATION INFORMATION

Benchmark Configuration (BC)/Tested Storage Configuration (TSC) Diagram

Clause 9.4.3.4.1

A one page Benchmark Configuration (BC)/Tested Storage Configuration (TSC) diagram shall be included in the FDR...

The Benchmark Configuration (BC)/Tested Storage Configuration (TSC) is illustrated on page [20 \(Benchmark Configuration/Tested Storage Configuration Diagram\)](#).

Storage Network Configuration

Clause 9.4.3.4.1

...

- 5. If the TSC contains network storage, the diagram will include the network configuration. If a single diagram is not sufficient to illustrate both the Benchmark Configuration and network configuration in sufficient detail, the Benchmark Configuration diagram will include a high-level network illustration as shown in Figure 9-8. In that case, a separate, detailed network configuration diagram will also be included as described in Clause 9.4.3.4.2.*

Clause 9.4.3.4.2

If a storage network was configured as a part of the Tested Storage Configuration and the Benchmark Configuration diagram described in Clause 9.4.3.4.1 contains a high-level illustration of the network configuration, the Executive Summary will contain a one page topology diagram of the storage network as illustrated in Figure 9-9.

The storage network portion of the Benchmark Configuration(BC)/Tested Storage Configuration (TSC) is illustrated on page [20 \(Benchmark Configuration/Tested Storage Configuration Diagram\)](#).

Host System(s) and Tested Storage Configuration (TSC) Table of Components

Clause 9.4.3.4.3

The FDR will contain a table that lists the major components of each Host System and the Tested Storage Configuration (TSC).

The Host System(s) and TSC table of components may be found on page [21 \(Host System and Tested Storage Configuration Components\)](#).

Benchmark Configuration/Tested Storage Configuration Diagram

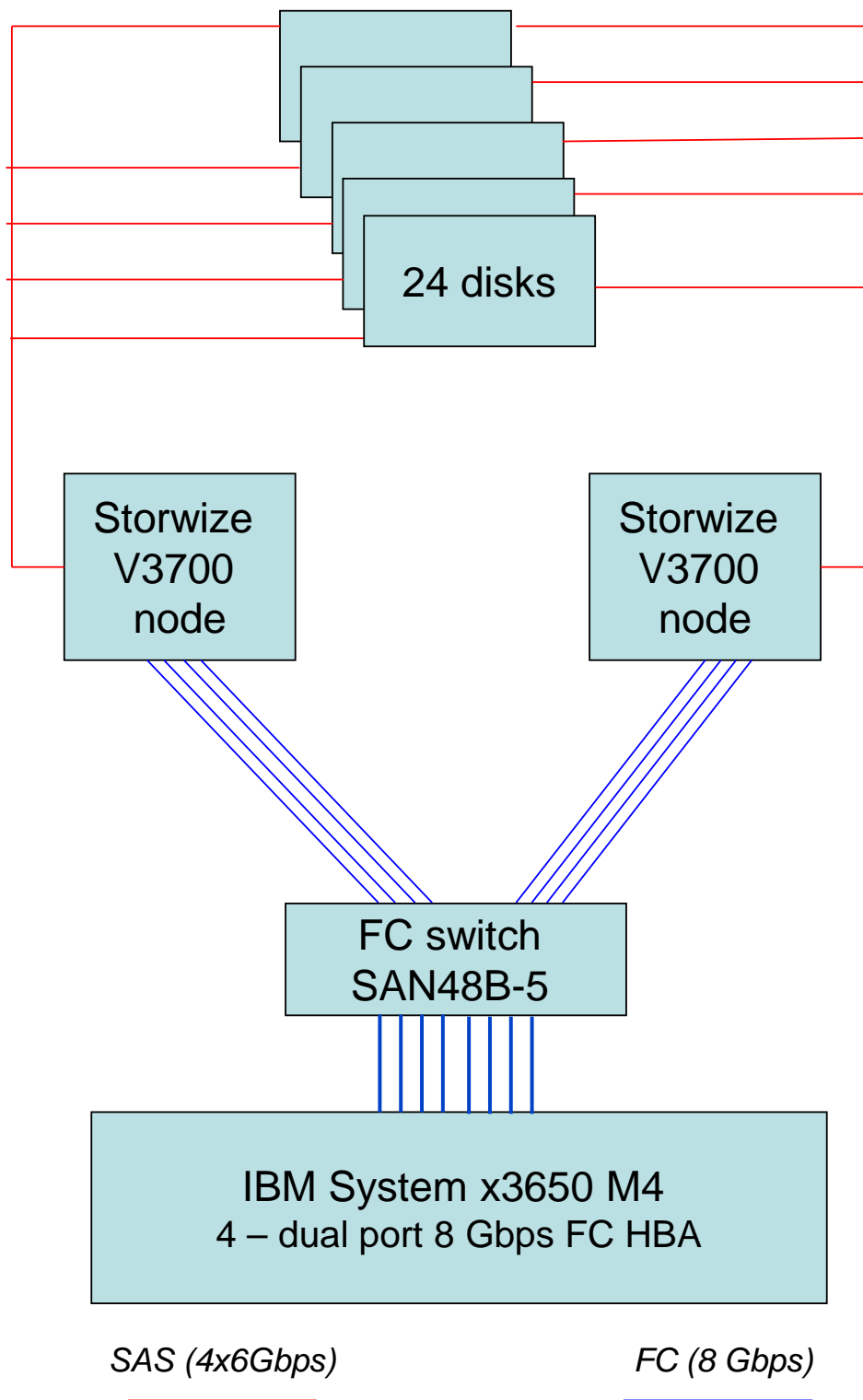

Host System and Tested Storage Configuration Components

Host System
<p>1 – IBM System x3650 M4, with:</p> <ul style="list-style-type: none"> 2 – Intel® Xeon® 2.0 GHz E5-2650 processors with 8 cores per processor, 20 MiB shared cache 32 GiB main memory Windows Server 2008 R2 PCIe
Tested Storage Configuration (TSC) Components
4 – Qlogic dual-port 8 Gbps FC HBAs for xSeries
1 – SAN48-5 FC switch w/24 ports active, 16 SFPs
<p>IBM Storwize® V3700 (Turbo)</p> <p>V3700 base enclosure w/24 slots</p> <ul style="list-style-type: none"> 2 – Storwize V3700 Cannister Nodes, each with 8 GB memory/cache (<i>16 GB total</i>) 1 – 4-port 8 Gbps FC card (<i>2 total</i>) 8 – 8 Gbps FC front-end connections 1 – 4x6 Gbps SAS connection (<i>4 PHYs</i>) (<i>2 connections total, 8 PHYs total and used</i>)
4 – V3700 expansion enclosures
120 – 300 GB 15K RPM disk drives (<i>24 disk drives per enclosure, base and expansion</i>)

Customer Tunable Parameters and Options

Clause 9.4.3.5.1

All Benchmark Configuration (BC) components with customer tunable parameter and options that have been altered from their default values must be listed in the FDR. The FDR entry for each of those components must include both the name of the component and the altered value of the parameter or option. If the parameter name is not self-explanatory to a knowledgeable practitioner, a brief description of the parameter's use must also be included in the FDR entry.

[Appendix B: Customer Tunable Parameters and Options](#) on page [65](#) contains the customer tunable parameters and options that have been altered from their default values for this benchmark.

Tested Storage Configuration (TSC) Description

Clause 9.4.3.5.2

The FDR must include sufficient information to recreate the logical representation of the TSC. In addition to customer tunable parameters and options (Clause 4.2.4.5.3), that information must include, at a minimum:

- A diagram and/or description of the following:
 - All physical components that comprise the TSC. Those components are also illustrated in the BC Configuration Diagram in Clause 9.2.4.4.1 and/or the Storage Network Configuration Diagram in Clause 9.2.4.4.2.
 - The logical representation of the TSC, configured from the above components that will be presented to the Workload Generator.
- Listings of scripts used to create the logical representation of the TSC.
- If scripts were not used, a description of the process used with sufficient detail to recreate the logical representation of the TSC.

[Appendix C: Tested Storage Configuration \(TSC\) Creation](#) on page [66](#) contains the detailed information that describes how to create and configure the logical TSC.

SPC-1 Workload Generator Storage Configuration

Clause 9.4.3.5.3

The FDR must include all SPC-1 Workload Generator storage configuration commands and parameters.

The SPC-1 Workload Generator storage configuration commands and parameters for this measurement appear in [Appendix D: SPC-1 Workload Generator Storage Commands and Parameters](#) on page [71](#).

ASU Pre-Fill

Clause 5.3.3

Each of the three SPC-1 ASUs (ASU-1, ASU-2 and ASU-3) is required to be completely filled with specified content prior to the execution of audited SPC-1 Tests. The content is required to consist of random data pattern such as that produced by an SPC recommended tool.

The configuration file used to complete the required ASU pre-fill appears in [Appendix D: SPC-1 Workload Generator Storage Commands and Parameters](#) on page [71](#).

SPC-1 DATA REPOSITORY

This portion of the Full Disclosure Report presents the detailed information that fully documents the various SPC-1 storage capacities and mappings used in the Tested Storage Configuration. [SPC-1 Data Repository Definitions](#) on page [61](#) contains definitions of terms specific to the SPC-1 Data Repository.

Storage Capacities and Relationships

Clause 9.4.3.6.1

Two tables and four charts documenting the storage capacities and relationships of the SPC-1 Storage Hierarchy (Clause 2.1) shall be included in the FDR. ... The capacity value in each chart may be listed as an integer value, for readability, rather than the decimal value listed in the table below.

SPC-1 Storage Capacities

The Physical Storage Capacity consisted of 36,000.000 GB distributed over 120 disk drives (HDDs), each with a formatted capacity of 300.000 GB.. There was 0.000 GB (0.00%) of Unused Storage within the Physical Storage Capacity. Global Storage Overhead consisted of 64.009 GB (0.18%) of the Physical Storage Capacity. There was 15,015.292 GB (41.80%) of Unused Storage within the Configured Storage Capacity. The Total ASU Capacity utilized 98.77% of the Addressable Storage Capacity resulting in 128.849 GB (1.23%) of Unused Storage within the Addressable Storage Capacity. The Data Protection (*Mirroring*) capacity was 17,960.522 GB of which 10,307.922 GB was utilized. The total Unused Storage capacity was 15,272.990 GB.

Note: The configured Storage Devices may include additional storage capacity reserved for system overhead, which is not accessible for application use. That storage capacity may not be included in the value presented for Physical Storage Capacity.

SPC-1 Storage Capacities		
Storage Hierarchy Component	Units	Capacity
Total ASU Capacity	Gigabytes (GB)	10,307.922
Addressable Storage Capacity	Gigabytes (GB)	10,436.771
Configured Storage Capacity	Gigabytes (GB)	35,921.045
Physical Storage Capacity	Gigabytes (GB)	36,000.000
Data Protection (<i>Mirroring</i>)	Gigabytes (GB)	17,960.522
Required Storage (<i>metadata/overhead</i>)	Gigabytes (GB)	47.159
Global Storage Overhead	Gigabytes (GB)	64.009
Total Unused Storage	Gigabytes (GB)	15,272.990

SPC-1 Storage Hierarchy Ratios

	Addressable Storage Capacity	Configured Storage Capacity	Physical Storage Capacity
Total ASU Capacity	98.77%	28.70%	28.63%
Required for Data Protection (<i>Mirroring</i>)		50.00%	49.89%
Addressable Storage Capacity		29.05%	28.99%
Required Storage (<i>spares, overhead</i>)		0.13%	0.13%
Configured Storage Capacity			99.78%
Global Storage Overhead			0.18%
Unused Storage:			
Addressable	1.23%		
Configured		41.80%	
Physical			0.00%

SPC-1 Storage Capacity Charts

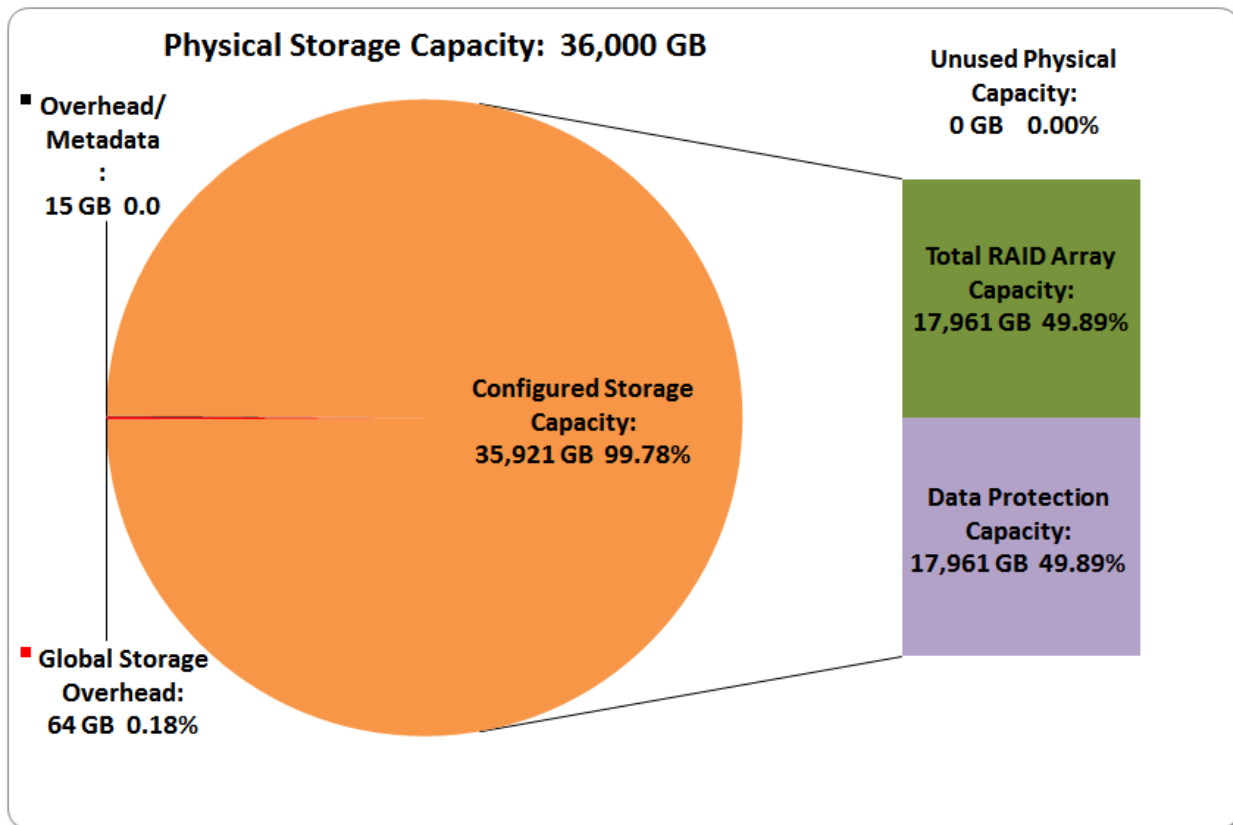

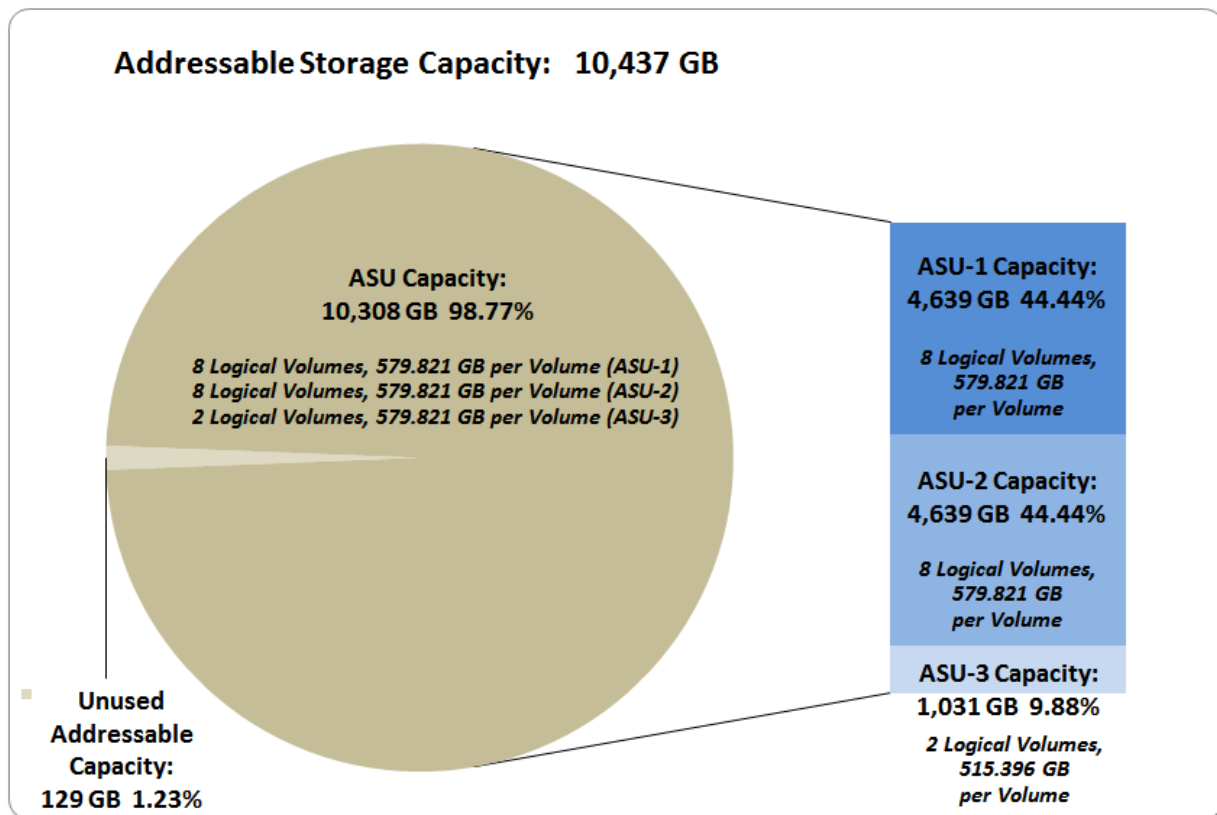
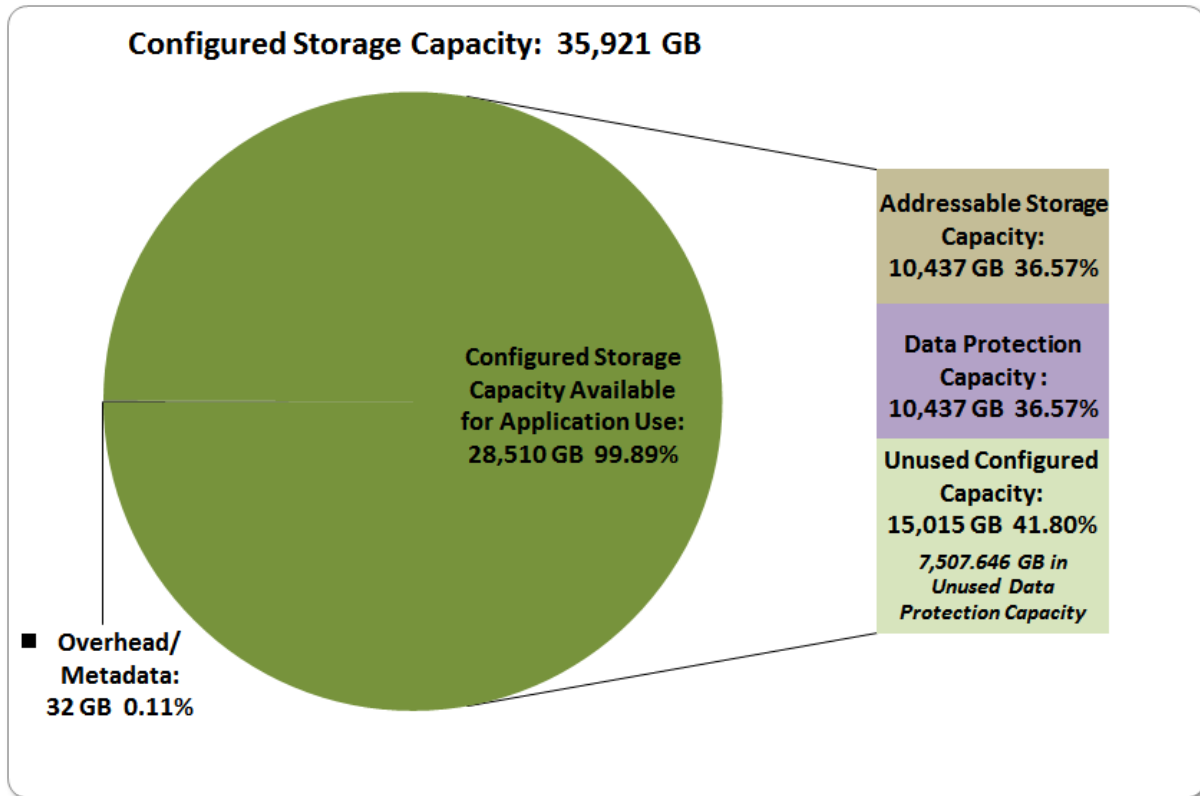

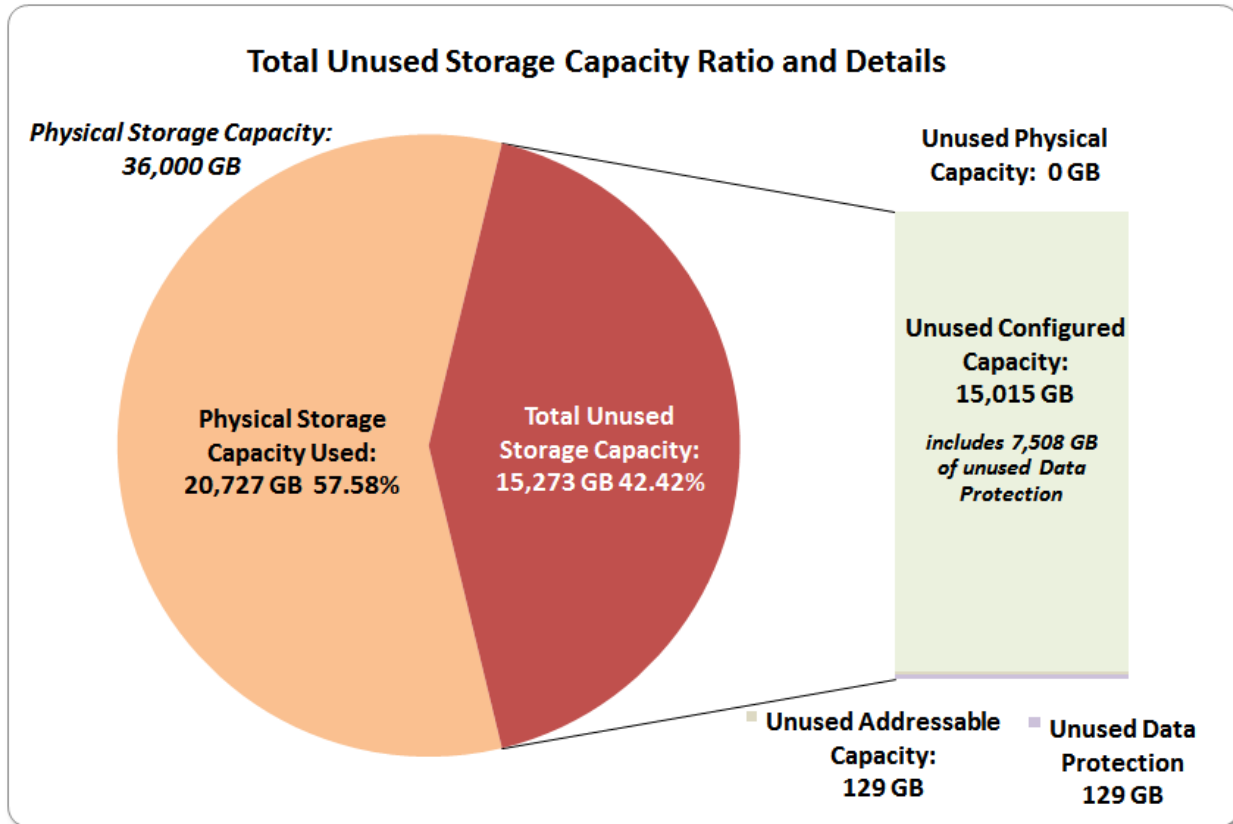

Storage Capacity Utilization

Clause 9.4.3.6.2

The FDR will include a table illustrating the storage capacity utilization values defined for Application Utilization (Clause 2.8.1), Protected Application Utilization (Clause 2.8.2), and Unused Storage Ratio (Clause 2.8.3).

Clause 2.8.1

Application Utilization is defined as Total ASU Capacity divided by Physical Storage Capacity.

Clause 2.8.2

Protected Application Utilization is defined as (Total ASU Capacity plus total Data Protection Capacity minus unused Data Protection Capacity) divided by Physical Storage Capacity.

Clause 2.8.3

Unused Storage Ratio is defined as Total Unused Capacity divided by Physical Storage Capacity and may not exceed 45%.

SPC-1 Storage Capacity Utilization	
Application Utilization	28.63%
Protected Application Utilization	56.31%
Unused Storage Ratio	42.42%

Logical Volume Capacity and ASU Mapping

Clause 9.4.3.6.3

A table illustrating the capacity of each ASU and the mapping of Logical Volumes to ASUs shall be provided in the FDR. ... Logical Volumes shall be sequenced in the table from top to bottom per its position in the contiguous address space of each ASU. The capacity of each Logical Volume shall be stated. ... In conjunction with this table, the Test Sponsor shall provide a complete description of the type of data protection (see Clause 2.4.5) used on each Logical Volume.

Logical Volume Capacity and Mapping		
ASU-1 (4,638.565 GB)	ASU-2 (4,638.565 GB)	ASU-3 (1,030.792 GB)
8 Logical Volumes GB per Logical Volume (GB used per Logical Volume)	8 Logical Volumes GB per Logical Volume (GB used per Logical Volume)	2 Logical Volumes GB per Logical Volume (GB used per Logical Volume)

The Data Protection Level used for all Logical Volumes was [Protected 1](#) using *Mirroring* as described on page [11](#). See “ASU Configuration” in the [IOPS Test Results File](#) for more detailed configuration information.

SPC-1 BENCHMARK EXECUTION RESULTS

This portion of the Full Disclosure Report documents the results of the various SPC-1 Tests, Test Phases, and Test Runs. An [SPC-1 glossary](#) on page 61 contains definitions of terms specific to the SPC-1 Tests, Test Phases, and Test Runs.

Clause 5.4.3

The Tests must be executed in the following sequence: Primary Metrics, Repeatability, and Data Persistence. That required sequence must be uninterrupted from the start of Primary Metrics to the completion of Persistence Test Run 1. Uninterrupted means the Benchmark Configuration shall not be power cycled, restarted, disturbed, altered, or adjusted during the above measurement sequence. If the required sequence is interrupted other than for the Host System/TSC power cycle between the two Persistence Test Runs, the measurement is invalid.

SPC-1 Tests, Test Phases, and Test Runs

The SPC-1 benchmark consists of the following Tests, Test Phases, and Test Runs:

- **Primary Metrics Test**
 - Sustainability Test Phase and Test Run
 - IOPS Test Phase and Test Run
 - Response Time Ramp Test Phase
 - 95% of IOPS Test Run
 - 90% of IOPS Test Run
 - 80% of IOPS Test Run
 - 50% of IOPS Test Run
 - 10% of IOPS Test Run (LRT)
- **Repeatability Test**
 - Repeatability Test Phase 1
 - 10% of IOPS Test Run (LRT)
 - IOPS Test Run
 - Repeatability Test Phase 2
 - 10% of IOPS Test Run (LRT)
 - IOPS Test Run
- **Data Persistence Test**
 - Data Persistence Test Run 1
 - Data Persistence Test Run 2

Each Test is an atomic unit that must be executed from start to finish before any other Test, Test Phase, or Test Run may be executed.

The results from each Test, Test Phase, and Test Run are listed below along with a more detailed explanation of each component.

“Ramp-Up” Test Runs

Clause 5.3.13

In order to warm-up caches or perform the initial ASU data migration in a multi-tier configuration, a Test Sponsor may perform a series of “Ramp-Up” Test Runs as a substitute for an initial, gradual Ramp-Up.

Clause 5.3.13.3

The “Ramp-Up” Test Runs will immediately precede the Primary Metrics Test as part of the uninterrupted SPC-1 measurement sequence.

Clause 9.4.3.7.1

If a series of “Ramp-Up” Test Runs were included in the SPC-1 measurement sequence, the FDR shall report the duration (ramp-up and measurement interval), BSU level, SPC-1 IOPS and average response time for each “Ramp-Up” Test Run in an appropriate table.

There were no “Ramp-Up” Test Runs executed.

Primary Metrics Test – Sustainability Test Phase

Clause 5.4.4.1.1

The Sustainability Test Phase has exactly one Test Run and shall demonstrate the maximum sustainable I/O Request Throughput within at least a continuous eight (8) hour Measurement Interval. This Test Phase also serves to insure that the TSC has reached Steady State prior to reporting the final maximum I/O Request Throughput result (SPC-1 IOPS™).

Clause 5.4.4.1.2

The computed I/O Request Throughput of the Sustainability Test must be within 5% of the reported SPC-1 IOPS™ result.

Clause 5.4.4.1.4

The Average Response Time, as defined in Clause 5.1.1, will be computed and reported for the Sustainability Test Run and cannot exceed 30 milliseconds. If the Average Response time exceeds that 30-milliseconds constraint, the measurement is invalid.

Clause 9.4.3.7.2

For the Sustainability Test Phase the FDR shall contain:

- 1. A Data Rate Distribution graph and data table.*
- 2. I/O Request Throughput Distribution graph and data table.*
- 3. A Response Time Frequency Distribution graph and table.*
- 4. An Average Response Time Distribution graph and table.*
- 5. The human readable Test Run Results File produced by the Workload Generator (may be included in an appendix).*
- 6. A listing or screen image of all input parameters supplied to the Workload Generator (may be included in an appendix).*
- 7. The Measured Intensity Multiplier for each I/O stream.*
- 8. The variability of the Measured Intensity Multiplier, as defined in Clause 5.3.13.3.*

SPC-1 Workload Generator Input Parameters

The SPC-1 Workload Generator input parameters for the Sustainability, IOPS, Response Time Ramp, Repeatability, and Persistence Test Runs are documented in [Appendix E: SPC-1 Workload Generator Input Parameters](#) on Page 73.

Sustainability Test Results File

A link to the test results file generated from the Sustainability Test Run is listed below.

[Sustainability Test Results File](#)

Sustainability – Data Rate Distribution Data (MB/second)

The Sustainability Data Rate table of data is not embedded in this document due to its size. The table is available via the following URL:

[Sustainability Data Rate Table](#)

Sustainability – Data Rate Distribution Graph

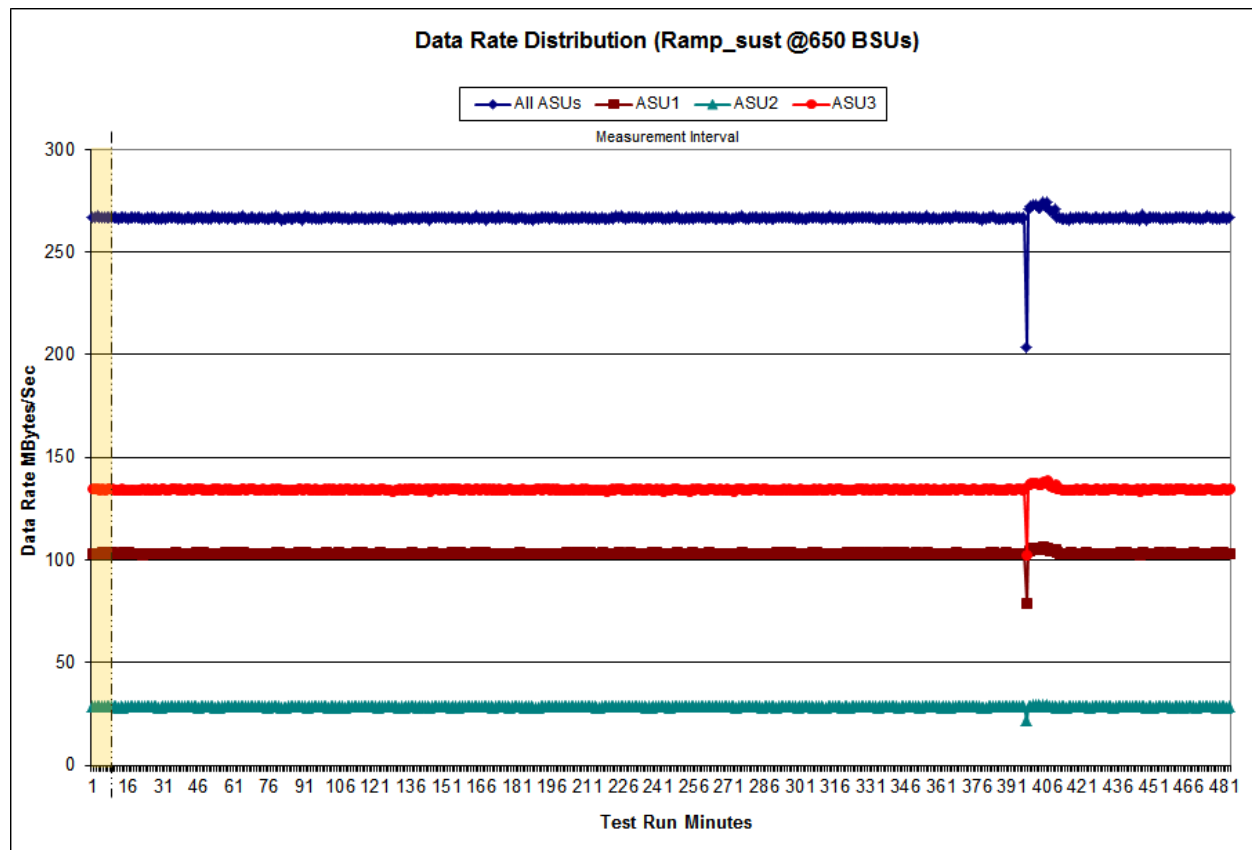

Sustainability – I/O Request Throughput Distribution Data

The Sustainability I/O Request Throughput table of data is not embedded in this document due to its size. The table is available via the following URL:

[Sustainability I/O Request Throughput Table](#)

Sustainability – I/O Request Throughput Distribution Graph

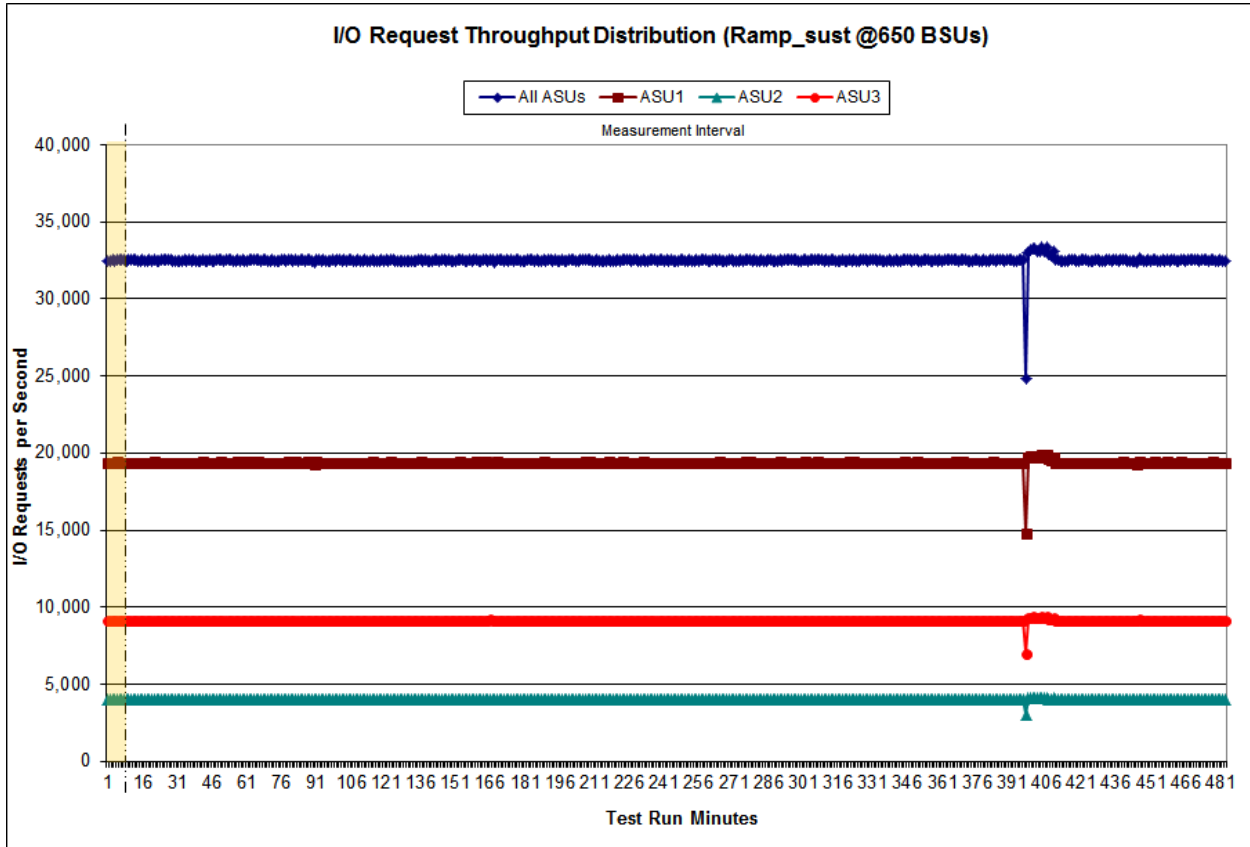

Sustainability – Average Response Time (ms) Distribution Data

The Sustainability Average Response Time table of data is not embedded in this document due to its size. The table is available via the following URL:

[Sustainability Average Response Time Table](#)

Sustainability – Average Response Time (ms) Distribution Graph

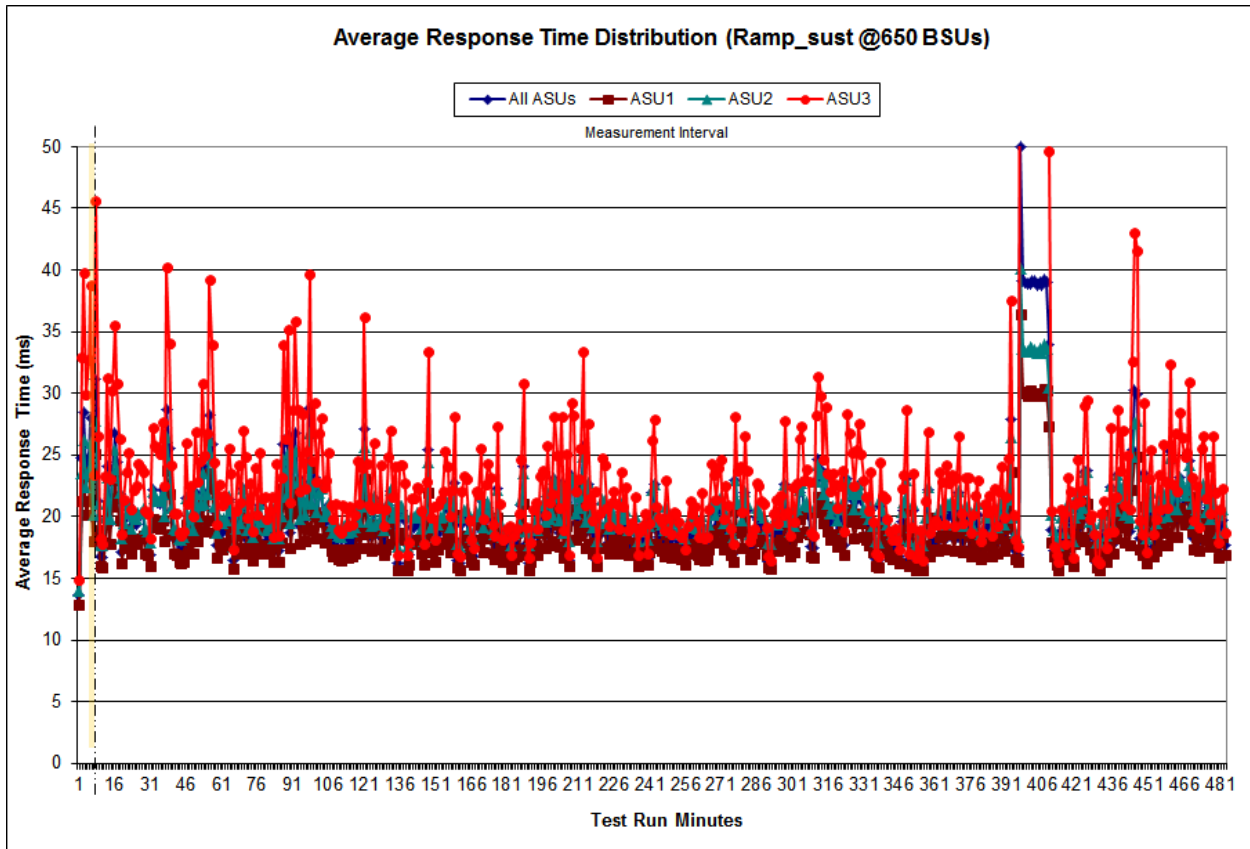

Sustainability – Response Time Frequency Distribution Data

Response Time (ms)	0-0.25	>0.25-0.5	>0.5-0.75	>0.75-1.0	>1.0-1.25	>1.25-1.5	>1.5-1.75	>1.75-2.0
Read	36,778	116,225	234,997	322,255	303,590	284,015	285,877	287,767
Write	-	-	-	-	-	-	-	3
All ASUs	36,778	116,225	234,997	322,255	303,590	284,015	285,877	287,770
ASU1	33,929	106,187	214,714	294,974	277,316	258,254	258,815	259,394
ASU2	2,849	10,038	20,283	27,281	26,274	25,761	27,062	28,374
ASU3	-	-	-	-	-	-	-	2
Response Time (ms)	>2.0-2.5	>2.5-3.0	>3.0-3.5	>3.5-4.0	>4.0-4.5	>4.5-5.0	>5.0-6.0	>6.0-7.0
Read	594,871	675,269	840,449	1,133,271	1,648,812	2,477,086	8,750,005	15,235,776
Write	10	102	240	483	608	719	1,236	2,294
All ASUs	594,881	675,371	840,689	1,133,754	1,649,420	2,477,805	8,751,241	15,238,070
ASU1	530,062	589,137	716,717	948,695	1,363,586	2,048,287	7,347,561	13,099,495
ASU2	64,817	86,193	123,871	184,857	285,604	429,238	1,403,175	2,137,696
ASU3	2	41	101	202	230	280	505	879
Response Time (ms)	>7.0-8.0	>8.0-9.0	>9.0-10.0	>10.0-15.0	>15.0-20.0	>20.0-25.0	>25.0-30.0	>30.0
Read	20,261,562	23,171,257	25,210,362	111,326,170	40,808,619	54,183,054	22,987,731	38,004,435
Write	20,681	481,593	4,622,122	251,088,636	103,613,658	72,646,342	47,638,716	86,735,155
All ASUs	20,282,243	23,652,850	29,832,484	362,414,806	144,422,277	126,829,396	70,626,447	124,739,590
ASU1	17,667,323	20,550,616	24,392,014	213,265,205	80,744,452	74,980,246	36,726,421	61,220,083
ASU2	2,606,990	2,916,454	3,619,813	41,976,095	16,927,161	16,318,845	8,519,779	17,374,306
ASU3	7,930	185,780	1,820,657	107,173,506	46,750,664	35,530,305	25,380,247	46,145,201

Sustainability – Response Time Frequency Distribution Graph

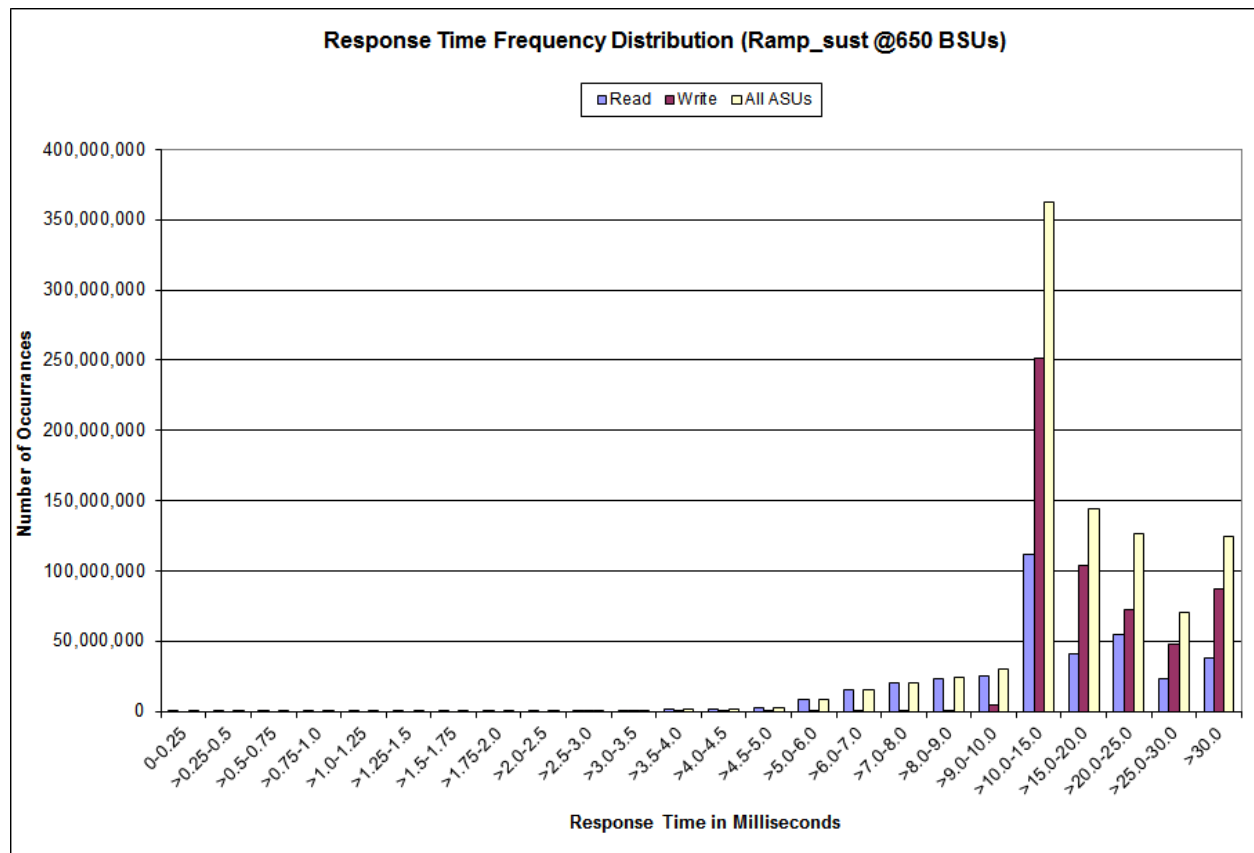

Sustainability – Measured Intensity Multiplier and Coefficient of Variation

Clause 3.4.3

IM – Intensity Multiplier: The ratio of I/Os for each I/O stream relative to the total I/Os for all I/O streams (ASU1-1 – ASU3-1) as required by the benchmark specification.

Clauses 5.1.10 and 5.3.15.2

MIM – Measured Intensity Multiplier: The Measured Intensity Multiplier represents the ratio of measured I/Os for each I/O stream relative to the total I/Os measured for all I/O streams (ASU1-1 – ASU3-1). This value may differ from the corresponding Expected Intensity Multiplier by no more than 5%.

Clause 5.3.15.3

COV – Coefficient of Variation: This measure of variation for the Measured Intensity Multiplier cannot exceed 0.2.

	ASU1-1	ASU1-2	ASU1-3	ASU1-4	ASU2-1	ASU2-2	ASU2-3	ASU3-1
IM	0.0350	0.2810	0.0700	0.2100	0.0180	0.0700	0.0350	0.2810
MIM	0.0350	0.2810	0.0700	0.2100	0.0180	0.0700	0.0350	0.2810
COV	0.004	0.001	0.003	0.001	0.005	0.003	0.004	0.001

Primary Metrics Test – IOPS Test Phase

Clause 5.4.4.2

The IOPS Test Phase consists of one Test Run at the 100% load point with a Measurement Interval of ten (10) minutes. The IOPS Test Phase immediately follows the Sustainability Test Phase without any interruption or manual intervention.

The IOPS Test Run generates the SPC-1 IOPS™ primary metric, which is computed as the I/O Request Throughput for the Measurement Interval of the IOPS Test Run.

The Average Response Time is computed for the IOPS Test Run and cannot exceed 30 milliseconds. If the Average Response Time exceeds the 30 millisecond constraint, the measurement is invalid.

Clause 9.4.3.7.3

For the IOPS Test Phase the FDR shall contain:

- 1. I/O Request Throughput Distribution (data and graph).*
- 2. A Response Time Frequency Distribution.*
- 3. An Average Response Time Distribution.*
- 4. The human readable Test Run Results File produced by the Workload Generator.*
- 5. A listing or screen image of all input parameters supplied to the Workload Generator.*
- 6. The total number of I/O Requests completed in the Measurement Interval as well as the number of I/O Requests with a Response Time less than or equal to 30 milliseconds and the number of I/O Requests with a Response Time greater than 30 milliseconds.*

SPC-1 Workload Generator Input Parameters

The SPC-1 Workload Generator input parameters for the Sustainability, IOPS, Response Time Ramp, Repeatability, and Persistence Test Runs are documented in [Appendix E: SPC-1 Workload Generator Input Parameters](#) on Page [73](#).

IOPS Test Results File

A link to the test results file generated from the IOPS Test Run is listed below.

[IOPS Test Results File](#)

IOPS Test Run – I/O Request Throughput Distribution Data

650 BSUs	Start	Stop	Interval	Duration
<i>Start-Up/Ramp-Up</i>	18:30:09	18:33:10	0-2	0:03:01
<i>Measurement Interval</i>	18:33:10	18:43:10	3-12	0:10:00
60 second intervals	All ASUs	ASU1	ASU2	ASU3
0	32,502.38	19,362.63	4,003.98	9,135.77
1	32,477.65	19,348.63	3,994.55	9,134.47
2	32,498.30	19,379.15	4,012.25	9,106.90
3	32,515.93	19,399.23	3,996.23	9,120.47
4	32,537.68	19,396.62	3,999.03	9,142.03
5	32,515.83	19,367.28	4,004.48	9,144.07
6	32,503.93	19,376.35	3,986.33	9,141.25
7	32,511.47	19,394.48	4,005.63	9,111.35
8	32,506.58	19,379.92	4,000.43	9,126.23
9	32,486.28	19,369.75	3,989.22	9,127.32
10	32,470.63	19,347.72	3,991.47	9,131.45
11	32,464.97	19,369.00	3,986.58	9,109.38
12	32,540.22	19,389.60	4,000.65	9,149.97
Average	32,505.35	19,379.00	3,996.01	9,130.35

IOPS Test Run – I/O Request Throughput Distribution Graph

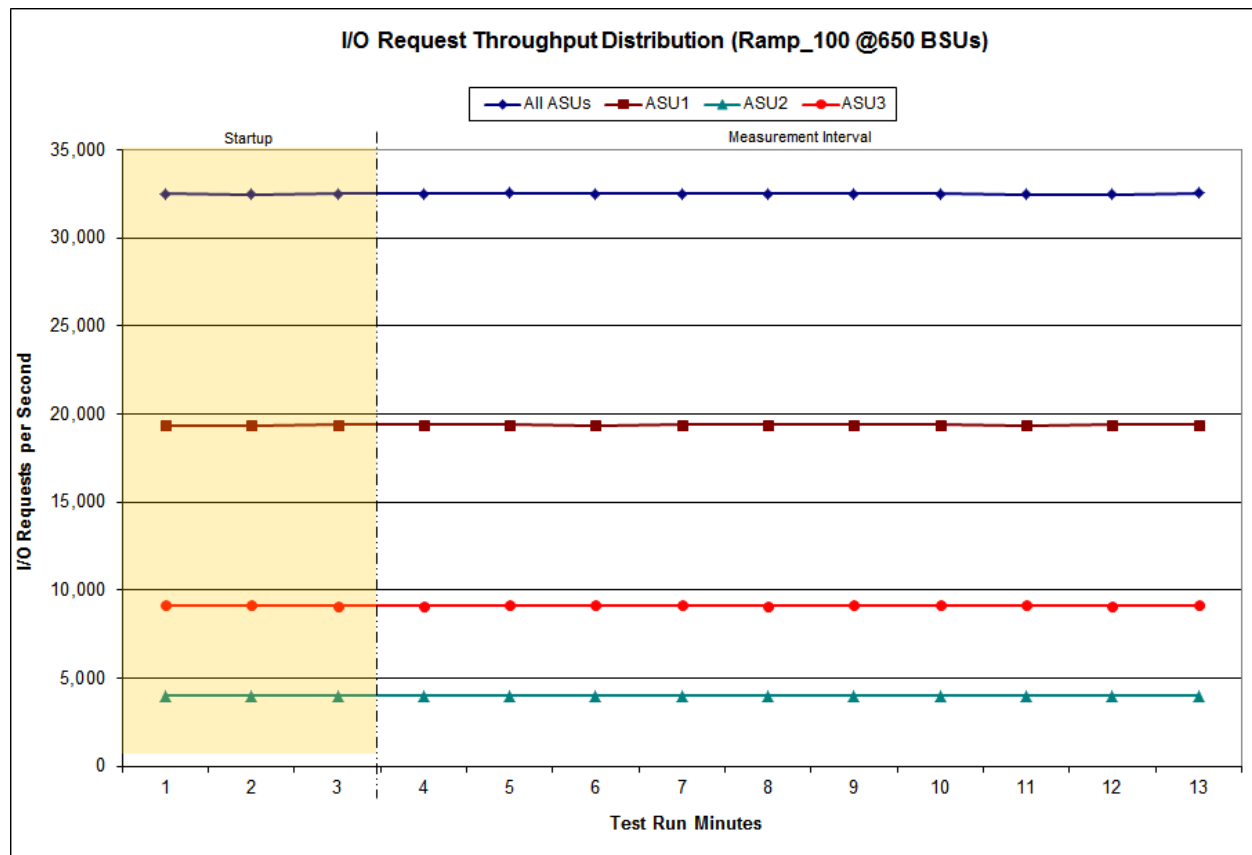

IOPS Test Run – Average Response Time (ms) Distribution Data

650 BSUs	Start	Stop	Interval	Duration
Start-Up/Ramp-Up	18:30:09	18:33:10	0-2	0:03:01
Measurement Interval	18:33:10	18:43:10	3-12	0:10:00
60 second intervals	All ASUs	ASU1	ASU2	ASU3
0	23.45	20.23	22.58	30.66
1	18.09	17.30	19.54	19.13
2	24.17	21.11	23.73	30.89
3	29.65	24.74	27.72	40.96
4	24.40	21.49	24.08	30.70
5	20.21	18.75	21.22	22.86
6	21.63	19.68	22.14	25.54
7	22.40	20.27	22.77	26.76
8	20.33	18.81	21.19	23.17
9	19.13	17.87	20.17	21.36
10	19.75	18.43	20.77	22.11
11	21.50	19.43	21.85	25.74
12	21.44	19.66	22.17	24.91
Average	22.04	19.91	22.41	26.41

IOPS Test Run – Average Response Time (ms) Distribution Graph

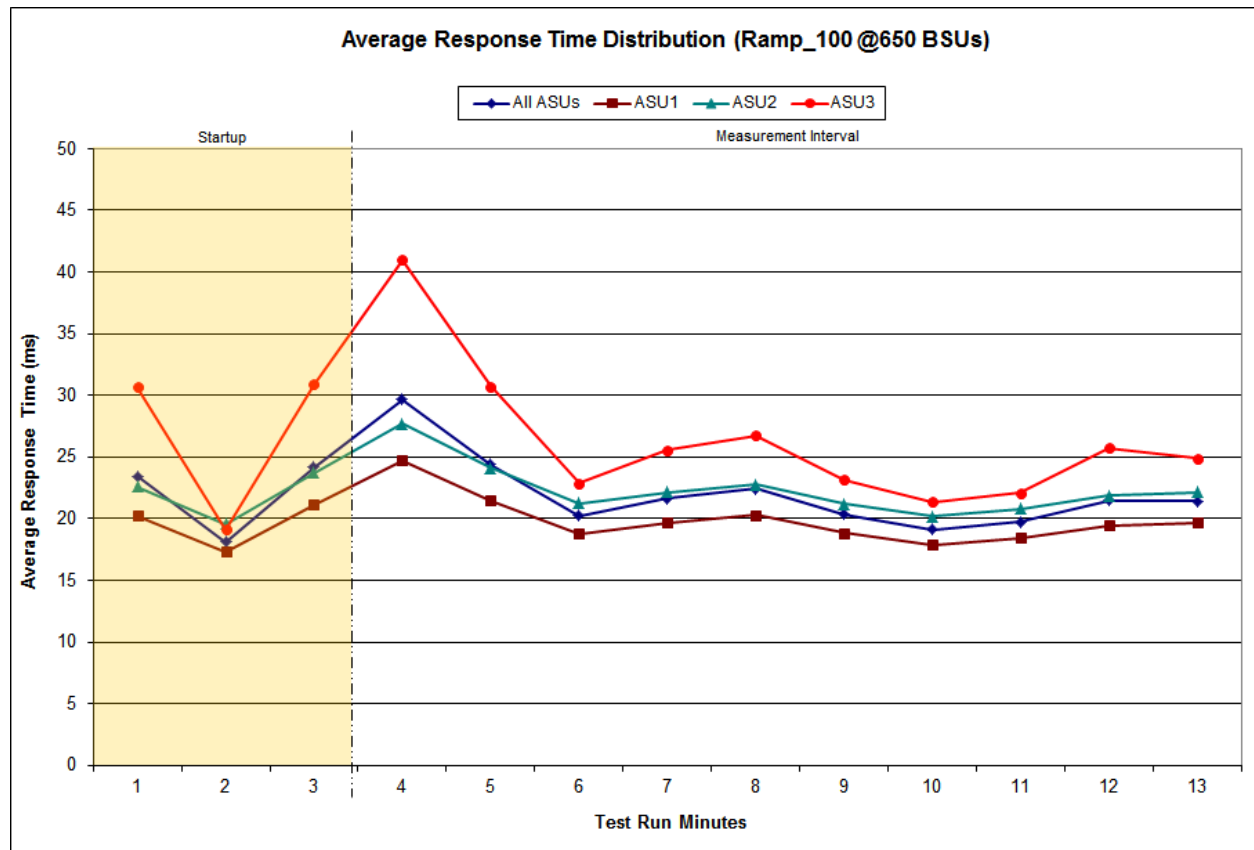

IOPS Test Run –Response Time Frequency Distribution Data

Response Time (ms)	0-0.25	>0.25-0.5	>0.5-0.75	>0.75-1.0	>1.0-1.25	>1.25-1.5	>1.5-1.75	>1.75-2.0
Read	969	2,921	5,592	7,441	7,503	6,989	6,880	6,940
Write	0	-	-	-	-	-	-	-
All ASUs	969	2,921	5,592	7,441	7,503	6,989	6,880	6,940
ASU1	898	2,688	5,160	6,871	6,898	6,401	6,277	6,241
ASU2	71	233	432	570	605	588	603	699
ASU3	0	-	-	-	-	-	-	-
Response Time (ms)	>2.0-2.5	>2.5-3.0	>3.0-3.5	>3.5-4.0	>4.0-4.5	>4.5-5.0	>5.0-6.0	>6.0-7.0
Read	14,292	15,908	19,162	24,439	33,625	48,650	162,100	275,678
Write	-	-	-	-	-	2	6	7
All ASUs	14,292	15,908	19,162	24,439	33,625	48,652	162,106	275,685
ASU1	12,874	14,025	16,532	20,717	28,041	40,542	136,527	236,800
ASU2	1,418	1,883	2,630	3,722	5,584	8,110	25,578	38,884
ASU3	-	-	-	-	-	-	1	1
Response Time (ms)	>7.0-8.0	>8.0-9.0	>9.0-10.0	>10.0-15.0	>15.0-20.0	>20.0-25.0	>25.0-30.0	>30.0
Read	381,477	452,499	490,861	2,252,120	900,363	1,151,256	522,547	904,268
Write	233	3,779	45,332	4,097,558	2,422,434	1,764,463	1,113,140	2,360,567
All ASUs	381,710	456,278	536,193	6,349,678	3,322,797	2,915,719	1,635,687	3,264,835
ASU1	332,307	397,860	453,010	3,879,235	1,864,917	1,712,143	856,447	1,583,400
ASU2	49,320	56,987	65,476	741,426	389,813	368,246	196,486	438,090
ASU3	83	1,431	17,707	1,729,017	1,068,067	835,330	582,754	1,243,345

IOPS Test Run –Response Time Frequency Distribution Graph

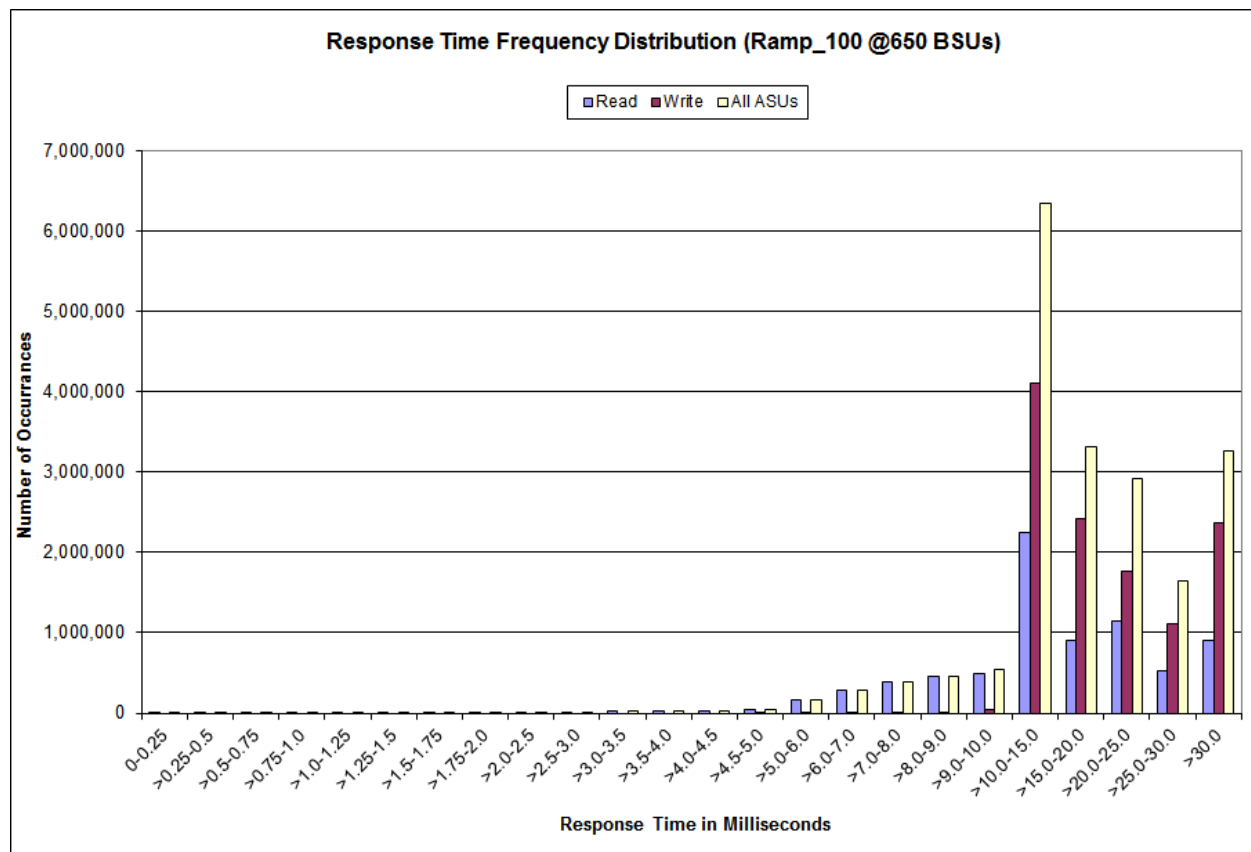

IOPS Test Run – I/O Request Information

I/O Requests Completed in the Measurement Interval	I/O Requests Completed with Response Time = or < 30 ms	I/O Requests Completed with Response Time > 30 ms
19,502,001	16,237,166	3,264,835

IOPS Test Run – Measured Intensity Multiplier and Coefficient of Variation

Clause 3.4.3

IM – Intensity Multiplier: The ratio of I/Os for each I/O stream relative to the total I/Os for all I/O streams (ASU1-1 – ASU3-1) as required by the benchmark specification.

Clauses 5.1.10 and 5.3.15.2

MIM – Measured Intensity Multiplier: The Measured Intensity Multiplier represents the ratio of measured I/Os for each I/O stream relative to the total I/Os measured for all I/O streams (ASU1-1 – ASU3-1). This value may differ from the corresponding Expected Intensity Multiplier by no more than 5%.

Clause 5.3.15.3

COV – Coefficient of Variation: This measure of variation for the Measured Intensity Multiplier cannot exceed 0.2.

	ASU1-1	ASU1-2	ASU1-3	ASU1-4	ASU2-1	ASU2-2	ASU2-3	ASU3-1
IM	0.0350	0.2810	0.0700	0.2100	0.0180	0.0700	0.0350	0.2810
MIM	0.0350	0.2810	0.0700	0.2101	0.0180	0.0699	0.0351	0.2809
COV	0.003	0.002	0.003	0.002	0.004	0.003	0.003	0.001

Primary Metrics Test – Response Time Ramp Test Phase

Clause 5.4.4.3

The Response Time Ramp Test Phase consists of five Test Runs, one each at 95%, 90%, 80%, 50%, and 10% of the load point (100%) used to generate the SPC-1 IOPS™ primary metric. Each of the five Test Runs has a Measurement Interval of ten (10) minutes. The Response Time Ramp Test Phase immediately follows the IOPS Test Phase without any interruption or manual intervention.

The five Response Time Ramp Test Runs, in conjunction with the IOPS Test Run (100%), demonstrate the relationship between Average Response Time and I/O Request Throughput for the Tested Storage Configuration (TSC) as illustrated in the response time/throughput curve on page 15.

In addition, the Average Response Time measured during the 10% Test Run is the value for the SPC-1 LRT™ metric. That value represents the Average Response Time of a lightly loaded TSC.

Clause 9.4.3.7.4

The following content shall appear in the FDR for the Response Time Ramp Phase:

- 1. A Response Time Ramp Distribution.*
- 2. The human readable Test Run Results File produced by the Workload Generator for each Test Run within the Response Time Ramp Test Phase.*
- 3. For the 10% Load Level Test Run (SPC-1 LRT™ metric) an Average Response Time Distribution.*
- 4. A listing or screen image of all input parameters supplied to the Workload Generator.*

SPC-1 Workload Generator Input Parameters

The SPC-1 Workload Generator input parameters for the Sustainability, IOPS, Response Time Ramp, Repeatability, and Persistence Test Runs are documented in [Appendix E: SPC-1 Workload Generator Input Parameters](#) on Page [73](#).

Response Time Ramp Test Results File

A link to each test result file generated from each Response Time Ramp Test Run list listed below.

[95% Load Level](#)

[90% Load Level](#)

[80% Load Level](#)

[50% Load Level](#)

[10% Load Level](#)

Response Time Ramp Distribution (IOPS) Data

The five Test Runs that comprise the Response Time Ramp Phase are executed at 95%, 90%, 80%, 50%, and 10% of the Business Scaling Unit (BSU) load level used to produce the SPC-1 IOPS™ primary metric. The 100% BSU load level is included in the following Response Time Ramp data table and graph for completeness.

100% Load Level: 650 BSUs					95% Load Level: 617 BSUs				
	Start	Stop	Interval	Duration		Start	Stop	Interval	Duration
Start-Up/Ramp-Up	18:30:09	18:33:10	0-3	0:03:01	Start-Up/Ramp-Up	18:43:16	18:46:17	0-3	0:03:01
Measurement Interval	18:33:10	18:43:10	3-12	0:10:00	Measurement Interval	18:46:17	18:56:17	3-12	0:10:00
<i>(60 second intervals)</i>	All ASUs	ASU-1	ASU-2	ASU-3	<i>(60 second intervals)</i>	All ASUs	ASU-1	ASU-2	ASU-3
0	32,502.38	19,362.63	4,003.98	9,135.77	0	30,860.95	18,408.73	3,792.77	8,659.45
1	32,477.65	19,348.63	3,994.55	9,134.47	1	30,849.50	18,397.80	3,793.68	8,658.02
2	32,498.30	19,379.15	4,012.25	9,106.90	2	30,829.43	18,382.52	3,796.72	8,650.20
3	32,515.93	19,399.23	3,996.23	9,120.47	3	30,823.13	18,352.43	3,809.75	8,660.95
4	32,537.68	19,396.62	3,999.03	9,142.03	4	30,841.08	18,382.93	3,797.35	8,660.80
5	32,515.83	19,367.28	4,004.48	9,144.07	5	30,852.63	18,378.07	3,791.05	8,683.52
6	32,503.93	19,376.35	3,986.33	9,141.25	6	30,822.35	18,369.57	3,802.72	8,650.07
7	32,511.47	19,394.48	4,005.63	9,111.35	7	30,824.38	18,387.05	3,772.67	8,664.67
8	32,506.58	19,379.92	4,000.43	9,126.23	8	30,824.02	18,370.73	3,788.02	8,665.27
9	32,486.28	19,369.75	3,989.22	9,127.32	9	30,846.80	18,370.05	3,801.85	8,674.90
10	32,470.63	19,347.72	3,991.47	9,131.45	10	30,834.80	18,371.62	3,799.25	8,663.93
11	32,464.97	19,369.00	3,986.58	9,109.38	11	30,877.73	18,411.38	3,808.68	8,657.67
12	32,540.22	19,389.60	4,000.65	9,149.97	12	30,854.57	18,379.35	3,801.55	8,673.67
Average	32,505.35	19,379.00	3,996.01	9,130.35	Average	30,840.15	18,377.32	3,797.29	8,665.54
90% Load Level: 585 BSUs					80% Load Level: 520 BSUs				
	Start	Stop	Interval	Duration		Start	Stop	Interval	Duration
Start-Up/Ramp-Up	18:56:23	18:59:24	0-3	0:03:01	Start-Up/Ramp-Up	19:09:29	19:12:30	0-3	0:03:01
Measurement Interval	18:59:24	19:09:24	3-12	0:10:00	Measurement Interval	19:12:30	19:22:30	3-12	0:10:00
<i>(60 second intervals)</i>	All ASUs	ASU-1	ASU-2	ASU-3	<i>(60 second intervals)</i>	All ASUs	ASU-1	ASU-2	ASU-3
0	29,267.78	17,443.18	3,588.68	8,235.92	0	26,014.17	15,502.27	3,195.37	7,316.53
1	29,231.05	17,410.57	3,602.62	8,217.87	1	25,970.68	15,487.45	3,193.97	7,289.27
2	29,206.78	17,403.93	3,589.80	8,213.05	2	26,010.67	15,510.75	3,189.08	7,310.83
3	29,275.63	17,456.78	3,608.08	8,210.77	3	25,998.38	15,497.50	3,190.23	7,310.65
4	29,245.93	17,440.55	3,592.62	8,212.77	4	25,938.32	15,444.70	3,190.42	7,303.20
5	29,255.85	17,412.25	3,597.22	8,246.38	5	25,976.58	15,483.58	3,190.45	7,302.55
6	29,246.77	17,447.63	3,595.70	8,203.43	6	26,010.98	15,479.38	3,195.60	7,336.00
7	29,200.82	17,406.33	3,588.13	8,206.35	7	26,051.90	15,516.62	3,210.87	7,324.42
8	29,256.63	17,439.53	3,590.55	8,226.55	8	25,971.97	15,484.78	3,194.20	7,292.98
9	29,248.62	17,440.20	3,595.23	8,213.18	9	26,003.90	15,489.93	3,197.32	7,316.65
10	29,250.75	17,436.72	3,587.60	8,226.43	10	25,979.18	15,479.43	3,204.18	7,295.57
11	29,231.22	17,436.25	3,602.43	8,192.53	11	25,966.38	15,465.92	3,189.90	7,310.57
12	29,229.23	17,434.17	3,608.88	8,186.18	12	26,018.32	15,507.83	3,200.18	7,310.30
Average	29,244.15	17,435.04	3,596.65	8,212.46	Average	25,991.59	15,484.97	3,196.34	7,310.29

Response Time Ramp Distribution (IOPS) Data (continued)

50% Load Level: 325 BSUs					10% Load Level: 66 BSUs				
	Start	Stop	Interval	Duration		Start	Stop	Interval	Duration
Start-Up/Ramp-Up	19:22:35	19:25:36	0-3	0:03:01	Start-Up/Ramp-Up	19:35:41	19:38:42	0-3	0:03:01
Measurement Interval	19:25:36	19:35:36	3-12	0:10:00	Measurement Interval	19:38:42	19:48:42	3-12	0:10:00
(60 second intervals)	All ASUs	ASU-1	ASU-2	ASU-3	(60 second intervals)	All ASUs	ASU-1	ASU-2	ASU-3
0	16,241.12	9,673.30	1,999.80	4,568.02	0	3,251.13	1,933.30	401.75	916.08
1	16,251.78	9,679.95	2,011.90	4,559.93	1	3,253.58	1,944.42	394.70	914.47
2	16,245.73	9,685.12	1,996.57	4,564.05	2	3,247.48	1,939.47	397.75	910.27
3	16,252.48	9,697.22	1,994.40	4,560.87	3	3,242.15	1,934.20	398.75	909.20
4	16,253.12	9,691.82	1,998.38	4,562.92	4	3,251.15	1,945.20	398.20	907.75
5	16,229.60	9,694.50	1,981.78	4,553.32	5	3,251.18	1,927.13	402.90	921.15
6	16,261.57	9,702.43	2,000.20	4,558.93	6	3,249.77	1,938.80	397.88	913.08
7	16,238.00	9,681.63	1,990.68	4,565.68	7	3,233.23	1,929.20	393.35	910.68
8	16,247.92	9,688.43	1,998.45	4,561.03	8	3,248.48	1,931.77	398.70	918.02
9	16,254.97	9,694.48	1,993.60	4,566.88	9	3,247.52	1,931.53	396.93	919.05
10	16,232.48	9,676.78	1,999.65	4,556.05	10	3,247.00	1,932.32	399.77	914.92
11	16,239.82	9,689.95	1,997.98	4,551.88	11	3,250.07	1,935.32	398.27	916.48
12	16,268.75	9,684.87	2,003.35	4,580.53	12	3,253.80	1,938.87	396.92	918.02
Average	16,247.87	9,690.21	1,995.85	4,561.81	Average	3,247.44	1,934.43	398.17	914.84

Response Time Ramp Distribution (IOPS) Graph

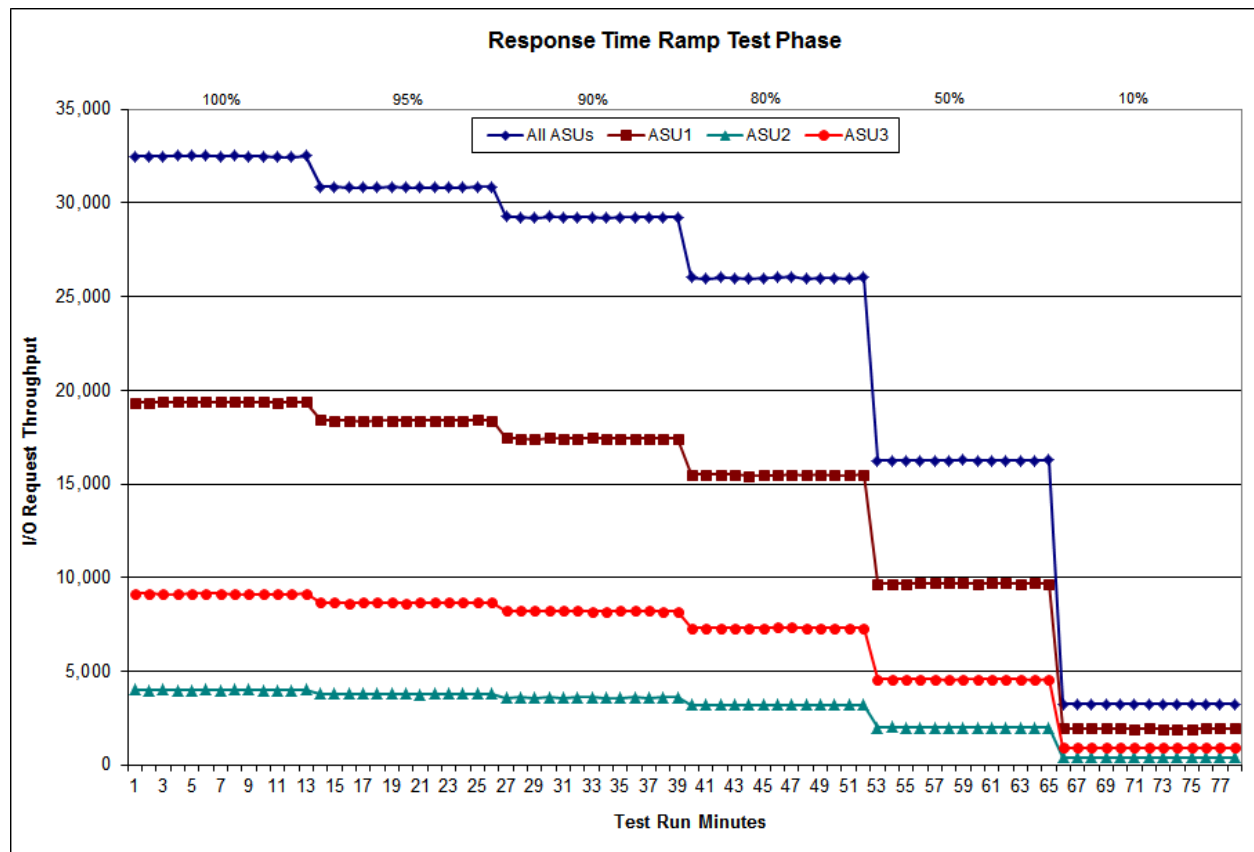

SPC-1 LRT™ Average Response Time (ms) Distribution Data

65 BSUs	Start	Stop	Interval	Duration
Start-Up/Ramp-Up	19:35:41	19:38:42	0-2	0:03:01
Measurement Interval	19:38:42	19:48:42	3-12	0:10:00
60 second intervals	All ASUs	ASU1	ASU2	ASU3
0	3.19	3.68	3.54	2.00
1	3.27	3.72	3.60	2.17
2	3.10	3.55	3.42	2.00
3	3.21	3.65	3.44	2.15
4	3.35	3.80	3.57	2.30
5	3.45	3.92	3.46	2.44
6	3.40	3.92	3.43	2.27
7	3.43	3.91	3.49	2.39
8	3.50	3.96	3.50	2.52
9	3.41	3.88	3.50	2.39
10	3.49	3.95	3.53	2.51
11	3.42	3.88	3.48	2.42
12	3.39	3.89	3.42	2.34
Average	3.40	3.88	3.48	2.37

SPC-1 LRT™ Average Response Time (ms) Distribution Graph

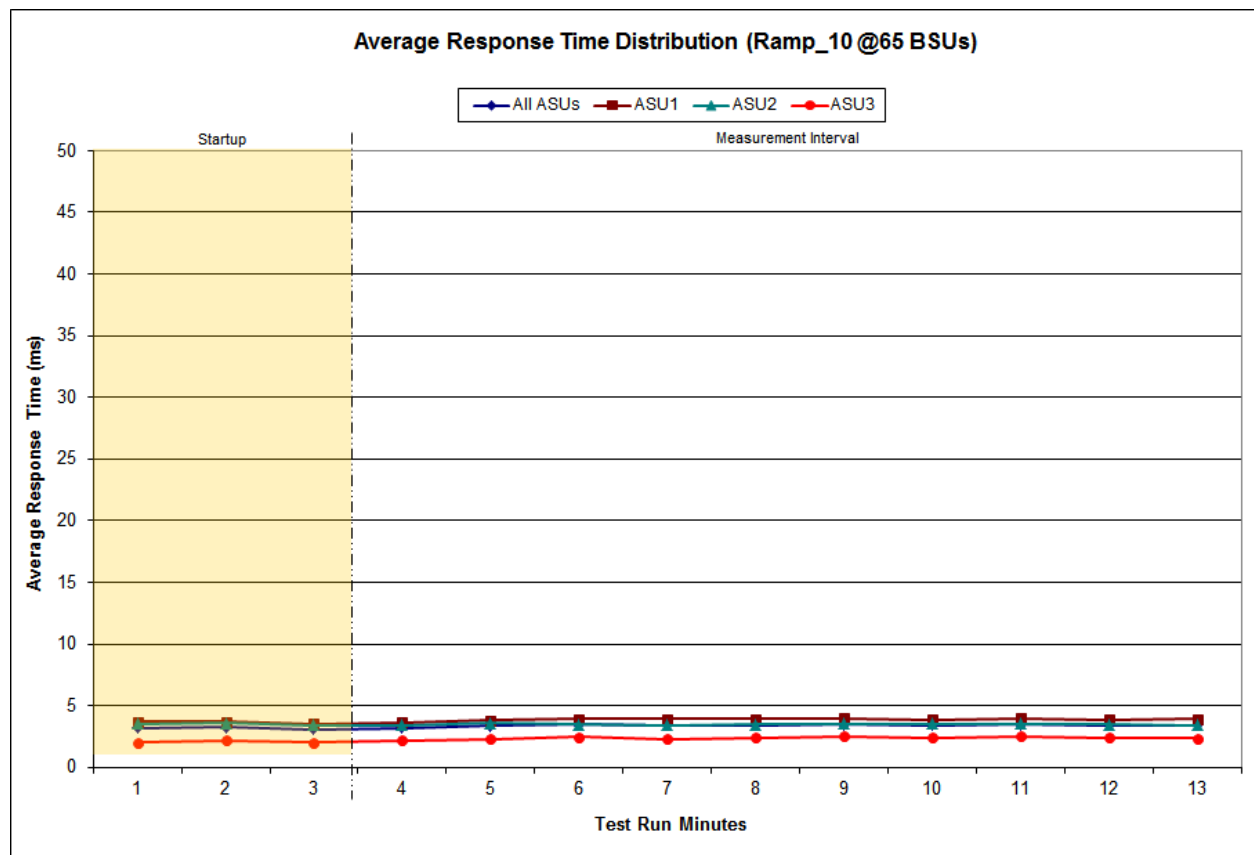

SPC-1 LRT™ (10%) – Measured Intensity Multiplier and Coefficient of Variation

Clause 3.4.3

IM – Intensity Multiplier: The ratio of I/Os for each I/O stream relative to the total I/Os for all I/O streams (ASU1-1 – ASU3-1) as required by the benchmark specification.

Clauses 5.1.10 and 5.3.15.2

MIM – Measured Intensity Multiplier: The Measured Intensity Multiplier represents the ratio of measured I/Os for each I/O stream relative to the total I/Os measured for all I/O streams (ASU1-1 – ASU3-1). This value may differ from the corresponding Expected Intensity Multiplier by no more than 5%.

Clause 5.3.15.3

COV – Coefficient of Variation: This measure of variation for the Measured Intensity Multiplier cannot exceed 0.2.

	ASU1-1	ASU1-2	ASU1-3	ASU1-4	ASU2-1	ASU2-2	ASU2-3	ASU3-1
IM	0.0350	0.2810	0.0700	0.2100	0.0180	0.0700	0.0350	0.2810
MIM	0.0348	0.2815	0.0698	0.2096	0.0179	0.0699	0.0348	0.2817
COV	0.011	0.004	0.006	0.003	0.018	0.009	0.011	0.004

Repeatability Test

Clause 5.4.5

The Repeatability Test demonstrates the repeatability and reproducibility of the SPC-1 IOPS™ primary metric and the SPC-1 LRT™ metric generated in earlier Test Runs.

There are two identical Repeatability Test Phases. Each Test Phase contains two Test Runs. Each of the Test Runs will have a Measurement Interval of no less than ten (10) minutes. The two Test Runs in each Test Phase will be executed without interruption or any type of manual intervention.

The first Test Run in each Test Phase is executed at the 10% load point. The Average Response Time from each of the Test Runs is compared to the SPC-1 LRT™ metric. Each Average Response Time value must be less than the SPC-1 LRT™ metric plus 5% or less than the SPC-1 LRT™ metric plus one (1) millisecond (ms).

The second Test Run in each Test Phase is executed at the 100% load point. The I/O Request Throughput from the Test Runs is compared to the SPC-1 IOPS™ primary metric. Each I/O Request Throughput value must be greater than the SPC-1 IOPS™ primary metric minus 5%. In addition, the Average Response Time for each Test Run cannot exceed 30 milliseconds.

If any of the above constraints are not met, the benchmark measurement is invalid.

Clause 9.4.3.7.5

The following content shall appear in the FDR for each Test Run in the two Repeatability Test Phases:

- 1. A table containing the results of the Repeatability Test.*
- 2. An I/O Request Throughput Distribution graph and table.*
- 3. An Average Response Time Distribution graph and table.*
- 4. The human readable Test Run Results File produced by the Workload Generator.*
- 5. A listing or screen image of all input parameters supplied to the Workload Generator.*

SPC-1 Workload Generator Input Parameters

The SPC-1 Workload Generator input parameters for the Sustainability, IOPS, Response Time Ramp, Repeatability, and Persistence Test Runs are documented in [Appendix E: SPC-1 Workload Generator Input Parameters](#) on Page [73](#).

Repeatability Test Results File

The values for the SPC-1 IOPS™, SPC-1 LRT™, and the Repeatability Test measurements are listed in the tables below.

	SPC-1 IOPS™
Primary Metrics	32,505.35
Repeatability Test Phase 1	32,494.40
Repeatability Test Phase 2	32,494.16

The SPC-1 IOPS™ values in the above table were generated using 100% of the specified Business Scaling Unit (BSU) load level. Each of the Repeatability Test Phase values for SPC-1 IOPS™ must be greater than 95% of the reported SPC-1 IOPS™ Primary Metric.

	SPC-1 LRT™
Primary Metrics	3.40 ms
Repeatability Test Phase 1	3.38 ms
Repeatability Test Phase 2	3.31 ms

The average response time values in the SPC-1 LRT™ column were generated using 10% of the specified Business Scaling Unit (BSU) load level. Each of the Repeatability Test Phase values for SPC-1 LRT™ must be less than 105% of the reported SPC-1 LRT™ Primary Metric or less than the reported SPC-1 LRT™ Primary Metric plus one (1) millisecond (ms).

A link to the test result file generated from each Repeatability Test Run is listed below.

- [Repeatability Test Phase 1, Test Run 1 \(LRT\)](#)
- [Repeatability Test Phase 1, Test Run 2 \(IOPS\)](#)
- [Repeatability Test Phase 2, Test Run 1 \(LRT\)](#)
- [Repeatability Test Phase 2, Test Run 2 \(IOPS\)](#)

Repeatability 1 LRT – I/O Request Throughput Distribution Data

65 BSUs Start-Up/Ramp-Up Measurement Interval	Start	Stop	Interval	Duration
	19:48:55	19:51:55	0-2	0:03:00
	19:51:55	20:01:55	3-12	0:10:00
60 second intervals	All ASUs	ASU1	ASU2	ASU3
0	3,258.05	1,937.13	396.75	924.17
1	3,249.48	1,941.42	400.43	907.63
2	3,243.55	1,932.15	396.65	914.75
3	3,243.13	1,928.73	401.22	913.18
4	3,252.37	1,939.75	398.12	914.50
5	3,259.27	1,939.22	401.30	918.75
6	3,255.72	1,940.80	399.75	915.17
7	3,246.28	1,938.00	400.13	908.15
8	3,254.87	1,939.48	405.47	909.92
9	3,250.77	1,939.42	403.30	908.05
10	3,253.95	1,940.38	398.92	914.65
11	3,264.15	1,945.20	399.63	919.32
12	3,243.82	1,935.72	398.90	909.20
Average	3,252.43	1,938.67	400.67	913.09

Repeatability 1 LRT – I/O Request Throughput Distribution Graph

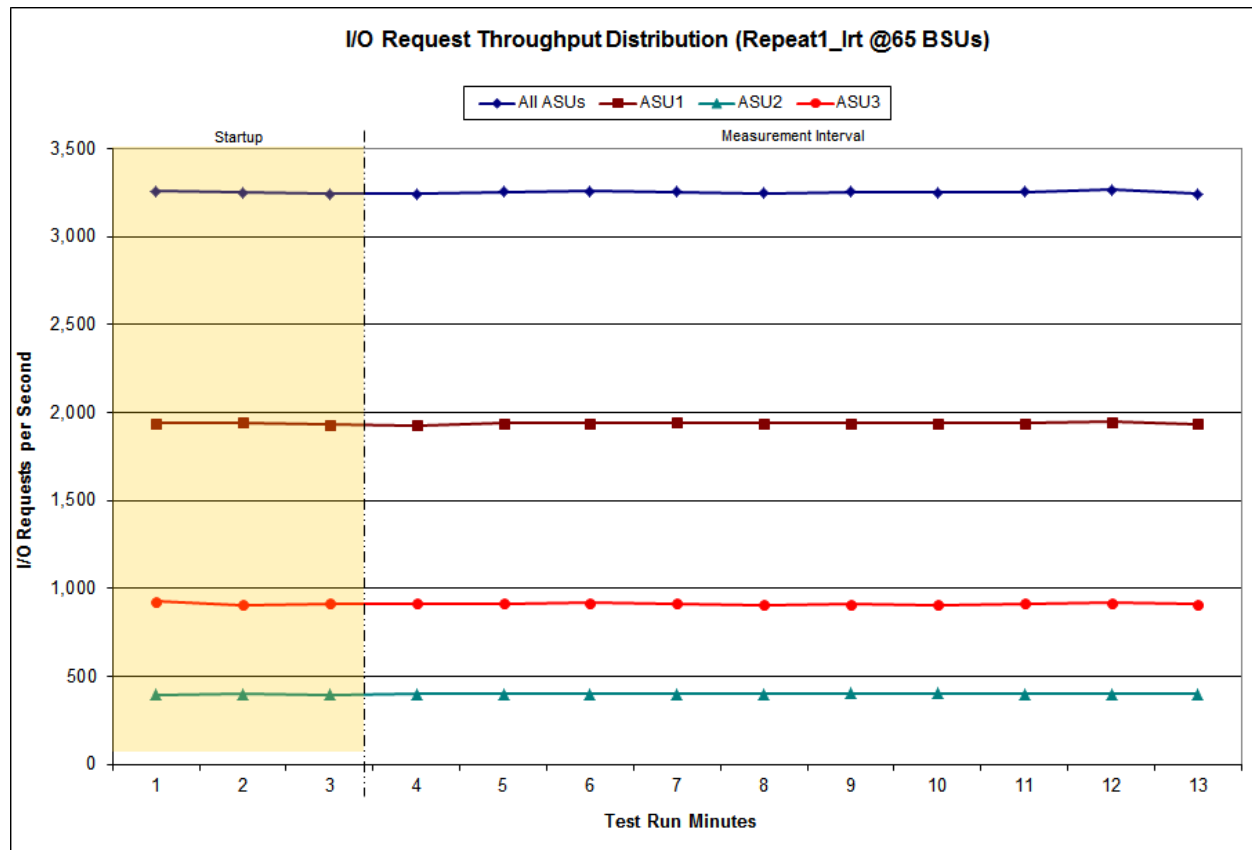

Repeatability 1 LRT –Average Response Time (ms) Distribution Data

65 BSUs	Start	Stop	Interval	Duration
<i>Start-Up/Ramp-Up</i>	19:48:55	19:51:55	0-2	0:03:00
<i>Measurement Interval</i>	19:51:55	20:01:55	3-12	0:10:00
60 second intervals	All ASUs	ASU1	ASU2	ASU3
0	3.47	3.96	3.48	2.42
1	3.54	4.04	3.56	2.48
2	3.56	4.06	3.76	2.42
3	3.37	3.84	3.44	2.36
4	3.36	3.83	3.45	2.35
5	3.36	3.81	3.40	2.40
6	3.39	3.85	3.42	2.41
7	3.37	3.82	3.42	2.38
8	3.39	3.86	3.41	2.39
9	3.37	3.81	3.44	2.40
10	3.42	3.85	3.51	2.48
11	3.40	3.85	3.43	2.42
12	3.32	3.80	3.40	2.27
Average	3.38	3.83	3.43	2.39

Repeatability 1 LRT –Average Response Time (ms) Distribution Graph

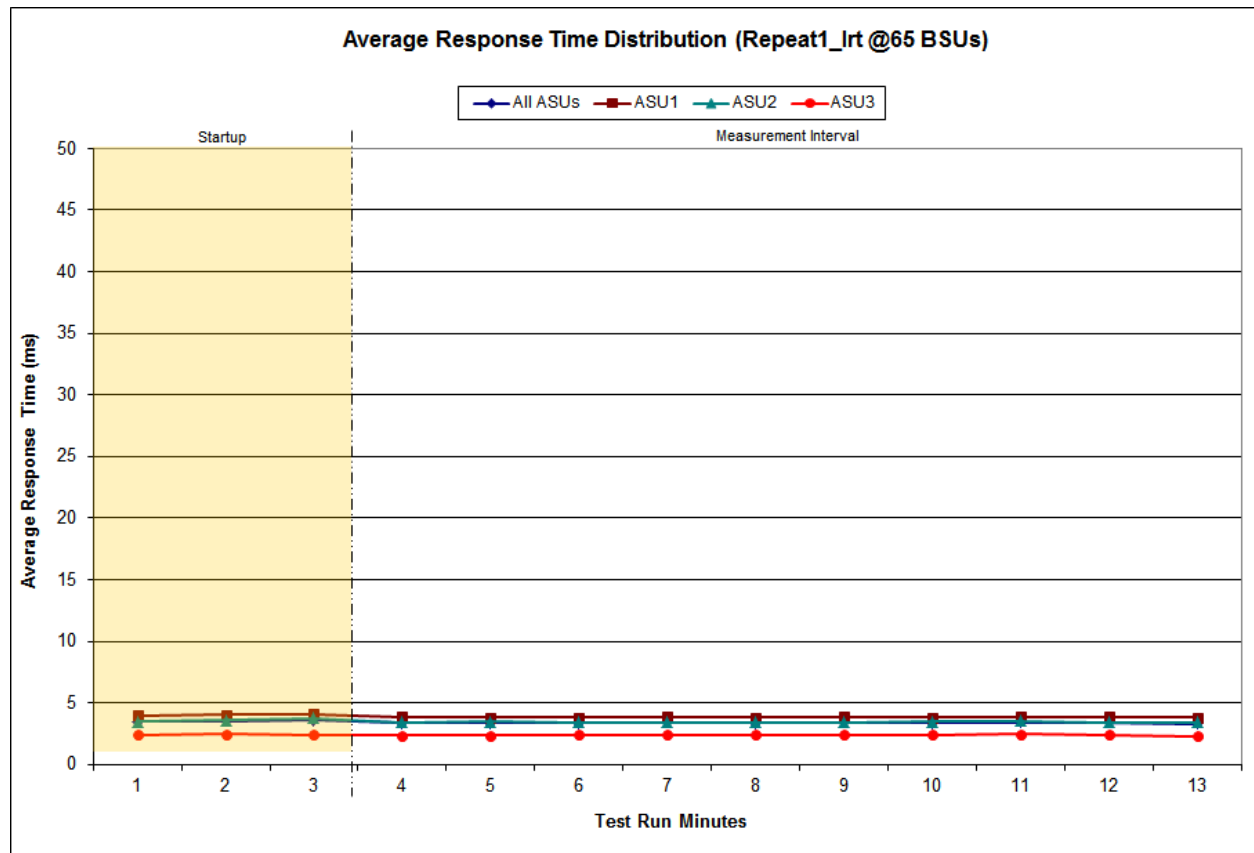

Repeatability 1 IOPS – I/O Request Throughput Distribution Data

650 BSUs Start-Up/Ramp-Up Measurement Interval	Start	Stop	Interval	Duration
	20:02:02	20:05:03	0-2	0:03:01
	20:05:03	20:15:03	3-12	0:10:00
60 second intervals	All ASUs	ASU1	ASU2	ASU3
0	32,514.93	19,379.42	4,005.52	9,130.00
1	32,495.03	19,362.17	4,006.75	9,126.12
2	32,472.80	19,355.20	3,998.90	9,118.70
3	32,470.08	19,357.02	3,978.93	9,134.13
4	32,492.80	19,363.88	3,987.52	9,141.40
5	32,498.48	19,371.35	4,001.15	9,125.98
6	32,506.45	19,378.58	4,000.07	9,127.80
7	32,488.22	19,349.30	4,006.37	9,132.55
8	32,484.35	19,359.83	3,991.65	9,132.87
9	32,489.60	19,364.03	4,007.65	9,117.92
10	32,510.20	19,365.52	4,009.55	9,135.13
11	32,470.52	19,353.90	3,984.93	9,131.68
12	32,533.27	19,392.78	4,001.40	9,139.08
Average	32,494.40	19,365.62	3,996.92	9,131.86

Repeatability 1 IOPS – I/O Request Throughput Distribution Graph

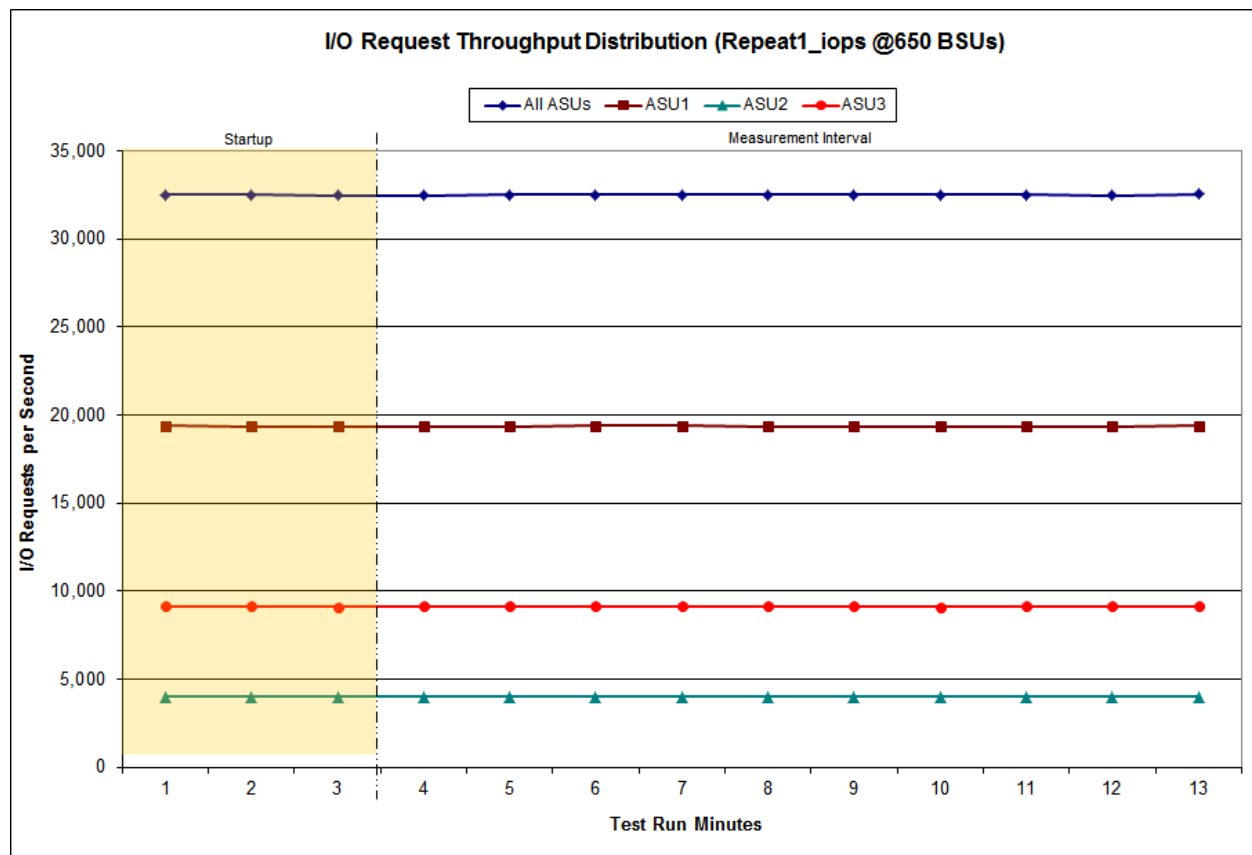

Repeatability 1 IOPS –Average Response Time (ms) Distribution Data

650 BSUs	Start	Stop	Interval	Duration
<i>Start-Up/Ramp-Up</i>	20:02:02	20:05:03	0-2	0:03:01
<i>Measurement Interval</i>	20:05:03	20:15:03	3-12	0:10:00
60 second intervals	All ASUs	ASU1	ASU2	ASU3
0	15.46	14.37	15.77	17.63
1	21.42	19.55	21.93	25.17
2	22.34	20.09	22.61	27.02
3	17.73	16.90	19.13	18.88
4	21.68	19.70	22.16	25.68
5	20.42	18.85	21.18	23.40
6	22.09	20.04	22.52	26.26
7	18.88	17.77	20.01	20.76
8	18.11	17.20	19.40	19.49
9	17.78	16.96	19.11	18.92
10	21.01	19.20	21.58	24.58
11	19.70	18.32	20.71	22.21
12	21.61	19.74	22.18	25.32
Average	19.90	18.47	20.80	22.55

Repeatability 1 IOPS –Average Response Time (ms) Distribution Graph

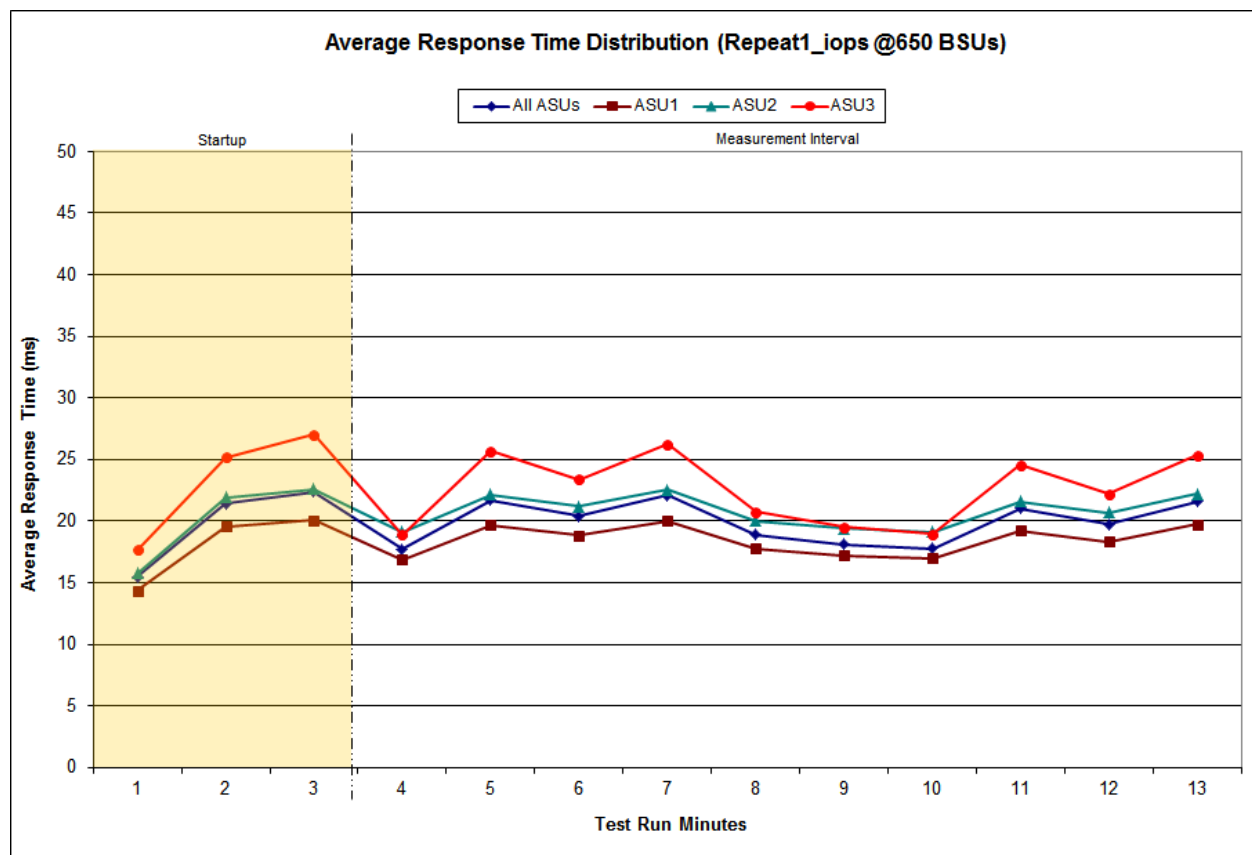

Repeatability 2 LRT – I/O Request Throughput Distribution Data

65 BSUs	Start	Stop	Interval	Duration
Start-Up/Ramp-Up	20:15:16	20:18:16	0-2	0:03:00
Measurement Interval	20:18:16	20:28:16	3-12	0:10:00
60 second intervals	All ASUs	ASU1	ASU2	ASU3
0	3,253.77	1,939.47	401.18	913.12
1	3,242.93	1,929.27	397.52	916.15
2	3,238.97	1,934.02	393.17	911.78
3	3,256.18	1,943.58	398.42	914.18
4	3,246.03	1,937.85	398.83	909.35
5	3,254.28	1,939.77	403.22	911.30
6	3,249.13	1,939.42	396.05	913.67
7	3,242.65	1,932.80	396.57	913.28
8	3,243.50	1,938.60	400.65	904.25
9	3,257.32	1,941.67	396.63	919.02
10	3,261.70	1,947.37	399.05	915.28
11	3,242.25	1,929.83	397.43	914.98
12	3,249.32	1,936.00	401.22	912.10
Average	3,250.24	1,938.69	398.81	912.74

Repeatability 2 LRT – I/O Request Throughput Distribution Graph

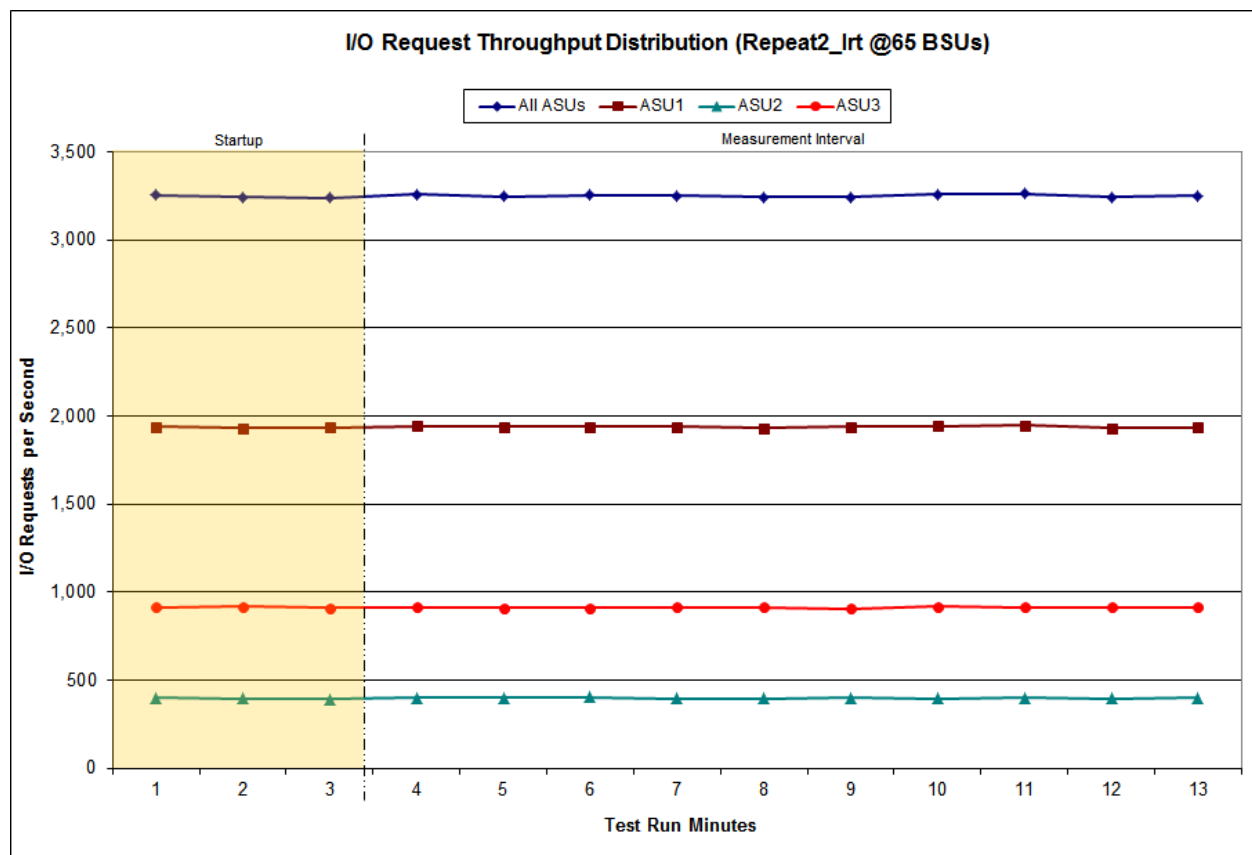

Repeatability 2 LRT –Average Response Time (ms) Distribution Data

65 BSUs Start-Up/Ramp-Up Measurement Interval	Start	Stop	Interval	Duration
	20:15:16	20:18:16	0-2	0:03:00
	20:18:16	20:28:16	3-12	0:10:00
60 second intervals	All ASUs	ASU1	ASU2	ASU3
0	3.18	3.67	3.47	2.03
1	3.21	3.66	3.52	2.12
2	3.12	3.54	3.38	2.10
3	3.12	3.53	3.40	2.14
4	3.14	3.58	3.32	2.13
5	3.41	3.84	3.48	2.47
6	3.34	3.78	3.44	2.37
7	3.37	3.80	3.41	2.42
8	3.36	3.83	3.38	2.35
9	3.32	3.77	3.34	2.35
10	3.34	3.78	3.43	2.37
11	3.32	3.77	3.37	2.34
12	3.34	3.78	3.44	2.36
Average	3.31	3.75	3.40	2.33

Repeatability 2 LRT –Average Response Time (ms) Distribution Graph

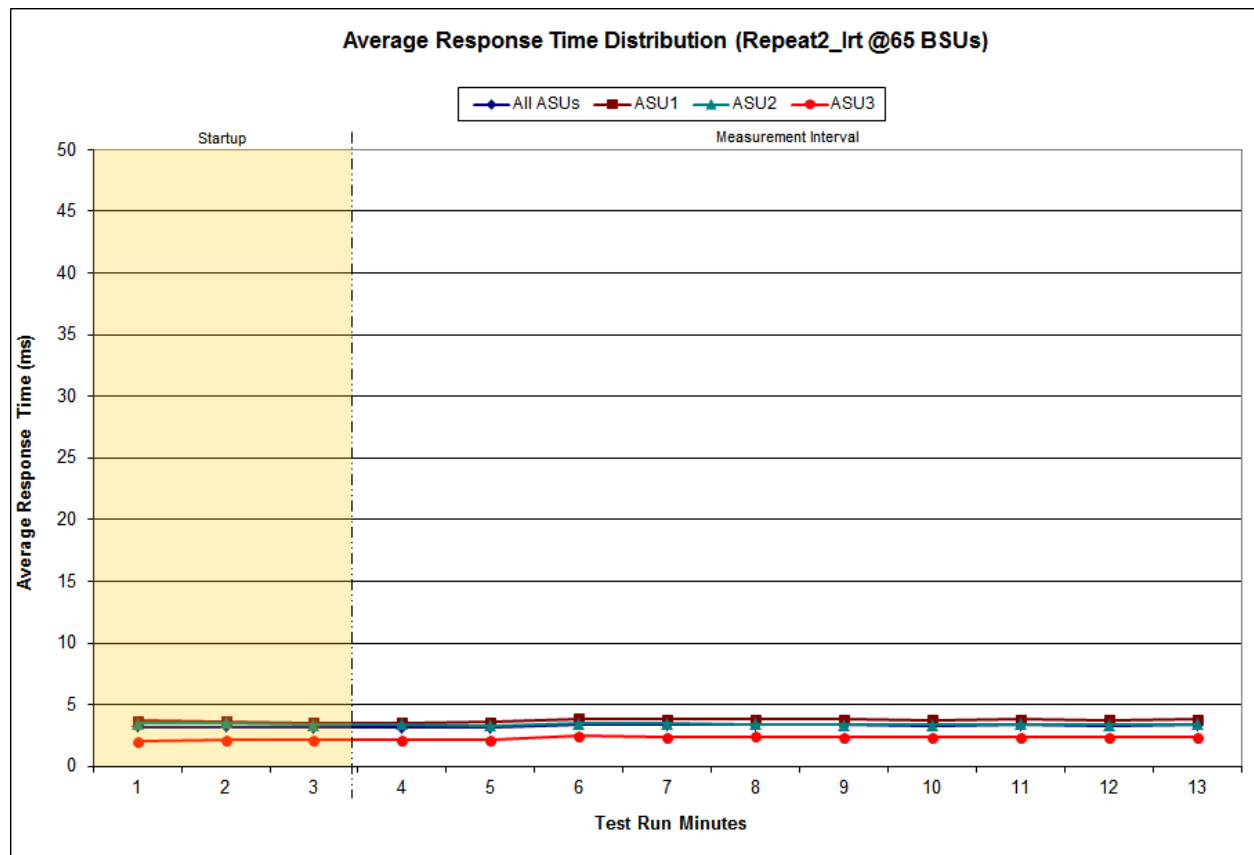

Repeatability 2 IOPS – I/O Request Throughput Distribution Data

650 BSUs	Start	Stop	Interval	Duration
<i>Start-Up/Ramp-Up</i>	20:28:23	20:31:24	0-2	0:03:01
<i>Measurement Interval</i>	20:31:24	20:41:24	3-12	0:10:00
60 second intervals	All ASUs	ASU1	ASU2	ASU3
0	32,523.52	19,402.17	3,999.33	9,122.02
1	32,476.55	19,363.92	3,985.57	9,127.07
2	32,494.17	19,356.67	4,001.72	9,135.78
3	32,493.70	19,377.40	3,994.73	9,121.57
4	32,461.95	19,330.13	3,991.25	9,140.57
5	32,496.82	19,381.58	3,999.37	9,115.87
6	32,507.02	19,383.17	4,004.65	9,119.20
7	32,522.02	19,372.67	4,003.55	9,145.80
8	32,481.15	19,366.82	3,986.80	9,127.53
9	32,484.28	19,354.93	4,003.05	9,126.30
10	32,493.68	19,352.53	4,001.68	9,139.47
11	32,498.25	19,369.40	3,991.17	9,137.68
12	32,502.70	19,367.35	4,003.73	9,131.62
Average	32,494.16	19,365.60	3,998.00	9,130.56

Repeatability 2 IOPS – I/O Request Throughput Distribution Graph

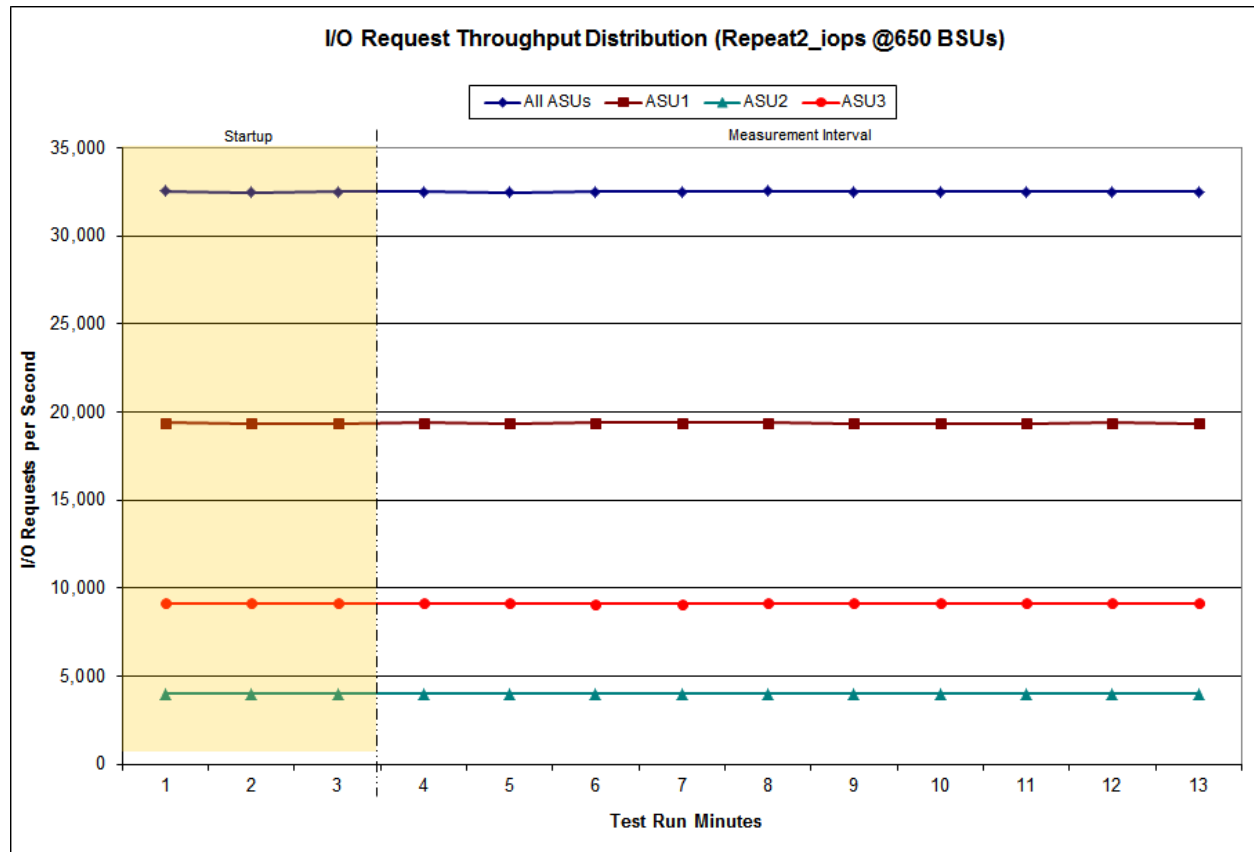

Repeatability 2 IOPS –Average Response Time (ms) Distribution Data

650 BSUs	Start	Stop	Interval	Duration
Start-Up/Ramp-Up	20:28:23	20:31:24	0-2	0:03:01
Measurement Interval	20:31:24	20:41:24	3-12	0:10:00
60 second intervals	All ASUs	ASU1	ASU2	ASU3
0	14.75	13.91	15.27	16.31
1	24.92	21.87	24.58	31.55
2	22.65	20.40	22.93	27.30
3	18.11	17.23	19.50	19.37
4	22.45	20.19	22.69	27.12
5	25.72	22.12	24.80	33.80
6	23.52	21.11	23.78	28.53
7	22.77	21.21	23.59	25.71
8	19.60	19.09	21.27	19.96
9	23.43	21.23	23.78	27.94
10	20.71	19.61	21.98	22.48
11	23.26	21.54	24.10	26.53
12	22.52	21.15	23.68	24.92
Average	22.21	20.45	22.92	25.64

Repeatability 2 IOPS –Average Response Time (ms) Distribution Graph

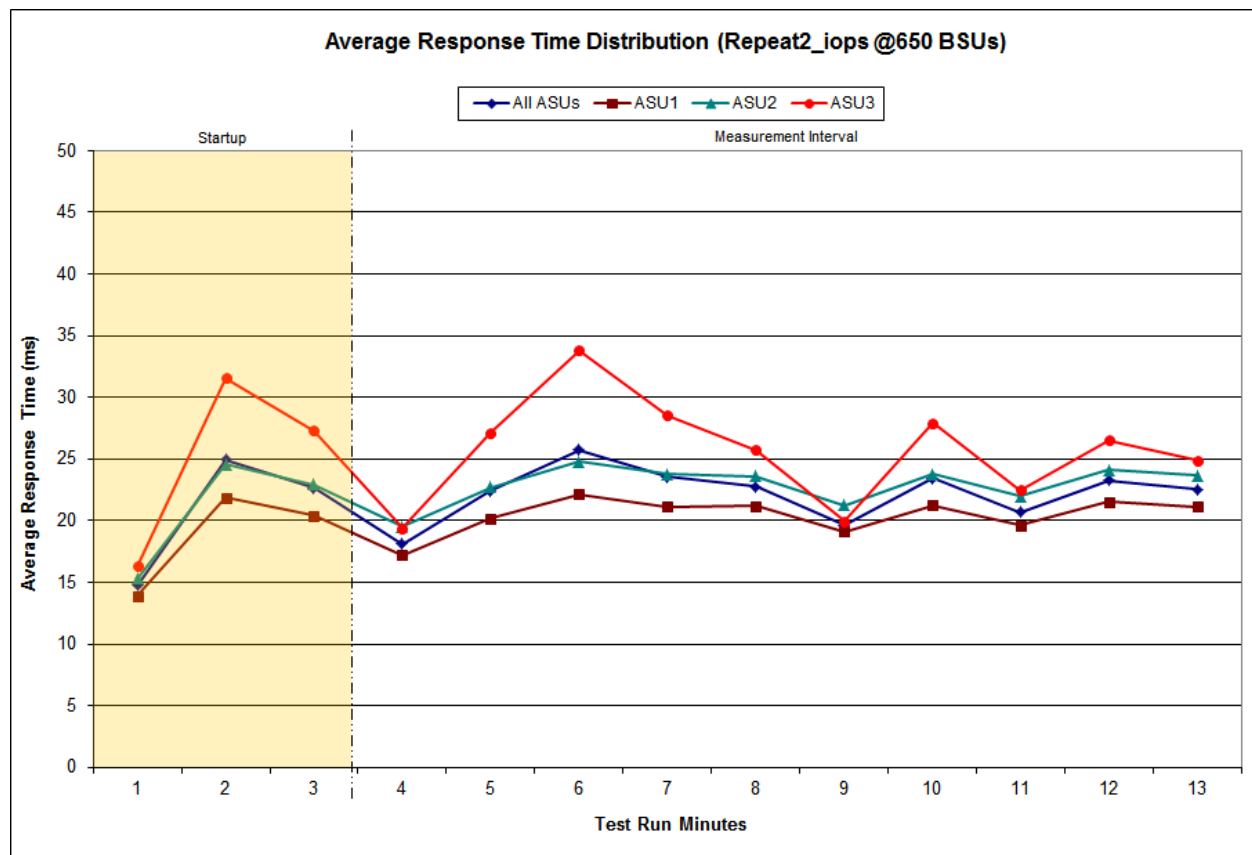

Repeatability 1 (LRT)
Measured Intensity Multiplier and Coefficient of Variation

Clause 3.4.3

IM – Intensity Multiplier: The ratio of I/Os for each I/O stream relative to the total I/Os for all I/O streams (ASU1-1 – ASU3-1) as required by the benchmark specification.

Clauses 5.1.10 and 5.3.15.2

MIM – Measured Intensity Multiplier: The Measured Intensity Multiplier represents the ratio of measured I/Os for each I/O stream relative to the total I/Os measured for all I/O streams (ASU1-1 – ASU3-1). This value may differ from the corresponding Expected Intensity Multiplier by no more than 5%.

Clause 5.3.15.3

COV – Coefficient of Variation: This measure of variation for the Measured Intensity Multiplier cannot exceed 0.2.

	ASU1-1	ASU1-2	ASU1-3	ASU1-4	ASU2-1	ASU2-2	ASU2-3	ASU3-1
IM	0.0350	0.2810	0.0700	0.2100	0.0180	0.0700	0.0350	0.2810
MIM	0.0350	0.2807	0.0700	0.2103	0.0180	0.0703	0.0349	0.2807
COV	0.009	0.004	0.009	0.006	0.012	0.005	0.012	0.003

Repeatability 1 (IOPS)
Measured Intensity Multiplier and Coefficient of Variation

	ASU1-1	ASU1-2	ASU1-3	ASU1-4	ASU2-1	ASU2-2	ASU2-3	ASU3-1
IM	0.0350	0.2810	0.0700	0.2100	0.0180	0.0700	0.0350	0.2810
MIM	0.0350	0.2809	0.0700	0.2101	0.0180	0.0701	0.0350	0.2810
COV	0.003	0.001	0.002	0.001	0.003	0.003	0.004	0.001

Repeatability 2 (LRT)
Measured Intensity Multiplier and Coefficient of Variation

	ASU1-1	ASU1-2	ASU1-3	ASU1-4	ASU2-1	ASU2-2	ASU2-3	ASU3-1
IM	0.0350	0.2810	0.0700	0.2100	0.0180	0.0700	0.0350	0.2810
MIM	0.0351	0.2811	0.0700	0.2102	0.0180	0.0698	0.0349	0.2808
COV	0.015	0.003	0.008	0.004	0.012	0.010	0.012	0.004

Repeatability 2 (IOPS)
Measured Intensity Multiplier and Coefficient of Variation

	ASU1-1	ASU1-2	ASU1-3	ASU1-4	ASU2-1	ASU2-2	ASU2-3	ASU3-1
<i>IM</i>	<i>0.0350</i>	<i>0.2810</i>	<i>0.0700</i>	<i>0.2100</i>	<i>0.0180</i>	<i>0.0700</i>	<i>0.0350</i>	<i>0.2810</i>
MIM	0.0350	0.2810	0.0701	0.2098	0.0180	0.0700	0.0350	0.2810
COV	0.003	0.001	0.003	0.001	0.006	0.003	0.003	0.001

Data Persistence Test

Clause 6

The Data Persistence Test demonstrates the Tested Storage Configuration (TSC):

- *Is capable of maintain data integrity across a power cycle.*
- *Ensures the transfer of data between Logical Volumes and host systems occurs without corruption or loss.*

The SPC-1 Workload Generator will write 16 block I/O requests at random over the total Addressable Storage Capacity of the TSC for ten (10) minutes at a minimum of 25% of the load used to generate the SPC-1 IOPS™ primary metric. The bit pattern selected to be written to each block as well as the address of the block will be retained in a log file.

The Tested Storage Configuration (TSC) will be shutdown and restarted using a power off/power on cycle at the end of the above sequence of write operations. In addition, any caches employing battery backup must be flushed/emptied.

The SPC-1 Workload Generator will then use the above log file to verify each block written contains the correct bit pattern.

Clause 9.4.3.8

The following content shall appear in this section of the FDR:

1. *A listing or screen image of all input parameters supplied to the Workload Generator.*
2. *For the successful Data Persistence Test Run, a table illustrating key results. The content, appearance, and format of this table are specified in Table 9-12. Information displayed in this table shall be obtained from the Test Run Results File referenced below in #3.*
3. *For the successful Data Persistence Test Run, the human readable Test Run Results file produced by the Workload Generator (may be contained in an appendix).*

SPC-1 Workload Generator Input Parameters

The SPC-1 Workload Generator input parameters for the Sustainability, IOPS, Response Time Ramp, Repeatability, and Persistence Test Runs are documented in [Appendix E: SPC-1 Workload Generator Input Parameters](#) on Page [73](#).

Data Persistence Test Results File

A link to each test result file generated from each Data Persistence Test is listed below.

[Persistence 1 Test Results File](#)

[Persistence 2 Test Results File](#)

Data Persistence Test Results

Data Persistence Test Results	
Data Persistence Test Run Number: 1	
Total Number of Logical Blocks Written	77,704,880
Total Number of Logical Blocks Verified	66,433,984
Total Number of Logical Blocks that Failed Verification	0
Time Duration for Writing Test Logical Blocks	10 minutes
Size in bytes of each Logical Block	512
Number of Failed I/O Requests in the process of the Test	0

In some cases the same address was the target of multiple writes, which resulted in more Logical Blocks Written than Logical Blocks Verified. In the case of multiple writes to the same address, the pattern written and verified must be associated with the last write to that address.

PRICED STORAGE CONFIGURATION AVAILABILITY DATE

Clause 9.4.3.9

The committed delivery data for general availability (Availability Date) of all products that comprise the Priced Storage Configuration must be reported. When the Priced Storage Configuration includes products or components with different availability dates, the reported Availability Date for the Priced Storage Configuration must be the date at which all components are committed to be available.

The IBM Storwize® V3700 as documented in this Full Disclosure Report is currently available for customer purchase and shipment.

PRICING INFORMATION

Clause 9.4.3.3.6

The Executive Summary shall contain a pricing spreadsheet as documented in Clause 8.3.1.

Pricing information may be found in the Priced Storage Configuration Pricing section on page 16.

TESTED STORAGE CONFIGURATION (TSC) AND PRICED STORAGE CONFIGURATION DIFFERENCES

Clause 9.4.3.3.8

The Executive Summary shall contain a list of all differences between the Tested Storage Configuration (TSC) and the Priced Storage Configuration.

A list of all differences between the Tested Storage Configuration (TSC) and Priced Storage Configuration may be found in the Executive Summary portion of this document on page 16.

ANOMALIES OR IRREGULARITIES

Clause 9.4.3.10

The FDR shall include a clear and complete description of any anomalies or irregularities encountered in the course of executing the SPC-1 benchmark that may in any way call into question the accuracy, verifiability, or authenticity of information published in this FDR.

There were no anomalies or irregularities encountered during the SPC-1 Remote Audit of the IBM Storwize® V3700.

APPENDIX A: SPC-1 GLOSSARY

“Decimal” (*powers of ten*) Measurement Units

In the storage industry, the terms “kilo”, “mega”, “giga”, “tera”, “peta”, and “exa” are commonly used prefixes for computing performance and capacity. For the purposes of the SPC workload definitions, all of the following terms are defined in “powers of ten” measurement units.

A kilobyte (KB) is equal to 1,000 (10^3) bytes.

A megabyte (MB) is equal to 1,000,000 (10^6) bytes.

A gigabyte (GB) is equal to 1,000,000,000 (10^9) bytes.

A terabyte (TB) is equal to 1,000,000,000,000 (10^{12}) bytes.

A petabyte (PB) is equal to 1,000,000,000,000,000 (10^{15}) bytes

An exabyte (EB) is equal to 1,000,000,000,000,000,000 (10^{18}) bytes

“Binary” (*powers of two*) Measurement Units

The sizes reported by many operating system components use “powers of two” measurement units rather than “power of ten” units. The following standardized definitions and terms are also valid and may be used in this document.

A kibibyte (KiB) is equal to 1,024 (2^{10}) bytes.

A mebibyte (MiB) is equal to 1,048,576 (2^{20}) bytes.

A gibibyte (GiB) is equal to 1,073,741,824 (2^{30}) bytes.

A tebibyte (TiB) is equal to 1,099,511,627,776 (2^{40}) bytes.

A pebibyte (PiB) is equal to 1,125,899,906,842,624 (2^{50}) bytes.

An exbibyte (EiB) is equal to 1,152,921,504,606,846,967 (2^{60}) bytes.

SPC-1 Data Repository Definitions

Total ASU Capacity: The total storage capacity read and written in the course of executing the SPC-1 benchmark.

Application Storage Unit (ASU): The logical interface between the storage and SPC-1 Workload Generator. The three ASUs (Data, User, and Log) are typically implemented on one or more Logical Volume.

Logical Volume: The division of Addressable Storage Capacity into individually addressable logical units of storage used in the SPC-1 benchmark. Each Logical Volume is implemented as a single, contiguous address space.

Addressable Storage Capacity: The total storage (sum of Logical Volumes) that can be read and written by application programs such as the SPC-1 Workload Generator.

Configured Storage Capacity: This capacity includes the Addressable Storage Capacity and any other storage (parity disks, hot spares, etc.) necessary to implement the Addressable Storage Capacity.

Physical Storage Capacity: The formatted capacity of all storage devices physically present in the Tested Storage Configuration (TSC).

Data Protection Overhead: The storage capacity required to implement the selected level of data protection.

Required Storage: The amount of Configured Storage Capacity required to implement the Addressable Storage Configuration, excluding the storage required for the three ASUs.

Global Storage Overhead: The amount of Physical Storage Capacity that is required for storage subsystem use and unavailable for use by application programs.

Total Unused Storage: The amount of storage capacity available for use by application programs but not included in the Total ASU Capacity.

SPC-1 Data Protection Levels

Protected 1: The single point of failure of any *storage device* in the configuration will not result in permanent loss of access to or integrity of the SPC-1 Data Repository.

Protected 2: The single point of failure of any *component* in the configuration will not result in permanent loss of access to or integrity of the SPC-1 Data Repository.

SPC-1 Test Execution Definitions

Average Response Time: The sum of the Response Times for all Measured I/O Requests divided by the total number of Measured I/O Requests.

Completed I/O Request: An I/O Request with a Start Time and a Completion Time (see “I/O Completion Types” below).

Completion Time: The time recorded by the Workload Generator when an I/O Request is satisfied by the TSC as signaled by System Software.

Data Rate: The data transferred in all Measured I/O Requests in an SPC-1 Test Run divided by the length of the Test Run in seconds.

Expected I/O Count: For any given I/O Stream and Test Phase, the product of 50 times the BSU level, the duration of the Test Phase in seconds, and the Intensity Multiplier for that I/O Stream.

Failed I/O Request: Any I/O Request issued by the Workload Generator that could not be completed or was signaled as failed by System Software. A Failed I/O Request has no Completion Time (see “I/O Completion Types” below).

I/O Request Throughput: The total number of Measured I/O requests in an SPC-1 Test Run divided by the duration of the Measurement Interval in seconds.

In-Flight I/O Request: An I/O Request issued by the I/O Command Generator to the TSC that has a recorded Start Time, but does not complete within the Measurement Interval (see “I/O Completion Types” below).

Measured I/O Request: A Completed I/O Request with a Completion Time occurring within the Measurement Interval (see “I/O Completion Types” below).

Measured Intensity Multiplier: The percentage of all Measured I/O Requests that were issued by a given I/O Stream.

Measurement Interval: The finite and contiguous time period, after the TSC has reached Steady State, when data is collected by a Test Sponsor to generate an SPC-1 test result or support an SPC-1 test result.

Ramp-Up: The time required for the Benchmark Configuration (BC) to produce Steady State throughput after the Workload Generator begins submitting I/O Requests to the TSC for execution.

Ramp-Down: The time required for the BC to complete all I/O Requests issued by the Workload Generator. The Ramp-Down period begins when the Workload Generator ceases to issue new I/O Requests to the TSC.

Response Time: The Response Time of a Measured I/O Request is its Completion Time minus its Start Time.

Start Time: The time recorded by the Workload Generator when an I/O Request is submitted, by the Workload Generator, to the System Software for execution on the Tested Storage Configuration (TSC).

Start-Up: The period that begins after the Workload Generator starts to submit I/O requests to the TSC and ends at the beginning of the Measurement Interval.

Shut-Down: The period between the end of the Measurement Interval and the time when all I/O Requests issued by the Workload Generator have completed or failed.

Steady State: The consistent and sustainable throughput of the TSC. During this period the load presented to the TSC by the Workload Generator is constant.

Test: A collection of Test Phases and or Test Runs sharing a common objective.

Test Run: The execution of SPC-1 for the purpose of producing or supporting an SPC-1 test result. SPC-1 Test Runs may have a finite and measured Ramp-Up period, Start-Up period, Shut-Down period, and Ramp-Down period as illustrated in the “SPC-1 Test Run Components” below. All SPC-1 Test Runs shall have a Steady State period and a Measurement Interval.

Test Phase: A collection of one or more SPC-1 Test Runs sharing a common objective and intended to be run in a specific sequence.

I/O Completion Types

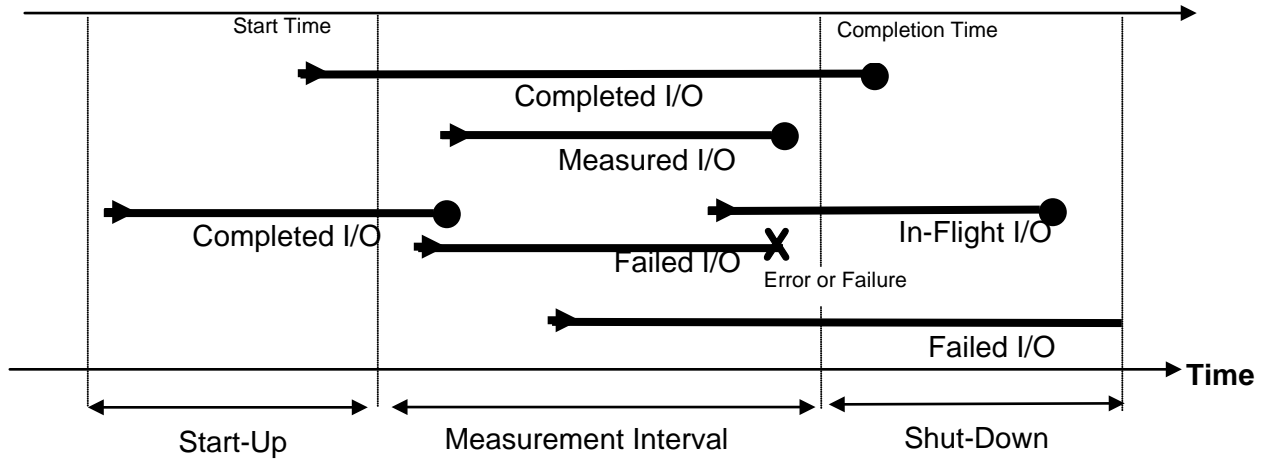

SPC-1 Test Run Components

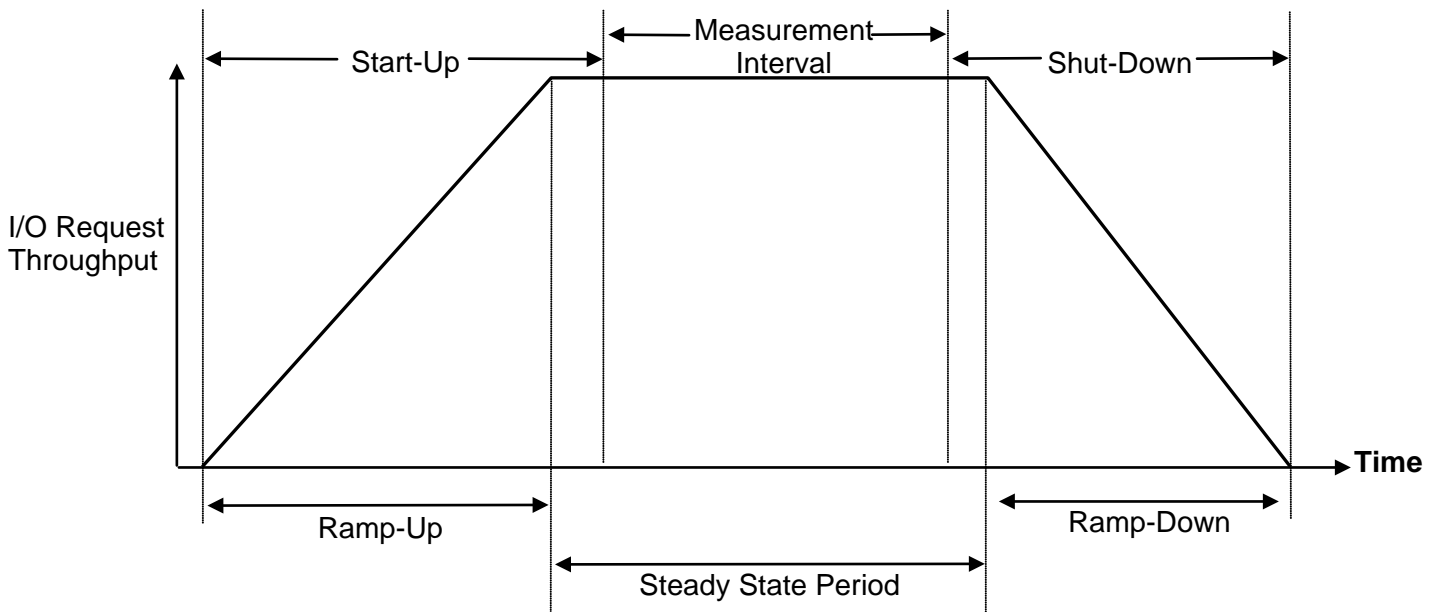

APPENDIX B: CUSTOMER TUNABLE PARAMETERS AND OPTIONS

There were no customer tunable parameter or options changed from their default values.

APPENDIX C: TESTED STORAGE CONFIGURATION (TSC) CREATION

Storwize V3700 Configuration

The **cyg** scripts require the installation of Cygwin (www.cygwin.com) and are executed as standard shell scripts in a Cygwin command window on one of the Host Systems.

Each **cyg** script was submitted to the Storwize V7000 using PuTTY (www.putty.org), a well known freeware package. In each of those scripts, **\$plink** is substituted with the command **plink name_of_cluster**, where **name_of_cluster** is a saved network location for the TSC.

Each script referenced in this section appears below in the [Referenced Scripts](#) section of this appendix.

Creat RAID10 Arrays and MDisks

The [step1_mkranks.cyg](#) script organizes the disks into RAID10 arrays (*8 disks per array*), which results in 17 MDisks as seen by the V3700.

Create the VDisks

The [step2_mkvdisks.cyg](#) script causes the MDisks to be presented 1 to 1 as 15 VDisks.

Create the Host Paths

The [step3_mkhost.cyg](#) script create a list of host paths.

Assign Primary and Alternate Host Paths

The [step4_mapfcs.cyg](#) script maps each Vdisk to all available FC paths.

Windows Configuration

In Windows, multipath management was provided by SDDDSM, which comes as the driver for the Storwize V3700.

The [mkdiskpart.cyg](#) script will create the [dpmake.bat](#) script for use by the Windows Diskpart command line utility. The [mkdiskpart.cyg](#) script is invoked as follows:

```
mkdiskpart.cyg 1 15 dpmake.bat
```

The [dpmake.bat](#) script is executed in a Windows command line window to complete the following:

- Scan the Windows “physical disks”.
- Create 18 logical volumes with a stripe size of 36,864 MiB across “physical disks” 1-15 for a total capacity of 552,960 MiB per logical volume.
- Assign drive letter E-V to the striped logical volumes, which comprise the three SPC-1 ASUs.

Referenced Scripts

step1_mkrancks.cyg

```
#!/usr/bin/bash
# run in cygwin command line
# Creates 15 RAID-10 arrays of 8 disks each, all in the same SAS chain.
$plink svctask mkmdiskgrp -name thebiggroup -ext 256
$plink svctask mkmdiskgrp -name thebiggroup -ext 1024 -warning 80%
drives=`$plink svcinfo lsdrive -nohdr | awk '{ print $1 }'`
for d in $drives
do
svctask chdrive -use candidate $d
done
c_enc=( -1 -1 -1 -1 -1 )
n=0
for cnum in 1
do
chain=`$plink svcinfo lssasfabric -nohdr -delim : | \
grep "^[^:]*:[^:]*:[^:]*:[^:]*:[^:]*:[^:]*:$cnum:[^:]*:[^:]*:[^:]*:[^:]*:node1" | cut
-d: -f1 - | sort -n -`
for i in $chain
do
c_enc[$n]=$i
let n="n+1"
done
done
arrcount=0
s0=0
e0=0
while [[ $arrcount -le 15 ]]
do
devlist=`for d in 0 1 2 3 4 5 6 7; do let s="(s0+d)%24 + 1"; let e="e0+(s0+d)/24";
\
$plink svcinfo lsencllosureslot -slot $s ${c_enc[$e]} 2>/dev/null | \
awk '(FNR==8) { print $2 }'; done | awk -v ORS="" '{ print (FNR==1?"":"") $1 }'
\
echo $devlist
$plink svctask mkarray -level raid10 -drive $devlist -sparegoal 0 thebiggroup
let e0="e0+(s0+8)/24"
let s0="(s0+8)%24"
let arrcount="arrcount+1"
done
```

step2_mkvdisk.cyg

```
#!/usr/bin/bash
#execute in cygwin command line
i=0
while [[ $i -le 14]]
do
let node="1 + (i%2)"
iogrp=0
let cap=660
$plink svctask mkvdisk -vtype seq -mdisk md$i \
-size $cap -unit gb -mdiskgrp thebiggroup -iogrp 0 \
-name vdisk$i -node $node
let i="i+1"
done
```

step3_mkhost.cyg

```
$plink svctask mkhost -force -name fcs0 -hbawwpn 21000024FF41FFFA
$plink svctask mkhost -force -name fcs1 -hbawwpn 21000024FF41EE85
$plink svctask mkhost -force -name fcs2 -hbawwpn 21000024FF42005E
$plink svctask mkhost -force -name fcs3 -hbawwpn 21000024FF41EB4F
$plink svctask mkhost -force -name fcs4 -hbawwpn 21000024FF41FFFB
$plink svctask mkhost -force -name fcs5 -hbawwpn 21000024FF41EE84
$plink svctask mkhost -force -name fcs6 -hbawwpn 21000024FF42005F
$plink svctask mkhost -force -name fcs7 -hbawwpn 21000024FF41EB4E
```

step4_mapfcs.cyg

```
i=0
while [[ $i -le 14 ]]
do
    $plink svctask mkvdiskhostmap -force -host fcs0 $i
    $plink svctask mkvdiskhostmap -force -host fcs1 $i
    $plink svctask mkvdiskhostmap -force -host fcs2 $i
    $plink svctask mkvdiskhostmap -force -host fcs3 $i
    $plink svctask mkvdiskhostmap -force -host fcs4 $i
    $plink svctask mkvdiskhostmap -force -host fcs5 $i
    $plink svctask mkvdiskhostmap -force -host fcs6 $i
    $plink svctask mkvdiskhostmap -force -host fcs7 $i
    let i="i+1"
done
```

mkdiskpart.cyg

```
#!/usr/bin/bash
# run in cygwin command line
#Makes batch input to create 18 striped volumes from specified disks with the
diskpart utility.
if [[ $# -lt 3 ]]
then
    echo "usage: mkdiskpart N1 N2 <name of batch file>."
    return
fi
letter=( E F G H I J K L M N O P Q R S T U V )
echo "rescan" > $3
i=$1
while [[ $i -le $2 ]]
do
    echo "select disk $i" >> $3
    echo "clean" >> $3
    echo "convert dynamic" >> $3
    if [[ $i -eq $1 ]]
    then
        disklist=$i
    else
        disklist=$disklist,$i
    fi
    let i="i+1"
done
echo "select volume 0" >> $3
i=0
while [[ $i -le 17 ]]
do
    echo "create volume stripe size=36864 disk=$disklist" >> $3
    echo "assign letter ${letter[$i]}" >> $3
    let i="i+1"
done
echo "exit" >> $3
```

dpmake.bat

```
rescan
select disk 1
clean
convert dynamic
select disk 2
clean
convert dynamic
select disk 3
clean
convert dynamic
select disk 4
clean
convert dynamic
select disk 5
clean
convert dynamic
select disk 6
clean
convert dynamic
select disk 7
clean
convert dynamic
select disk 8
clean
convert dynamic
select disk 9
clean
convert dynamic
select disk 10
clean
convert dynamic
select disk 11
clean
convert dynamic
select disk 12
clean
convert dynamic
select disk 13
clean
convert dynamic
select disk 14
clean
convert dynamic
select disk 15
clean
convert dynamic
create volume stripe size=36864 disk=1,2,3,4,5,6,7,8,9,10,11,12,13,14,15
assign letter E
create volume stripe size=36864 disk=1,2,3,4,5,6,7,8,9,10,11,12,13,14,15
assign letter F
create volume stripe size=36864 disk=1,2,3,4,5,6,7,8,9,10,11,12,13,14,15
assign letter G
create volume stripe size=36864 disk=1,2,3,4,5,6,7,8,9,10,11,12,13,14,15
assign letter H
create volume stripe size=36864 disk=1,2,3,4,5,6,7,8,9,10,11,12,13,14,15
assign letter I
create volume stripe size=36864 disk=1,2,3,4,5,6,7,8,9,10,11,12,13,14,15
assign letter J
create volume stripe size=36864 disk=1,2,3,4,5,6,7,8,9,10,11,12,13,14,15
assign letter K
create volume stripe size=36864 disk=1,2,3,4,5,6,7,8,9,10,11,12,13,14,15
```

```
assign letter L
create volume stripe size=36864 disk=1,2,3,4,5,6,7,8,9,10,11,12,13,14,15
assign letter M
create volume stripe size=36864 disk=1,2,3,4,5,6,7,8,9,10,11,12,13,14,15
assign letter N
create volume stripe size=36864 disk=1,2,3,4,5,6,7,8,9,10,11,12,13,14,15
assign letter O
create volume stripe size=36864 disk=1,2,3,4,5,6,7,8,9,10,11,12,13,14,15
assign letter P
create volume stripe size=36864 disk=1,2,3,4,5,6,7,8,9,10,11,12,13,14,15
assign letter Q
create volume stripe size=36864 disk=1,2,3,4,5,6,7,8,9,10,11,12,13,14,15
assign letter R
create volume stripe size=36864 disk=1,2,3,4,5,6,7,8,9,10,11,12,13,14,15
assign letter S
create volume stripe size=36864 disk=1,2,3,4,5,6,7,8,9,10,11,12,13,14,15
assign letter T
create volume stripe size=36864 disk=1,2,3,4,5,6,7,8,9,10,11,12,13,14,15
assign letter U
create volume stripe size=36864 disk=1,2,3,4,5,6,7,8,9,10,11,12,13,14,15
assign letter V
exit
```

APPENDIX D: SPC-1 WORKLOAD GENERATOR STORAGE COMMANDS AND PARAMETERS

ASU Pre-Fill

The content of command and parameter file, used in this benchmark to execute the required ASU pre-fill, is listed below.

```
*
* This will produce a random data pattern of the entire LBA range using LSFR 32bit
*
compratio=1
sd=default,threads=1

sd=sd1,size=579820584960,lun=\\.E:
sd=sd2,size=579820584960,lun=\\.F:
sd=sd3,size=579820584960,lun=\\.G:
sd=sd4,size=579820584960,lun=\\.H:
sd=sd5,size=579820584960,lun=\\.I:
sd=sd6,size=579820584960,lun=\\.J:
sd=sd7,size=579820584960,lun=\\.K:
sd=sd8,size=579820584960,lun=\\.L:
sd=sd9,size=579820584960,lun=\\.M:
sd=sd10,size=579820584960,lun=\\.N:
sd=sd11,size=579820584960,lun=\\.O:
sd=sd12,size=579820584960,lun=\\.P:
sd=sd13,size=579820584960,lun=\\.Q:
sd=sd14,size=579820584960,lun=\\.R:
sd=sd15,size=579820584960,lun=\\.S:
sd=sd16,size=579820584960,lun=\\.T:
sd=sd17,size=579820584960,lun=\\.U:
sd=sd18,size=579820584960,lun=\\.V:

wd=default,rdpct=0,seek=-1,xfersize=256K
wd=wd1,sd=sd1
wd=wd2,sd=sd2
wd=wd3,sd=sd3
wd=wd4,sd=sd4
wd=wd5,sd=sd5
wd=wd6,sd=sd6
wd=wd7,sd=sd7
wd=wd8,sd=sd8
wd=wd9,sd=sd9
wd=wd10,sd=sd10
wd=wd11,sd=sd11
wd=wd12,sd=sd12
wd=wd13,sd=sd13
wd=wd14,sd=sd14
wd=wd15,sd=sd15
wd=wd16,sd=sd16
wd=wd17,sd=sd17
wd=wd18,sd=sd18

*=====
* Use 20 hours as a maximum elapsed time,
* which should ensure the entire LBA range
* will be written before the time elapses
*=====
*
*
```

```
rd=FILLIT,wd=wd*,iorate=max,elapsed=72000,interval=10
*
* The above "elapsed=72000" may have to be increased to ensure that the utility will
reach
* the end of the LUN ("seek=-1") prior to the end of the specified elapsed time
```

Primary Metrics, Repeatability and SPC-1 Persistence Tests

The content of SPC-1 Workload Generator command and parameter file used in this benchmark to execute the Primary Metrics (*Sustainability Test Phase, IOPS Test Phase, and Response Time Ramp Test Phase*), Repeatability (*Repeatability Test Phase 1 and Repeatability Test Phase 2*), and SPC-1 Persistence Tests is listed below.

```
sd=default,size=579820584960
sd=asu1_1,lun=\\.E:
sd=asu1_2,lun=\\.F:
sd=asu1_3,lun=\\.G:
sd=asu1_4,lun=\\.H:
sd=asu1_5,lun=\\.I:
sd=asu1_6,lun=\\.J:
sd=asu1_7,lun=\\.K:
sd=asu1_8,lun=\\.L:
sd=asu2_1,lun=\\.M:
sd=asu2_2,lun=\\.N:
sd=asu2_3,lun=\\.O:
sd=asu2_4,lun=\\.P:
sd=asu2_5,lun=\\.Q:
sd=asu2_6,lun=\\.R:
sd=asu2_7,lun=\\.S:
sd=asu2_8,lun=\\.T:
sd=asu3_1,size=515396075520,lun=\\.U:
sd=asu3_2,size=515396075520,lun=\\.V:
```

APPENDIX E: SPC-1 WORKLOAD GENERATOR INPUT PARAMETERS

The **spcstart1.bat** script is executed to capture TSC profile listing required for a Remote Audit, invoke the **asufill.bat** script to execute the required ASU pre-fill and finally invoke the **spcstart2.bat** script to execute the Primary Metrics Test (*Sustainability Test Phase, IOPS Test Phase, and Response Time Ramp Test Phase*), the Repeatability Test (*Repeatability Test Phase 1 and Repeatability Test Phase 2*), and SPC-1 Persistence Test Run 1 in an uninterrupted sequence.

spcstart1.bat

```
echo "creating list of drives in system" >> caplist.txt
plink -pw l0destone root@perf8 svcinfo lsdrive >> caplist.txt
echo "creating list of mdisks in system" >> caplist.txt
plink -pw l0destone root@perf8 svcinfo lsmdisk >> caplist.txt
echo "creating list of Vdisks in system" >> caplist.txt
plink -pw l0destone root@perf8 svcinfo lsvdisk >> caplist.txt
echo "creating list of nodes in system" >> caplist.txt
plink -pw l0destone root@perf8 svcinfo lsnode >> caplist.txt
echo "creating detailed view of nodes 1 in system" >> caplist.txt
plink -pw l0destone root@perf8 svcinfo lsnode 1 >> caplist.txt
echo "creating detailed view of nodes 2 in system" >> caplist.txt
plink -pw l0destone root@perf8 svcinfo lsnode 2 >> caplist.txt
echo "creating detailed view of fc/fcoe/sas fabric"
plink -pw l0destone root@perf8 svcinfo lsfabric >> caplist.txt
plink -pw l0destone root@perf8 svcinfo lssasfabric >> caplist.txt
echo "creating list of drives and partitions from host perspective" >> caplist.txt
diskpart /s hostcapcmd >> caplist.txt
call asufill.bat
call spcstart2.bat
```

asufill.bat

```
echo "ASU prefill started....." >> caplist.txt
vdbench -f c:\vdbench503\fill.cfg -o prefilloutput.out
echo "ASU prefill complete....." >> caplist.txt
```

spcstart2.bat

```
java -Xmx640m metrics -b 650 -s 180 -t 28800
java -Xmx640m repeat1 -b 650 -s 180
java -Xmx640m repeat2 -b 650 -s 180
java -Xmx1280m -Xms1280m persist1 -b 650
```

SPC-1 Persistence Test Run 2

The SPC-1 Persistence Test Run 2 was started manually by executing the following command on the Host System:

java persist2