



**SPC BENCHMARK 1™  
FULL DISCLOSURE REPORT**

**HITACHI DATA SYSTEMS CORPORATION  
HITACHI UNIFIED STORAGE 150**

**SPC-1 V1.13**

**Submitted for Review: March 26, 2013**

**Submission Identifier: A00128**

**Revised: March 20, 2014**

**First Edition – March 2013**

THE INFORMATION CONTAINED IN THIS DOCUMENT IS DISTRIBUTED ON AN AS IS BASIS WITHOUT ANY WARRANTY EITHER EXPRESS OR IMPLIED. The use of this information or the implementation of any of these techniques is the customer's responsibility and depends on the customer's ability to evaluate and integrate them into the customer's operational environment. While each item has been reviewed by Hitachi Data Systems Corporation for accuracy in a specific situation, there is no guarantee that the same or similar results will be obtained elsewhere. Customers attempting to adapt these techniques to their own environment do so at their own risk.

This publication was produced in the United States. Hitachi Data Systems Corporation may not offer the products, services, or features discussed in this document in other countries, and the information is subject to change with notice. Consult your local Hitachi Data Systems Corporation representative for information on products and services available in your area.

© Copyright Hitachi Data Systems Corporation 2013. All rights reserved.

Permission is hereby granted to reproduce this document in whole or in part, provided the copyright notice as printed above is set forth in full text on the title page of each item reproduced.

**Trademarks**

SPC Benchmark-1, SPC-1, SPC-1 IOPS, SPC-1 LRT and SPC-1 Price-Performance are trademarks of the Storage Performance Council. Hitachi Data Systems, Hitachi, HDS and the Hitachi Data Systems logo are trademarks or registered trademarks of Hitachi Data Systems Corporation in the United States and other countries. All other brands, trademarks, and product names are the property of their respective owners.

## Table of Contents

<b>Audit Certification</b> .....	<b>vii</b>
<b>Audit Certification (cont.)</b> .....	<b>viii</b>
<b>Letter of Good Faith</b> .....	<b>ix</b>
<b>Executive Summary</b> .....	<b>10</b>
<b>Test Sponsor and Contact Information</b> .....	<b>10</b>
<b>Revision Information and Key Dates</b> .....	<b>10</b>
<b>Tested Storage Product (TSP) Description</b> .....	<b>10</b>
<b>Summary of Results</b> .....	<b>11</b>
<b>Storage Capacities, Relationships, and Utilization</b> .....	<b>12</b>
<b>Response Time – Throughput Curve</b> .....	<b>13</b>
<b>Response Time – Throughput Data</b> .....	<b>13</b>
<b>Priced Storage Configuration Pricing</b> .....	<b>14</b>
<b>Differences between the Tested Storage Configuration (TSC) and Priced Storage Configuration</b> .....	<b>15</b>
<b>Priced Storage Configuration Diagram</b> .....	<b>16</b>
<b>Priced Storage Configuration Components</b> .....	<b>17</b>
<b>Configuration Information</b> .....	<b>18</b>
<b>Benchmark Configuration (BC)/Tested Storage Configuration (TSC) Diagram</b> .....	<b>18</b>
<b>Storage Network Configuration</b> .....	<b>18</b>
<b>Host System(s) and Tested Storage Configuration (TSC) Table of Components</b> .....	<b>18</b>
<b>Benchmark Configuration/Tested Storage Configuration Diagram</b> .....	<b>19</b>
<b>Host System(s) and Tested Storage Configuration Components</b> .....	<b>20</b>
<b>Customer Tunable Parameters and Options</b> .....	<b>21</b>
<b>Tested Storage Configuration (TSC) Description</b> .....	<b>21</b>
<b>SPC-1 Workload Generator Storage Configuration</b> .....	<b>21</b>
<b>ASU Pre-Fill</b> .....	<b>22</b>
<b>SPC-1 Data Repository</b> .....	<b>23</b>
<b>Storage Capacities and Relationships</b> .....	<b>23</b>
SPC-1 Storage Capacities .....	<b>23</b>
<b>SPC-1 Storage Capacities and Relationships Illustration</b> .....	<b>24</b>
SPC-1 Storage Hierarchy Ratios .....	<b>24</b>
<b>Storage Capacity Utilization</b> .....	<b>25</b>
<b>Logical Volume Capacity and ASU Mapping</b> .....	<b>25</b>
<b>SPC-1 Benchmark Execution Results</b> .....	<b>26</b>
<b>SPC-1 Tests, Test Phases, and Test Runs</b> .....	<b>26</b>

<b>Primary Metrics Test – Sustainability Test Phase .....</b>	<b>27</b>
SPC-1 Workload Generator Input Parameters .....	27
Sustainability Test Results File .....	27
Sustainability – Data Rate Distribution Data (MB/second) .....	27
Sustainability – Data Rate Distribution Graph .....	28
Sustainability – I/O Request Throughput Distribution Data .....	29
Sustainability – I/O Request Throughput Distribution Graph .....	29
Sustainability – Average Response Time (ms) Distribution Data .....	30
Sustainability – Average Response Time (ms) Distribution Graph .....	30
Sustainability – Response Time Frequency Distribution Data .....	31
Sustainability – Response Time Frequency Distribution Graph .....	31
Sustainability – Measured Intensity Multiplier and Coefficient of Variation.....	32
<b>Primary Metrics Test – IOPS Test Phase .....</b>	<b>33</b>
SPC-1 Workload Generator Input Parameters .....	33
IOPS Test Results File.....	33
IOPS Test Run – I/O Request Throughput Distribution Data .....	34
IOPS Test Run – I/O Request Throughput Distribution Graph.....	34
IOPS Test Run – Average Response Time (ms) Distribution Data .....	35
IOPS Test Run – Average Response Time (ms) Distribution Graph .....	35
IOPS Test Run –Response Time Frequency Distribution Data .....	36
IOPS Test Run –Response Time Frequency Distribution Graph.....	36
IOPS Test Run – I/O Request Information.....	37
IOPS Test Run – Measured Intensity Multiplier and Coefficient of Variation.....	37
<b>Primary Metrics Test – Response Time Ramp Test Phase .....</b>	<b>38</b>
SPC-1 Workload Generator Input Parameters .....	38
Response Time Ramp Test Results File.....	38
Response Time Ramp Distribution (IOPS) Data.....	39
Response Time Ramp Distribution (IOPS) Graph .....	40
SPC-1 LRT™ Average Response Time (ms) Distribution Data.....	41
SPC-1 LRT™ Average Response Time (ms) Distribution Graph .....	41
SPC-1 LRT™ (10%) – Measured Intensity Multiplier and Coefficient of Variation .....	42
<b>Repeatability Test .....</b>	<b>43</b>
SPC-1 Workload Generator Input Parameters .....	43
Repeatability Test Results File .....	44
Repeatability 1 LRT – I/O Request Throughput Distribution Data.....	45
Repeatability 1 LRT – I/O Request Throughput Distribution Graph .....	45
Repeatability 1 LRT –Average Response Time (ms) Distribution Data .....	46
Repeatability 1 LRT –Average Response Time (ms) Distribution Graph.....	46
Repeatability 1 IOPS – I/O Request Throughput Distribution Data .....	47

Repeatability 1 IOPS – I/O Request Throughput Distribution Graph.....	47
Repeatability 1 IOPS –Average Response Time (ms) Distribution Data.....	48
Repeatability 1 IOPS –Average Response Time (ms) Distribution Graph .....	48
Repeatability 2 LRT – I/O Request Throughput Distribution Data.....	49
Repeatability 2 LRT – I/O Request Throughput Distribution Graph .....	49
Repeatability 2 LRT –Average Response Time (ms) Distribution Data .....	50
Repeatability 2 LRT –Average Response Time (ms) Distribution Graph.....	50
Repeatability 2 IOPS – I/O Request Throughput Distribution Data .....	51
Repeatability 2 IOPS – I/O Request Throughput Distribution Graph.....	51
Repeatability 2 IOPS –Average Response Time (ms) Distribution Data.....	52
Repeatability 2 IOPS –Average Response Time (ms) Distribution Graph .....	52
Repeatability 1 (LRT) Measured Intensity Multiplier and Coefficient of Variation.....	53
Repeatability 1 (IOPS) Measured Intensity Multiplier and Coefficient of Variation ....	53
Repeatability 2 (LRT) Measured Intensity Multiplier and Coefficient of Variation .....	53
Repeatability 2 (IOPS) Measured Intensity Multiplier and Coefficient of Variation ....	54
<b>Data Persistence Test.....</b>	<b>55</b>
SPC-1 Workload Generator Input Parameters .....	55
Data Persistence Test Results File .....	55
Data Persistence Test Results.....	56
<b>Priced Storage Configuration Availability Date.....</b>	<b>57</b>
<b>Pricing Information.....</b>	<b>57</b>
<b>Tested Storage Configuration (TSC) and Priced Storage Configuration Differences.....</b>	<b>57</b>
<b>Anomalies or Irregularities .....</b>	<b>57</b>
<b>Appendix A: SPC-1 Glossary .....</b>	<b>58</b>
“Decimal” ( <i>powers of ten</i> ) Measurement Units.....	58
“Binary” ( <i>powers of two</i> ) Measurement Units.....	58
SPC-1 Data Repository Definitions.....	58
SPC-1 Data Protection Levels .....	59
SPC-1 Test Execution Definitions .....	59
I/O Completion Types.....	61
SPC-1 Test Run Components .....	61
<b>Appendix B: Customer Tunable Parameters and Options.....</b>	<b>62</b>
<b>Appendix C: Tested Storage Configuration (TSC) Creation .....</b>	<b>63</b>
1. Registration of the Unit.....	63
2. Cache Partition Configuration .....	63
3. RAID Group (RG) Creation.....	65

<b>4. Logical Unit (LU) Creation .....</b>	<b>65</b>
<b>5. Map LUs to Front-End Ports .....</b>	<b>65</b>
<b>6. Set Parameters and Options.....</b>	<b>65</b>
<b>7. Reboot the Host System.....</b>	<b>65</b>
<b>8. Prepare Windows Disks for Logical Volume Creation.....</b>	<b>65</b>
<b>9. Create Windows Striped Logical Volumes .....</b>	<b>65</b>
<b>TSC Creation/Configuration Scripts .....</b>	<b>68</b>
RG_Add.....	68
LU_Add.....	69
LU_Port_Mapping.....	72
set_monitoring.....	81
set_sysparms .....	81
<b>Appendix D: SPC-1 Workload Generator Storage Commands and Parameters .....</b>	<b>85</b>
ASU Pre-Fill.....	85
Primary Metrics and Repeatability Tests .....	86
SPC-2 Persistence Test.....	86
SPC-2 Persistence Test Run 1 ( <i>write phase</i> ).....	86
SPC-2 Persistence Test Run 2 ( <i>read phase</i> ).....	87
<b>Appendix E: SPC-1 Workload Generator Input Parameters .....</b>	<b>88</b>
ASU Pre-Fill, Primary Metrics Test, Repeatability Test and Persistence Test Run 1.....	88
prefill.bat .....	88
Persistence Test Run 2.....	89
spc2.bat .....	89
<b>Appendix F: Third-Party Quotations.....</b>	<b>90</b>
Brocade 360 FC Switch .....	90
Emulex LPE12002-E LightPulse Dual Port FC HBAs and FC Cables .....	91

## AUDIT CERTIFICATION



Mel Boksenbaum  
Hitachi Data Systems Corporation  
750 Central Expressway M/S U9922  
Santa Clara, CA 95050

December 4, 2013

The SPC Benchmark 1™ Reported Data listed below for the Hitachi Unified Storage 150 was produced in compliance with the SPC Benchmark 1™ v1.13 Onsite Audit requirements.

SPC Benchmark 1™ v1.13 Reported Data	
Tested Storage Product (TSP) Name:	
Hitachi Unified Storage 150	
Metric	Reported Result
SPC-1 IOPS™	109,986.41
SPC-1 Price-Performance	\$4.45/SPC-1 IOPS™
Total ASU Capacity	76,245,000 GB
Data Protection Level	Protected 2 (Mirroring)
Total Price (including three-year maintenance)	\$489,919.78
Currency Used	U.S. Dollars
Target Country for availability, sales and support	USA

The following SPC Benchmark 1™ Onsite Audit requirements were reviewed and found compliant with 1.13 of the SPC Benchmark 1™ specification:

- A Letter of Good Faith, signed by a senior executive.
- The following Data Repository storage items were verified by physical inspection and information supplied by Hitachi Data Systems Corporation:
  - ✓ Physical Storage Capacity and requirements.
  - ✓ Configured Storage Capacity and requirements.
  - ✓ Addressable Storage Capacity and requirements.
  - ✓ Capacity of each Logical Volume and requirements.
  - ✓ Capacity of each Application Storage Unit (ASU) and requirements.
- The total Application Storage Unit (ASU) Capacity was filled with random data, using an auditor approved tool, prior to execution of the SPC-1 Tests.

Storage Performance Council  
643 Bair Island Road, Suite 103  
Redwood City, CA 94062  
[AuditService@storageperformance.org](mailto:AuditService@storageperformance.org)  
650.556.9384

## AUDIT CERTIFICATION (CONT.)

Hitachi Unified Storage 150  
SPC-1 Audit Certification

Page 2

- An appropriate diagram of the Benchmark Configuration (BC)/Tested Storage Configuration (TSC).
- Physical verification of the components to match the above diagram.
- Listings and commands to configure the Benchmark Configuration/Tested Storage Configuration, including customer tunable parameters that were changed from default values.
- SPC-1 Workload Generator commands and parameters used for the audited SPC Test Runs.
- The following Host System requirements were verified by physical inspection and information supplied by Hitachi Data Systems Corporation:
  - ✓ The type of Host System including the number of processors and main memory.
  - ✓ The presence and version number of the SPC-1 Workload Generator on the Host System.
  - ✓ The TSC boundary within the Host System.
- The execution of each Test, Test Phase, and Test Run was observed and found compliant with all of the requirements and constraints of Clauses 4, 5, and 11 of the SPC-1 Benchmark Specification.
- The Test Results Files and resultant Summary Results Files received from Hitachi Data Systems Corporation for each of following were authentic, accurate, and compliant with all of the requirements and constraints of Clauses 4 and 5 of the SPC-1 Benchmark Specification:
  - ✓ Data Persistence Test
  - ✓ Sustainability Test Phase
  - ✓ IOPS Test Phase
  - ✓ Response Time Ramp Test Phase
  - ✓ Repeatability Test
- The Priced Storage Configuration included a second 24-port FC switch as a spare to fulfill one of the requirements for a data protection level of **Protected 2**. If that second switch was added to the Tested Storage, there would be no impact on the measured SPC-1 performance.
- The submitted pricing information met all of the requirements and constraints of Clause 8 of the SPC-1 Benchmark Specification.
- The Full Disclosure Report (FDR) met all of the requirements in Clause 9 of the SPC-1 Benchmark Specification.
- This successfully audited SPC measurement is not subject to an SPC Confidential Review.

**Audit Notes:**

There were no audit notes or exceptions.

Respectfully,

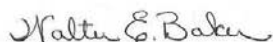

Walter E. Baker  
SPC Auditor

Storage Performance Council  
643 Bair Island Road, Suite 103  
Redwood City, CA 94062  
[AuditService@storageperformance.org](mailto:AuditService@storageperformance.org)  
650.556.9384



## LETTER OF GOOD FAITH

**HITACHI**  
Inspire the Next



Date: December 5, 2012

Mr. Walter E. Baker, SPC Auditor  
Gradient Systems, Inc.  
643 Bair Island Road, suite 103  
Redwood City, CA 94063

Subject: SPC-1 Letter of Good Faith for the Hitachi Unified Storage 150

Hitachi Data Systems is the SPC-1 Test Sponsor for the above listed product. To the best of our knowledge and belief, the required SPC-1 benchmark results and materials we have submitted for that product are complete, accurate, and in full compliance with Version 2.3.0 of the SPC-1 benchmark specification.

In addition, we have reported any items in the Benchmark Configuration and execution of the benchmark that affected the reported results even if the items are not explicitly required to be disclosed by the SPC-1 benchmark specification.

Regards,



Alan Cade  
Vice President  
Technical Operations

## EXECUTIVE SUMMARY

### Test Sponsor and Contact Information

Test Sponsor and Contact Information	
<b>Test Sponsor Primary Contact</b>	Hitachi Data Systems Corporation – <a href="http://www.hds.com">http://www.hds.com</a> David Cordero – <a href="mailto:david.cordero@hds.com">david.cordero@hds.com</a> 750 Central Expressway M/S U9922 Santa Clara, CA 95050 Phone: (617) 838-4040 FAX: (617) 838-4040
<b>Test Sponsor Alternate Contact</b>	Hitachi Data Systems Corporation – <a href="http://www.hds.com">http://www.hds.com</a> Mel Boksenbaum – <a href="mailto:mel.boksenbaum@hds.com">mel.boksenbaum@hds.com</a> 750 Central Expressway M/S U9922 Santa Clara, CA 95050 Phone: (408) 970-7922 FAX: (408) 327-3066
<b>Auditor</b>	Storage Performance Council – <a href="http://www.storageperformance.org">http://www.storageperformance.org</a> Walter E. Baker – <a href="mailto:AuditService@StoragePerformance.org">AuditService@StoragePerformance.org</a> 643 Bair Island Road, Suite 103 Redwood City, CA 94063 Phone: (650) 556-9384 FAX: (650) 556-9385

### Revision Information and Key Dates

Revision Information and Key Dates	
<b>SPC-1 Specification revision number</b>	V1.13
<b>SPC-1 Workload Generator revision number</b>	V2.3.0
<b>Date Results were first used publicly</b>	March 26, 2013
<b>Date the FDR was submitted to the SPC</b>	March 26, 2013
<b>Date revised FDR was submitted to the SPC</b> Revised pricing ( <a href="#">page 14</a> ) Revised price-related SPC-1 Reported Data ( <a href="#">page 11</a> ) New third-party quote ( <a href="#">page 90</a> )	March 20, 2014
<b>Date the Priced Storage Configuration is available for shipment to customers</b>	April 24, 2012
<b>Date the TSC completed audit certification</b>	March 19, 2013

### Tested Storage Product (TSP) Description

Hitachi redefines unified storage with Hitachi Unified Storage. With trusted Hitachi reliability, it helps you meet application availability requirements and application latency requirements with lower investment. You will be able to deploy storage for all data types and easily grow to meet expanding requirements with software features like HDT and meet service level objectives for critical business applications. It simplifies operations with easy to use management and is part of a robust portfolio of storage solutions that can be managed from a single interface for optimal management efficiency. Combine all of this with the solution portfolio for the HUS portfolio and customers will find that the HUS platform will address all of their data center needs.

## Summary of Results

SPC-1 Reported Data	
Tested Storage Product (TSP) Name: Hitachi Unified Storage 150	
Metric	Reported Result
SPC-1 IOPS™	109,986.41
SPC-1 Price-Performance™	\$4.45/SPC-1 IOPS™
Total ASU Capacity	76,245.000 GB
Data Protection Level	Protected 2 ( <i>Mirroring</i> )
Total Price	\$489,919.78
Currency Used	U.S. Dollars
Target Country for availability, sales and support	USA

SPC-1 IOPS™ represents the maximum I/O Request Throughput at the 100% load point.

SPC-1 Price-Performance™ is the ratio of **Total Price** to SPC-1 IOPS™.

**Total ASU** (Application Storage Unit) **Capacity** represents the total storage capacity available to be read and written in the course of executing the SPC-1 benchmark.

A **Data Protection Level** of **Protected 2** using *Mirroring* configures two or more identical copies of user data.

***Protected 2:** The single point of failure of any **component** in the configuration will not result in permanent loss of access to or integrity of the SPC-1 Data Repository.*

**Total Price** includes the cost of the Priced Storage Configuration plus three years of hardware maintenance and software support as detailed on page 14.

**Currency Used** is formal name for the currency used in calculating the **Total Price** and **SPC-1 Price-Performance™**. That currency may be the local currency of the **Target Country** or the currency of a difference country (*non-local currency*).

The **Target Country** is the country in which the Priced Storage Configuration is available for sale and in which the required hardware maintenance and software support is provided either directly from the Test Sponsor or indirectly via a third-party supplier.

## Storage Capacities, Relationships, and Utilization

The following diagram (*not to scale*) and table document the various storage capacities, used in this benchmark, and their relationships, as well as the storage utilization values required to be reported.

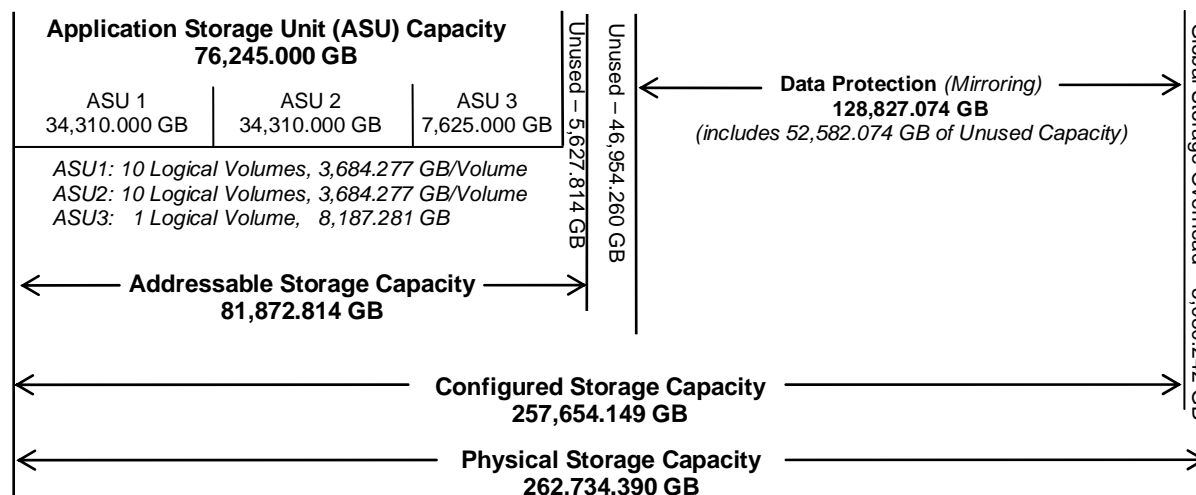

SPC-1 Storage Capacity Utilization	
Application Utilization	29.02%
Protected Application Utilization	58.04%
Unused Storage Ratio	40.03%

**Application Utilization:** Total ASU Capacity (76,245.000 GB) divided by Physical Storage Capacity (262,734.390 GB).

**Protected Application Utilization:** Total ASU Capacity (76,245.000 GB) plus total Data Protection Capacity (128,827.074 GB) minus unused Data Protection Capacity (52,582.074 GB) divided by Physical Storage Capacity (262,734.390 GB).

**Unused Storage Ratio:** Total Unused Capacity (105,164.149 GB) divided by Physical Storage Capacity (262,734.390 GB) and may not exceed 45%.

Detailed information for the various storage capacities and utilizations is available on pages 23-24.

## Response Time – Throughput Curve

The Response Time-Throughput Curve illustrates the Average Response Time (milliseconds) and I/O Request Throughput at 100%, 95%, 90%, 80%, 50%, and 10% of the workload level used to generate the SPC-1 IOPS™ metric.

The Average Response Time measured at any of the above load points cannot exceed 30 milliseconds or the benchmark measurement is invalid.

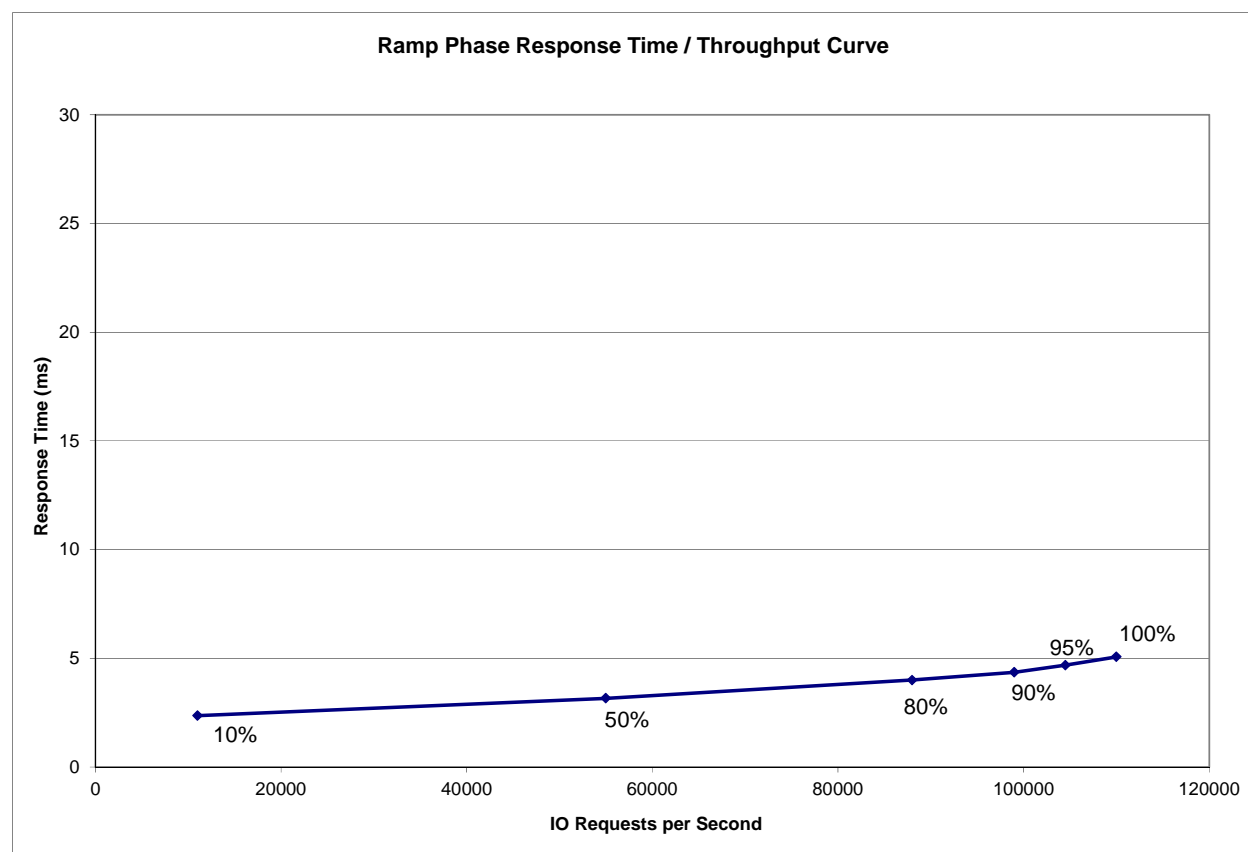

## Response Time – Throughput Data

	10% Load	50% Load	80% Load	90% Load	95% Load	100% Load
<b>I/O Request Throughput</b>	11,001.91	54,997.50	87,985.49	98,995.38	104,511.53	109,986.41
<b>Average Response Time (ms):</b>						
<b>All ASUs</b>	2.36	3.16	3.99	4.35	4.68	5.06
<b>ASU-1</b>	3.09	4.00	4.98	5.39	5.75	6.16
<b>ASU-2</b>	3.26	4.54	5.70	6.23	6.62	7.26
<b>ASU-3</b>	0.40	0.76	1.15	1.34	1.57	1.77
<b>Reads</b>	5.41	6.92	8.48	9.13	9.66	10.32
<b>Writes</b>	0.37	0.71	1.07	1.24	1.44	1.64

## Priced Storage Configuration Pricing

Product Description	Qty	Unit List Price	Product List Price
Dummy Drive for SFF (2U) Trays	16	\$0.00	\$0.00
AMS 19 in rack Americas MIN	3	\$5,427.00	\$16,281.00
HUS 300GB SAS 10K RPM HDD SFF for CBSS/DBS-Base	896	\$590.00	\$528,640.00
HUS 150 8GB Cache Module	4	\$1,930.00	\$7,720.00
HUS 150 Controller, including (2) SAS IOC processors	2	\$15,200.00	\$30,400.00
HUS Drive Box - SFF 2U x 24	38	\$5,890.00	\$223,820.00
HUS 150 4x8Gbps FC Interface Adapter	4	\$2,850.00	\$11,400.00
Hitachi Unified Storage SAS Cable 5m	16	\$760.00	\$12,160.00
HUS 150 Base Controller Box	1	\$7,600.00	\$7,600.00
50/125 LC/LC PLN 5M 2f round SB 10gig OM3	16	\$81.00	\$1,296.00
12 outlet, single phase 208V/30AMP, NEMA, 10 ft cord	12	\$735.00	\$8,820.00
<b>Hardware Components:</b>		---	<b>\$848,137.00</b>
HUS 150 Base Operating System Security Extension License	1	\$400.00	\$400.00
HUS 150 Base Operating System E Lic	1	\$9,600.00	\$9,600.00
<b>Software Components:</b>		---	<b>\$10,000.00</b>
HUS 150 Installation Support	1	\$2,750.00	\$2,750.00
HUS 150 Hardware Maintenance Support - Includes 3 years of Standard Support (24 x 7 x 4 hour response)	1	\$75,425.76	\$75,425.76
HUS 150 Storage Software Support - Includes 3 years of Standard Support	1	\$2,745.00	\$2,745.00
<b>Installation and Support:</b>		---	<b>\$80,920.76</b>
<b>Brocade 360 switch with 24 active ports, Full Fabric, 24 SWL 8Gb BR SFPs, Fixed Rack Mount</b>	2	<b>\$4,827.00</b>	<b>\$9,654.00</b>
<b>3 Year Support</b>	1	<b>\$320.00</b>	<b>\$320.00</b>
<b>13 mos Maintenance</b>	1	<b>\$107.00</b>	<b>\$107.00</b>
Fibre Channel Cables	4	\$21.25	\$85.00
EMC LightPulse Dual Port Fibre Channel Host Bus Adapter LPE12002-E	2	\$1,295.00	\$2,590.00
<b>Third Party Components:</b>		---	<b>\$12,756.00</b>

Hardware Components	\$848,137.00	54%	\$390,143.02
Software Components	\$10,000.00	39%	\$6,100.00
Installation & Support	\$80,920.76	0%	\$80,920.76
Third Party Components	\$12,756.00	0%	\$12,756.00

**Total: \$489,919.78**

The above pricing includes hardware maintenance and software support for three years, 7 days per week, 24 hours per day. The hardware maintenance and software support provides the following:

- Acknowledgement of new and existing problems with four (4) hours.
- Onsite presence of a qualified maintenance engineer or provision of a customer replaceable part within four (4) hours of the above acknowledgement for any hardware failure that results in an inoperative Price Storage Configuration that can be remedied by the repair or replacement of a Priced Storage Configuration component.

### **Differences between the Tested Storage Configuration (TSC) and Priced Storage Configuration**

A second 24-port FC switch was included in the Priced Storage Configuration as a spare to fulfill one of the requirements for a data protection level of **Protected 2**.

**Priced Storage Configuration Diagram**

**Hitachi Unified Storage 150**

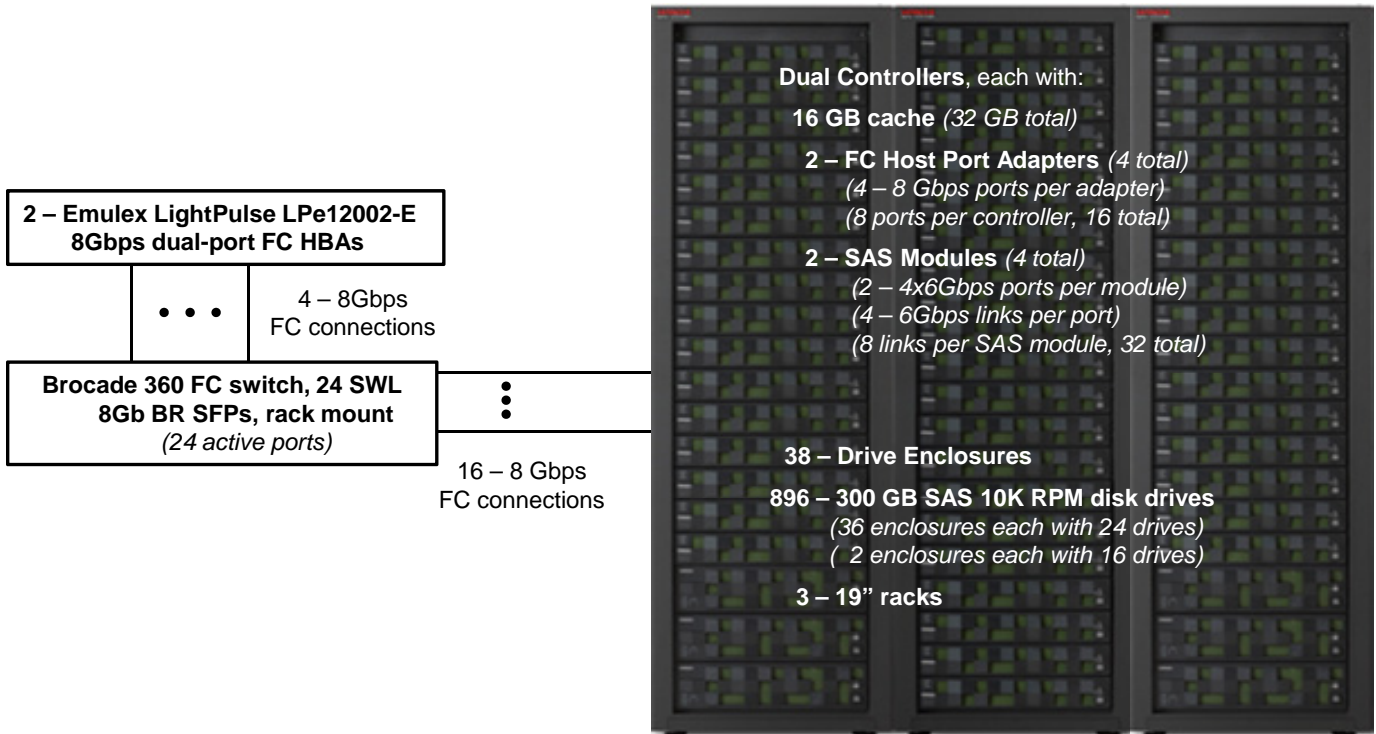

**Controllers, SAS Modules, Disk Enclosure and Disk Drive Details**

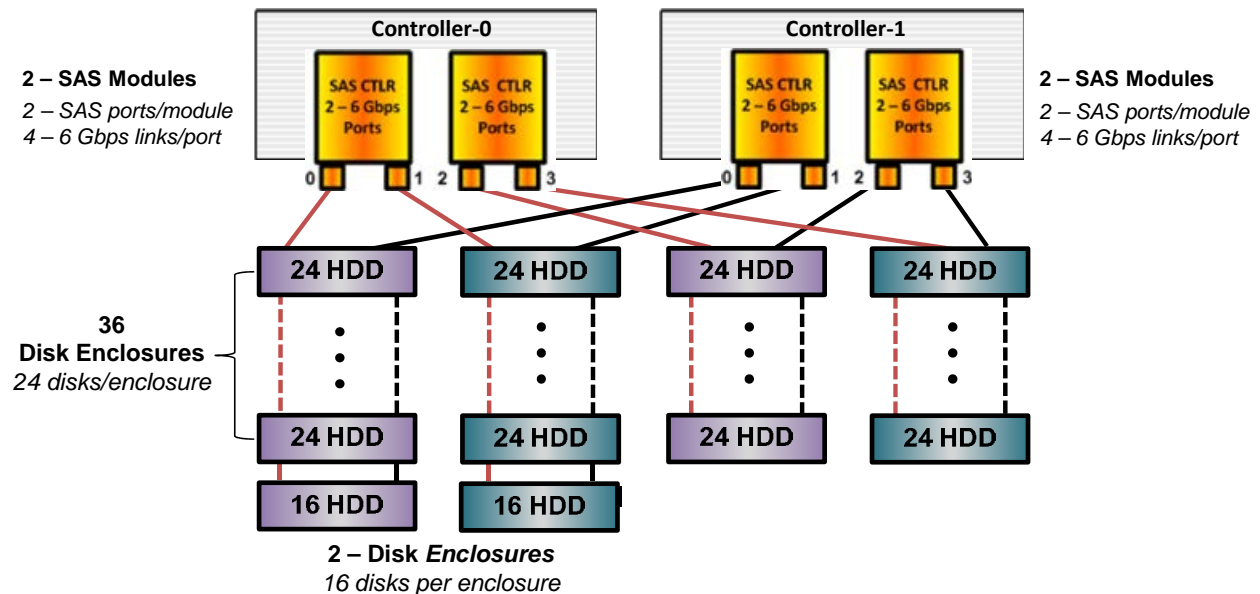



## Priced Storage Configuration Components

<b>Priced Storage Configuration:</b>
2 – Emulex LightPulse LPe12002-E 8Gbps dual port FC HBAs
2 – Brocade 360 FC switches, 24 active ports, 24 8Gb SFPs <i>(second switch used as a spare)</i>
<b>Hitachi Unified Storage 150</b> Dual Active-Active Controllers, each with 16 GB cache <i>(32 GB total)</i> 2 – FC Host Port Adapters <i>(4 total)</i> <i>(4 – 8 Gbps ports adapter)</i> <i>(8 ports per controller, 16 total, 16 used)</i> 2 – SAS Modules <i>(4 total)</i> <i>(2 – 8x6Gbps ports per module)</i> <i>(4 ports per module, 8 total, 8 used)</i> <i>(4 – 8x6Gbps links per port)</i> <i>(8 links per module, 32 total, 32 used)</i>
38 – Drive Enclosures
896 – 300 GB SAS 10K RPM disk drives <i>(36 Drive Enclosures each with 24 disk drives)</i> <i>( 2 Drive Enclosures each with 16 disk drives)</i>
3 – 19” racks, each with 4 PDUs

In each of the following sections of this document, the appropriate Full Disclosure Report requirement, from the SPC-1 benchmark specification, is stated in italics followed by the information to fulfill the stated requirement.

## **CONFIGURATION INFORMATION**

### **Benchmark Configuration (BC)/Tested Storage Configuration (TSC) Diagram**

#### **Clause 9.4.3.4.1**

*A one page Benchmark Configuration (BC)/Tested Storage Configuration (TSC) diagram shall be included in the FDR...*

The Benchmark Configuration (BC)/Tested Storage Configuration (TSC) is illustrated on page 19(*Benchmark Configuration /Tested Storage Configuration Diagram*).

### **Storage Network Configuration**

#### **Clause 9.4.3.4.1**

...

5. *If the TSC contains network storage, the diagram will include the network configuration. If a single diagram is not sufficient to illustrate both the Benchmark Configuration and network configuration in sufficient detail, the Benchmark Configuration diagram will include a high-level network illustration as shown in Figure 9-8. In that case, a separate, detailed network configuration diagram will also be included as described in Clause 9.4.3.4.2.*

#### **Clause 9.4.3.4.2**

*If a storage network was configured as a part of the Tested Storage Configuration and the Benchmark Configuration diagram described in Clause 9.4.3.4.1 contains a high-level illustration of the network configuration, the Executive Summary will contain a one page topology diagram of the storage network as illustrated in Figure 9-9.*

The storage network portion of Benchmark Configuration (BC)/Tested Storage Configuration (TSC) is illustrated on page 19 (*Benchmark Configuration /Tested Storage Configuration Diagram*).

### **Host System(s) and Tested Storage Configuration (TSC) Table of Components**

#### **Clause 9.4.3.4.3**

*The FDR will contain a table that lists the major components of each Host System and the Tested Storage Configuration (TSC). Table 9-10 specifies the content, format, and appearance of the table.*

The Host System(s) and TSC table of components may be found on page 20(*Host System(s) and Tested Storage Configuration Components*).

**Benchmark Configuration/Tested Storage Configuration Diagram**

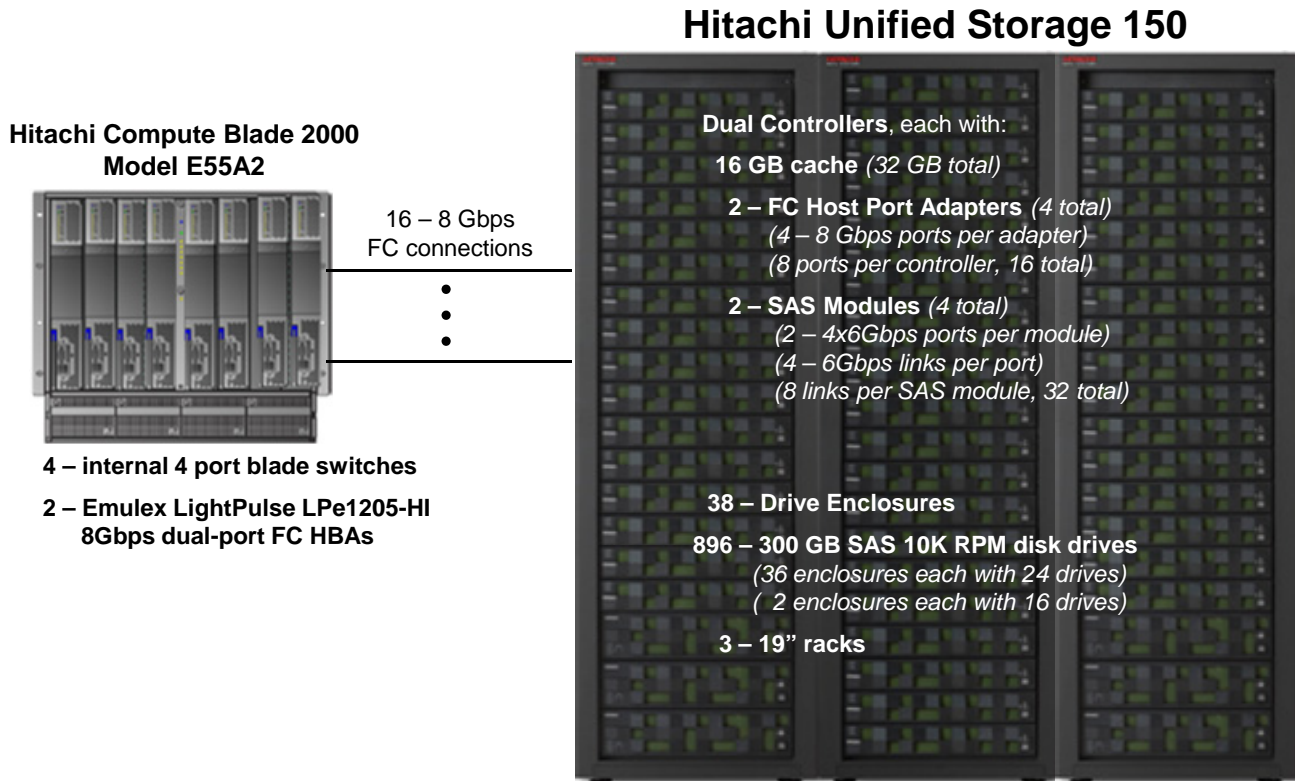

**Controllers, SAS Modules, Disk Enclosure and Disk Drive Details**

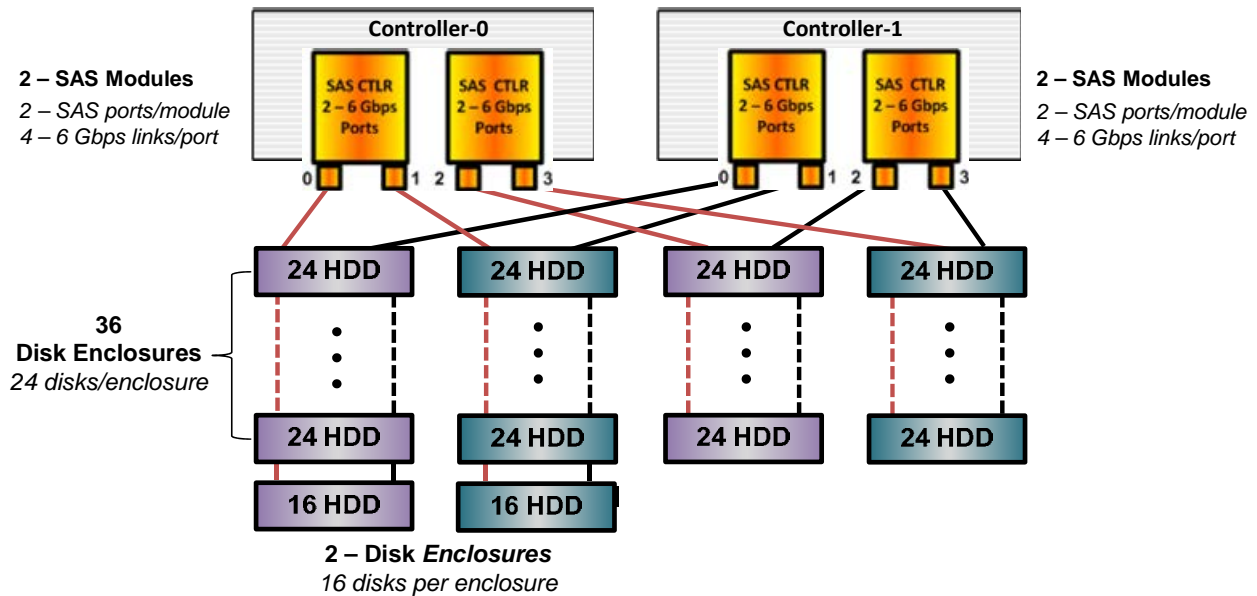

### Host System(s) and Tested Storage Configuration Components

Host System:	Tested Storage Configuration (TSC):
<b>Hitachi Compute Blade 2000 Model E55A2</b> 2 – Intel® Xeon® 5690 six core 3.46 GHz processors, 12 MB Intel® SmartCache per processor 64 GB main memory 4 – internal 4 port FC blade switches Microsoft Windows Server 2008 R2 Enterprise 6.7601, Service Pack 1 Build 7601	2 – Emulex LightPulse LPE1205-HI 8Gbps dual port FC HBAs
	<b>Hitachi Unified Storage 150</b> Dual Active-Active Controllers, each with 16 GB cache (32 GB total) 2 – FC Host Port Adapters (4 total) (4 – 8 Gbps ports adapter) (8 ports per controller, 16 total, 16 used) 2 – SAS Modules (4 total) (2 – 8x6Gbps ports per module) (4 ports per module, 8 total, 8 used) (4 – 8x6Gbps links per port) (8 links per module, 32 total, 32 used)
	38 – Drive Enclosures
	896 – 300 GB SAS 10K RPM disk drives (36 Drive Enclosures each with 24 disk drives) ( 2 Drive Enclosures each with 16 disk drives)
	3 – 19" racks, each with 4 PDUs

## Customer Tunable Parameters and Options

### Clause 9.4.3.5.1

*All Benchmark Configuration (BC) components with customer tunable parameter and options that have been altered from their default values must be listed in the FDR. The FDR entry for each of those components must include both the name of the component and the altered value of the parameter or option. If the parameter name is not self-explanatory to a knowledgeable practitioner, a brief description of the parameter's use must also be included in the FDR entry.*

“Appendix B: Customer Tunable Parameters and Options” on page 62 contains the customer tunable parameters and options that have been altered from their default values for this benchmark.

## Tested Storage Configuration (TSC) Description

### Clause 9.4.3.5.2

*The FDR must include sufficient information to recreate the logical representation of the TSC. In addition to customer tunable parameters and options (Clause 4.2.4.5.3), that information must include, at a minimum:*

- *A diagram and/or description of the following:*
  - *All physical components that comprise the TSC. Those components are also illustrated in the BC Configuration Diagram in Clause 9.2.4.4.1 and/or the Storage Network Configuration Diagram in Clause 9.2.4.4.2.*
  - *The logical representation of the TSC, configured from the above components that will be presented to the Workload Generator.*
- *Listings of scripts used to create the logical representation of the TSC.*
- *If scripts were not used, a description of the process used with sufficient detail to recreate the logical representation of the TSC.*

“Appendix C: Tested Storage Configuration (TSC) Creation” on page 63 contains the detailed information that describes how to create and configure the logical TSC.

## SPC-1 Workload Generator Storage Configuration

### Clause 9.4.3.5.3

*The FDR must include all SPC-1 Workload Generator storage configuration commands and parameters.*

The SPC-1 Workload Generator storage configuration commands and parameters for this measurement appear in “Appendix D: SPC-1 Workload Generator Storage Commands and Parameters” on page 85.

## ASU Pre-Fill

### Clause 5.3.3

*Each of the three SPC-1 ASUs (ASU-1, ASU-2 and ASU-3) is required to be completely filled with specified content prior to the execution of audited SPC-1 Tests. The content is required to consist of random data pattern such as that produced by an SPC recommended tool.*

The configuration file used to complete the required ASU pre-fill appears in “*Appendix D: SPC-1 Workload Generator Storage Commands and Parameters*” on page 85.

## **SPC-1 DATA REPOSITORY**

This portion of the Full Disclosure Report presents the detailed information that fully documents the various SPC-1 storage capacities and mappings used in the Tested Storage Configuration. “SPC-1 Data Repository Definitions” on page 58 contains definitions of terms specific to the SPC-1 Data Repository.

### **Storage Capacities and Relationships**

#### **Clause 9.4.3.6.1**

*Two tables and an illustration documenting the storage capacities and relationships of the SPC-1 Storage Hierarchy (Clause 2.1) shall be included in the FDR.*

#### **SPC-1 Storage Capacities**

The Physical Storage Capacity consisted of 262,734.390 GB distributed over 896 disk drives, each with a formatted capacity of 293.230 GB. There was 0.000 GB (0.00%) of Unused Storage within the Physical Storage Capacity. Global Storage Overhead consisted of 5,080.242 GB (1.93%) of the Physical Storage Capacity. There was 105,164.149 GB (40.82%) of Unused Storage within the Configured Storage Capacity. The Total ASU Capacity utilized 93.13% of the Addressable Storage Capacity resulting in 5,627.814 GB (6.87%) of Unused Storage within the Addressable Storage Capacity. The Data Protection (*Mirroring*) capacity was 128,827.074 GB of which 76,240.000 GB was utilized. The total Unused Storage capacity was 105.164.149 GB.

*Note: The configured Storage Devices may include additional storage capacity reserved for system overhead, which is not accessible for application use. That storage capacity may not be included in the value presented for Physical Storage Capacity.*

<b>SPC-1 Storage Capacities</b>		
<b>Storage Hierarchy Component</b>	<b>Units</b>	<b>Capacity</b>
Total ASU Capacity	Gigabytes (GB)	76,245.000
Addressable Storage Capacity	Gigabytes (GB)	81,872.814
Configured Storage Capacity	Gigabytes (GB)	257,654.149
Physical Storage Capacity	Gigabytes (GB)	262,734.390
Data Protection ( <i>Mirroring</i> )	Gigabytes (GB)	128,827.074
Required Storage	Gigabytes (GB)	0.000
Global Storage Overhead	Gigabytes (GB)	5,080.242
Total Unused Storage	Gigabytes (GB)	105,164.149

### SPC-1 Storage Capacities and Relationships Illustration

The various storage capacities configured in the benchmark result are illustrated below (*not to scale*).

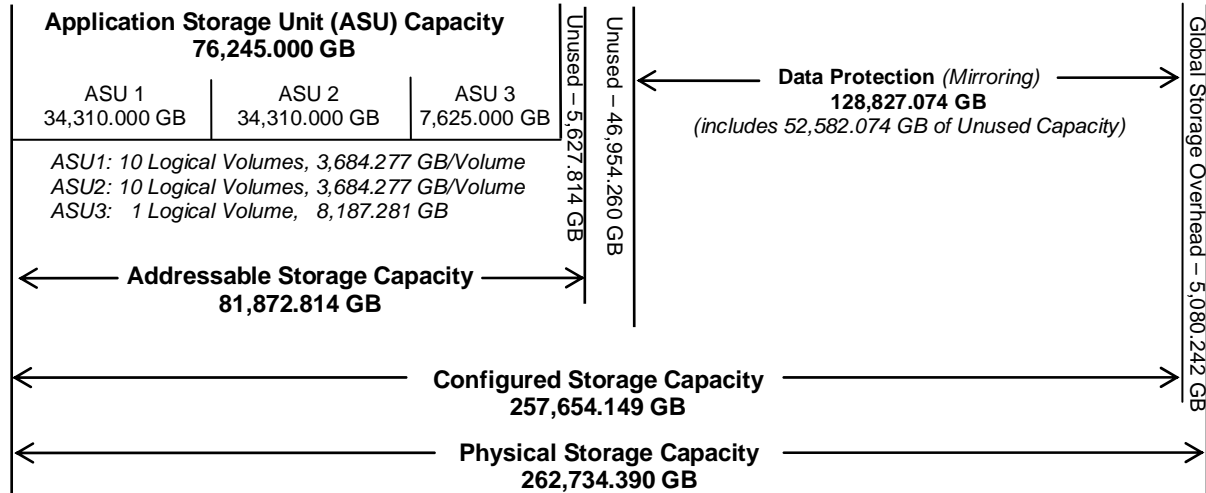

### SPC-1 Storage Hierarchy Ratios

	Addressable Storage Capacity	Configured Storage Capacity	Physical Storage Capacity
<b>Total ASU Capacity</b>	93.13%	29.59%	29.02%
<b>Required for Data Protection (Mirroring)</b>		50.00%	49.03%
<b>Addressable Storage Capacity</b>		31.78%	31.16%
<b>Required Storage</b>		0.00%	0.00%
<b>Configured Storage Capacity</b>			98.07%
<b>Global Storage Overhead</b>			1.93%
<b>Unused Storage:</b>			
<b>Addressable</b>	6.87%		
<b>Configured</b>		40.82%	
<b>Physical</b>			0.00%



## Storage Capacity Utilization

### Clause 9.4.3.6.2

The FDR will include a table illustrating the storage capacity utilization values defined for Application Utilization (Clause 2.8.1), Protected Application Utilization (Clause 2.8.2), and Unused Storage Ratio (Clause 2.8.3).

### Clause 2.8.1

Application Utilization is defined as Total ASU Capacity divided by Physical Storage Capacity.

### Clause 2.8.2

Protected Application Utilization is defined as (Total ASU Capacity plus total Data Protection Capacity minus unused Data Protection Capacity) divided by Physical Storage Capacity.

### Clause 2.8.3

Unused Storage Ratio is defined as Total Unused Capacity divided by Physical Storage Capacity and may not exceed 45%.

SPC-1 Storage Capacity Utilization	
Application Utilization	29.02%
Protected Application Utilization	58.04%
Unused Storage Ratio	40.03%

## Logical Volume Capacity and ASU Mapping

### Clause 9.4.3.6.3

A table illustrating the capacity of each ASU and the mapping of Logical Volumes to ASUs shall be provided in the FDR. ... Logical Volumes shall be sequenced in the table from top to bottom per its position in the contiguous address space of each ASU. The capacity of each Logical Volume shall be stated. ... In conjunction with this table, the Test Sponsor shall provide a complete description of the type of data protection (see Clause 2.4.5) used on each Logical Volume.

Logical Volume Capacity and Mapping		
ASU-1 (34,310.000 GB)	ASU-2 (34,310.000 GB)	ASU-3 (7,625.000 GB)
10 Logical Volumes 3,684.277 GB per Logical Volume (3,431.000 GB used per Logical Volume)	10 Logical Volumes 3,684.277 GB per Logical Volume (3,431.000 GB used per Logical Volume)	1 Logical Volume 8,187.281 GB per Logical Volume (7,625.000 GB used per Logical Volume)

The Data Protection Level used for all Logical Volumes was [Protected 2](#) using *Mirroring* as described on page 11. See “ASU Configuration” in the [IOPS Test Results File](#) for more detailed configuration information.

## **SPC-1 BENCHMARK EXECUTION RESULTS**

This portion of the Full Disclosure Report documents the results of the various SPC-1 Tests, Test Phases, and Test Runs. An [SPC-1 glossary](#) on page 58 contains definitions of terms specific to the SPC-1 Tests, Test Phases, and Test Runs.

### *Clause 5.4.3*

*The Tests must be executed in the following sequence: Primary Metrics, Repeatability, and Data Persistence. That required sequence must be uninterrupted from the start of Primary Metrics to the completion of Persistence Test Run 1. Uninterrupted means the Benchmark Configuration shall not be power cycled, restarted, disturbed, altered, or adjusted during the above measurement sequence. If the required sequence is interrupted other than for the Host System/TSC power cycle between the two Persistence Test Runs, the measurement is invalid.*

## **SPC-1 Tests, Test Phases, and Test Runs**

The SPC-1 benchmark consists of the following Tests, Test Phases, and Test Runs:

- **Primary Metrics Test**
  - Sustainability Test Phase and Test Run
  - IOPS Test Phase and Test Run
  - Response Time Ramp Test Phase
    - 95% of IOPS Test Run
    - 90% of IOPS Test Run
    - 80% of IOPS Test Run
    - 50% of IOPS Test Run
    - 10% of IOPS Test Run (LRT)
- **Repeatability Test**
  - Repeatability Test Phase 1
    - 10% of IOPS Test Run (LRT)
    - IOPS Test Run
  - Repeatability Test Phase 2
    - 10% of IOPS Test Run (LRT)
    - IOPS Test Run
- **Data Persistence Test**
  - Data Persistence Test Run 1
  - Data Persistence Test Run 2

Each Test is an atomic unit that must be executed from start to finish before any other Test, Test Phase, or Test Run may be executed.

The results from each Test, Test Phase, and Test Run are listed below along with a more detailed explanation of each component.

## Primary Metrics Test – Sustainability Test Phase

### Clause 5.4.4.1.1

*The Sustainability Test Phase has exactly one Test Run and shall demonstrate the maximum sustainable I/O Request Throughput within at least a continuous eight (8) hour Measurement Interval. This Test Phase also serves to insure that the TSC has reached Steady State prior to reporting the final maximum I/O Request Throughput result (SPC-1 IOPS™).*

### Clause 5.4.4.1.2

*The computed I/O Request Throughput of the Sustainability Test must be within 5% of the reported SPC-1 IOPS™ result.*

### Clause 5.4.4.1.4

*The Average Response Time, as defined in Clause 5.1.1, will be computed and reported for the Sustainability Test Run and cannot exceed 30 milliseconds. If the Average Response time exceeds that 30-milliseconds constraint, the measurement is invalid.*

### Clause 9.4.3.7.1

*For the Sustainability Test Phase the FDR shall contain:*

- 1. A Data Rate Distribution graph and data table.*
- 2. I/O Request Throughput Distribution graph and data table.*
- 3. A Response Time Frequency Distribution graph and table.*
- 4. An Average Response Time Distribution graph and table.*
- 5. The human readable Test Run Results File produced by the Workload Generator (may be included in an appendix).*
- 6. A listing or screen image of all input parameters supplied to the Workload Generator (may be included in an appendix).*
- 7. The Measured Intensity Multiplier for each I/O stream.*
- 8. The variability of the Measured Intensity Multiplier, as defined in Clause 5.3.13.3.*

## SPC-1 Workload Generator Input Parameters

The SPC-1 Workload Generator input parameters for the Sustainability, IOPS, Response Time Ramp, Repeatability, and Persistence Test Runs are documented in “Appendix E: SPC-1 Workload Generator Input Parameters” on Page 88.

## Sustainability Test Results File

A link to the test results file generated from the Sustainability Test Run is listed below.

[Sustainability Test Results File](#)

## Sustainability – Data Rate Distribution Data (MB/second)

The Sustainability Data Rate table of data is not embedded in this document due to its size. The table is available via the following URL:

[Sustainability Data RateTable](#)

Sustainability – Data Rate Distribution Graph

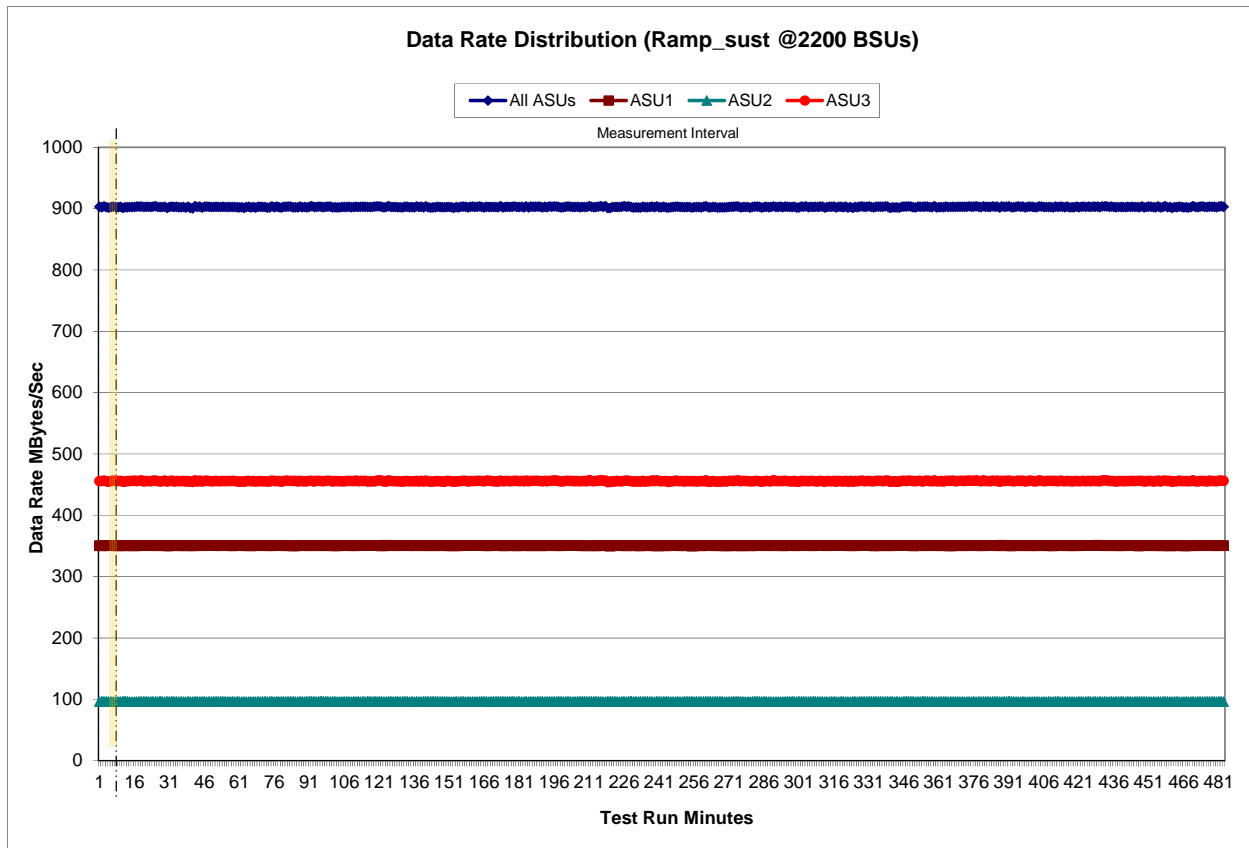

### Sustainability – I/O Request Throughput Distribution Data

The Sustainability I/O Request Throughput table of data is not embedded in this document due to its size. The table is available via the following URL:

[Sustainability I/O Request Throughput Table](#)

### Sustainability – I/O Request Throughput Distribution Graph

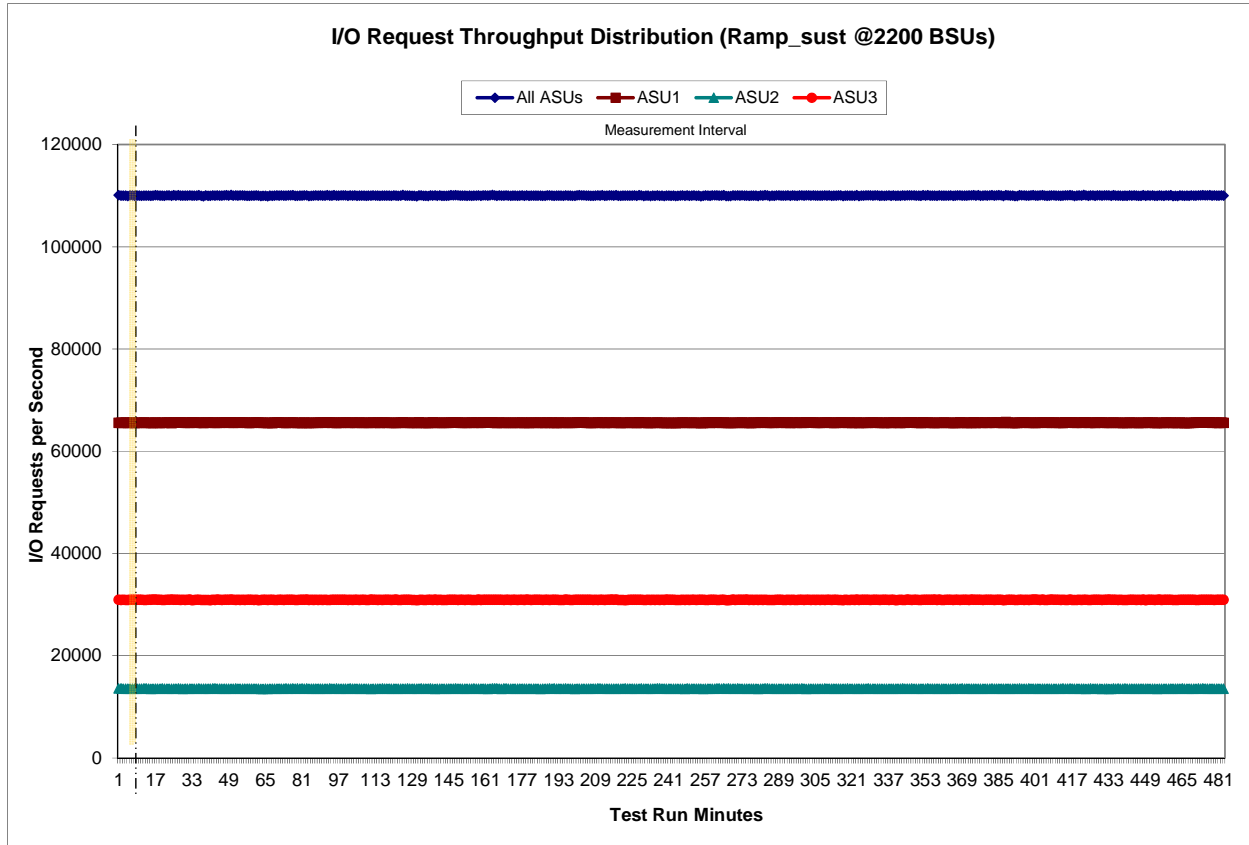

### Sustainability – Average Response Time (ms) Distribution Data

The Sustainability Average Response Time table of data is not embedded in this document due to its size. The table is available via the following URL:

[Sustainability Average Response Time Table](#)

### Sustainability – Average Response Time (ms) Distribution Graph

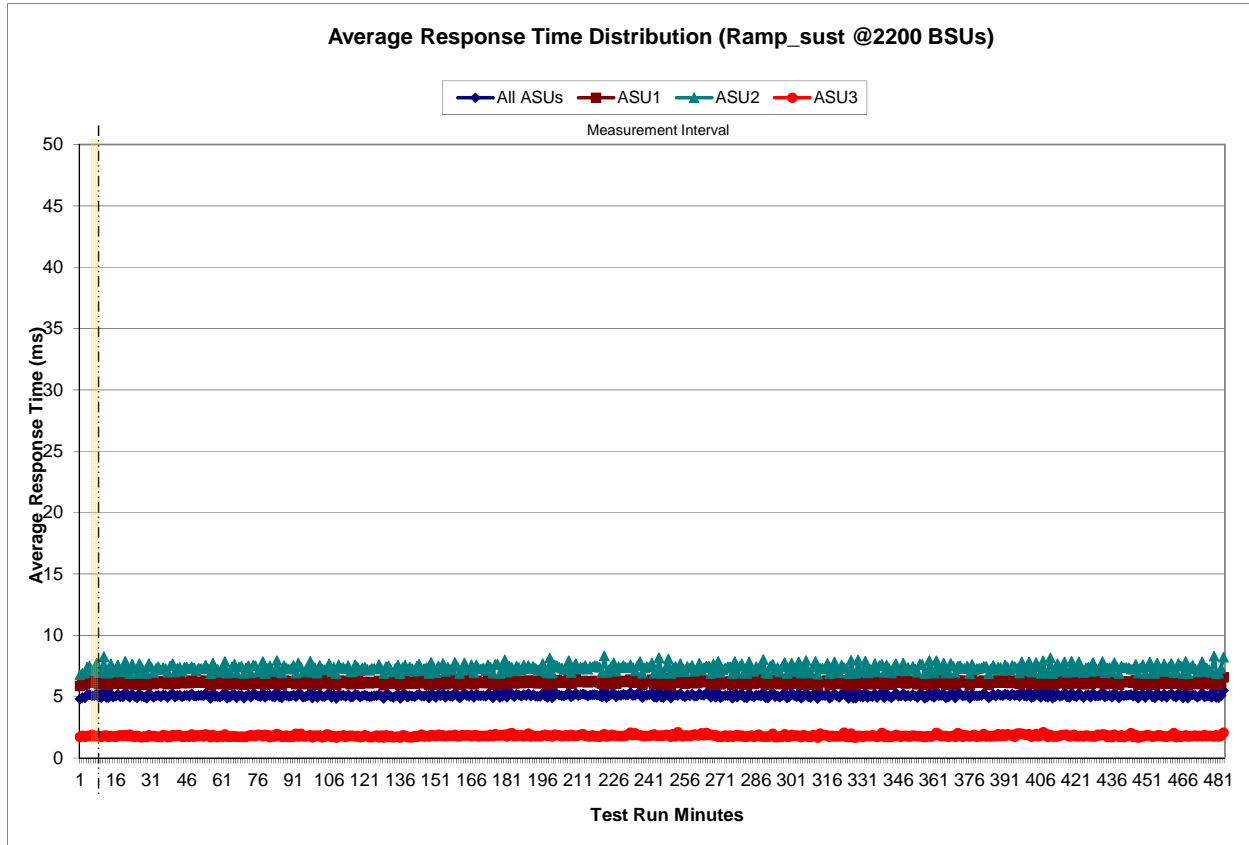

**Sustainability – Response Time Frequency Distribution Data**

Response Time (ms)	0-0.25	>0.25-0.5	>0.5-0.75	>0.75-1.0	>1.0-1.25	>1.25-1.5	>1.5-1.75	>1.75-2.0
Read	86,815	1,360,034	4,266,879	5,716,769	1,876,183	562,352	703,641	2,169,397
Write	478,003	19,959,849	167,853,399	567,229,197	488,160,923	208,825,416	163,800,403	138,221,615
All ASUs	564,818	21,319,883	172,120,278	572,945,966	490,037,106	209,387,768	164,504,044	140,391,012
ASU1	328,472	11,058,627	84,298,758	269,398,759	217,110,311	87,504,964	65,231,313	52,707,015
ASU2	64,311	2,396,806	19,288,992	62,985,560	50,864,837	20,484,647	15,196,530	11,924,703
ASU3	172,035	7,864,450	68,532,528	240,561,647	222,061,958	101,398,157	84,076,201	75,759,294
Response Time (ms)	>2.0-2.5	>2.5-3.0	>3.0-3.5	>3.5-4.0	>4.0-4.5	>4.5-5.0	>5.0-6.0	>6.0-7.0
Read	8,279,923	19,319,843	21,083,481	33,551,410	33,757,112	47,975,220	103,755,475	124,742,331
Write	62,360,076	26,602,487	10,335,780	8,853,269	5,956,052	5,427,248	7,247,585	4,646,017
All ASUs	70,639,999	45,922,330	31,419,261	42,404,679	39,713,164	53,402,468	111,003,060	129,388,348
ASU1	28,465,768	27,924,396	24,443,700	35,876,222	34,317,659	46,935,407	97,787,820	113,260,320
ASU2	4,983,612	2,602,225	1,499,865	2,072,299	2,474,593	3,850,577	9,818,525	14,048,377
ASU3	37,190,619	15,395,709	5,475,696	4,456,158	2,920,912	2,616,484	3,396,715	2,079,651
Response Time (ms)	>7.0-8.0	>8.0-9.0	>9.0-10.0	>10.0-15.0	>15.0-20.0	>20.0-25.0	>25.0-30.0	>30.0
Read	138,460,948	126,346,768	109,506,351	298,090,390	86,923,930	32,102,805	18,673,772	30,126,362
Write	2,864,497	1,906,279	1,533,196	5,872,676	5,431,721	6,085,907	2,502,835	6,329,465
All ASUs	141,325,445	128,253,047	111,039,547	303,963,066	92,355,651	38,188,712	21,176,607	36,455,827
ASU1	123,166,856	108,557,619	90,421,734	236,830,889	68,276,564	26,383,542	14,857,611	22,939,005
ASU2	16,965,628	18,954,015	20,034,524	64,850,678	21,355,160	8,473,905	4,928,672	9,533,911
ASU3	1,192,961	741,413	583,289	2,281,499	2,723,927	3,331,265	1,390,324	3,982,911

**Sustainability – Response Time Frequency Distribution Graph**

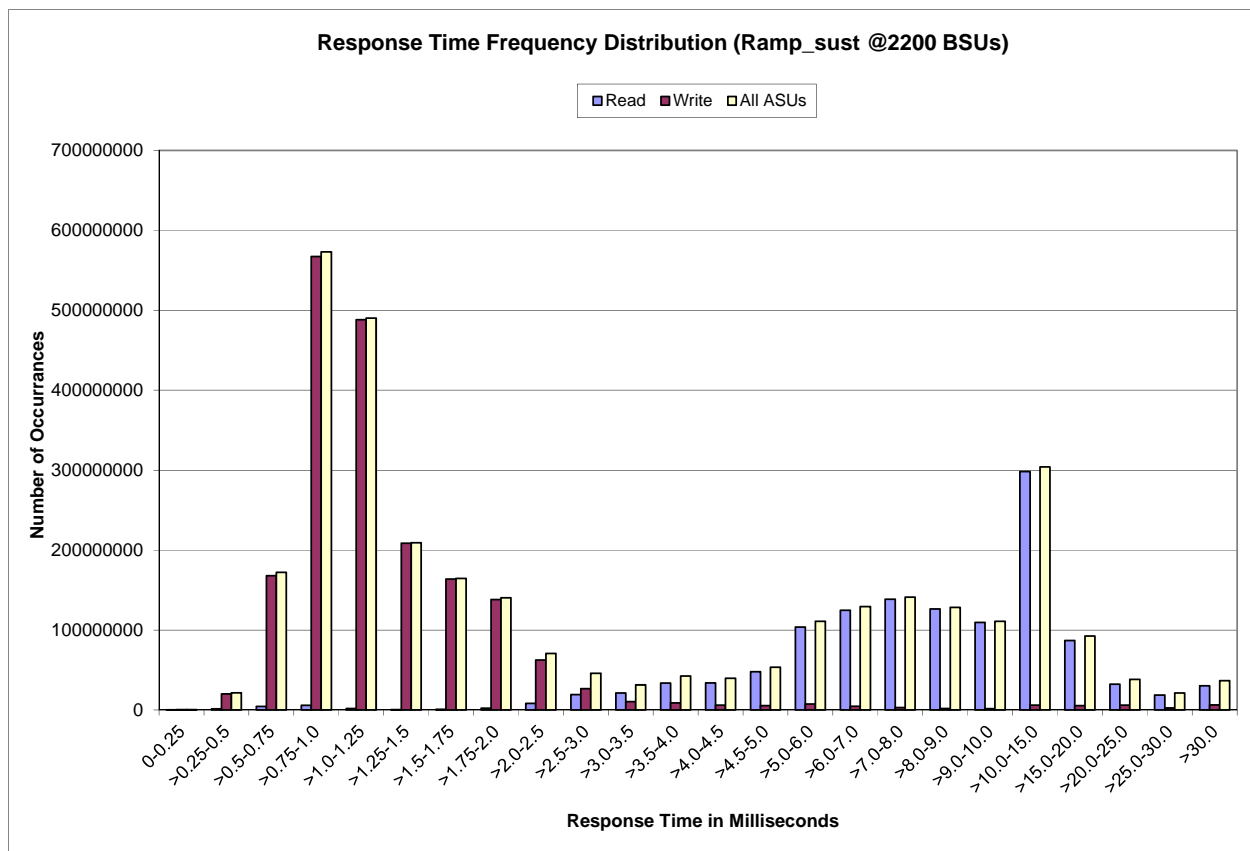

## Sustainability – Measured Intensity Multiplier and Coefficient of Variation

### Clause 3.4.3

**IM – Intensity Multiplier:** The ratio of I/Os for each I/O stream relative to the total I/Os for all I/O streams (ASU1-1 – ASU3-1) as required by the benchmark specification.

### Clauses 5.1.10 and 5.3.15.2

**MIM – Measured Intensity Multiplier:** The Measured Intensity Multiplier represents the ratio of measured I/Os for each I/O stream relative to the total I/Os measured for all I/O streams (ASU1-1 – ASU3-1). This value may differ from the corresponding Expected Intensity Multiplier by no more than 5%.

### Clause 5.3.15.3

**COV – Coefficient of Variation:** This measure of variation for the Measured Intensity Multiplier cannot exceed 0.2.

	ASU1-1	ASU1-2	ASU1-3	ASU1-4	ASU2-1	ASU2-2	ASU2-3	ASU3-1
IM	0.0350	0.2810	0.0700	0.2100	0.0180	0.0700	0.0350	0.2810
MIM	0.0350	0.2810	0.0700	0.2100	0.0180	0.0700	0.0350	0.2810
COV	0.002	0.001	0.001	0.001	0.003	0.001	0.002	0.001



## Primary Metrics Test – IOPS Test Phase

### Clause 5.4.4.2

*The IOPS Test Phase consists of one Test Run at the 100% load point with a Measurement Interval of ten (10) minutes. The IOPS Test Phase immediately follows the Sustainability Test Phase without any interruption or manual intervention.*

*The IOPS Test Run generates the SPC-1 IOPS™ primary metric, which is computed as the I/O Request Throughput for the Measurement Interval of the IOPS Test Run.*

*The Average Response Time is computed for the IOPS Test Run and cannot exceed 30 milliseconds. If the Average Response Time exceeds the 30 millisecond constraint, the measurement is invalid.*

### Clause 9.4.3.7.2

*For the IOPS Test Phase the FDR shall contain:*

- 1. I/O Request Throughput Distribution (data and graph).*
- 2. A Response Time Frequency Distribution.*
- 3. An Average Response Time Distribution.*
- 4. The human readable Test Run Results File produced by the Workload Generator.*
- 5. A listing or screen image of all input parameters supplied to the Workload Generator.*
- 6. The total number of I/O Requests completed in the Measurement Interval as well as the number of I/O Requests with a Response Time less than or equal to 30 milliseconds and the number of I/O Requests with a Response Time greater than 30 milliseconds.*

## SPC-1 Workload Generator Input Parameters

The SPC-1 Workload Generator input parameters for the Sustainability, IOPS, Response Time Ramp, Repeatability, and Persistence Test Runs are documented in “Appendix E: SPC-1 Workload Generator Input Parameters” on Page 88.

## IOPS Test Results File

A link to the test results file generated from the IOPS Test Run is listed below.

[IOPS Test Results File](#)

### IOPS Test Run – I/O Request Throughput Distribution Data

2,200 BSUs	Start	Stop	Interval	Duration
Start-Up/Ramp-Up	2:59:55	3:02:56	0-2	0:03:01
Measurement Interval	3:02:56	3:12:56	3-12	0:10:00
60 second intervals	All ASUs	ASU1	ASU2	ASU3
0	110,058.60	65,627.73	13,528.93	30,901.93
1	110,001.55	65,563.92	13,507.93	30,929.70
2	109,995.17	65,582.52	13,521.53	30,891.12
3	109,994.37	65,524.95	13,542.12	30,927.30
4	110,038.33	65,575.13	13,512.75	30,950.45
5	110,028.15	65,576.03	13,512.70	30,939.42
6	109,964.83	65,549.68	13,550.90	30,864.25
7	109,951.57	65,523.28	13,533.00	30,895.28
8	110,040.35	65,566.78	13,558.15	30,915.42
9	109,900.92	65,534.13	13,522.02	30,844.77
10	109,972.55	65,527.58	13,533.13	30,911.83
11	109,982.87	65,519.13	13,550.53	30,913.20
12	109,990.15	65,573.62	13,521.42	30,895.12
<b>Average</b>	<b>109,986.41</b>	<b>65,547.03</b>	<b>13,533.67</b>	<b>30,905.70</b>

### IOPS Test Run – I/O Request Throughput Distribution Graph

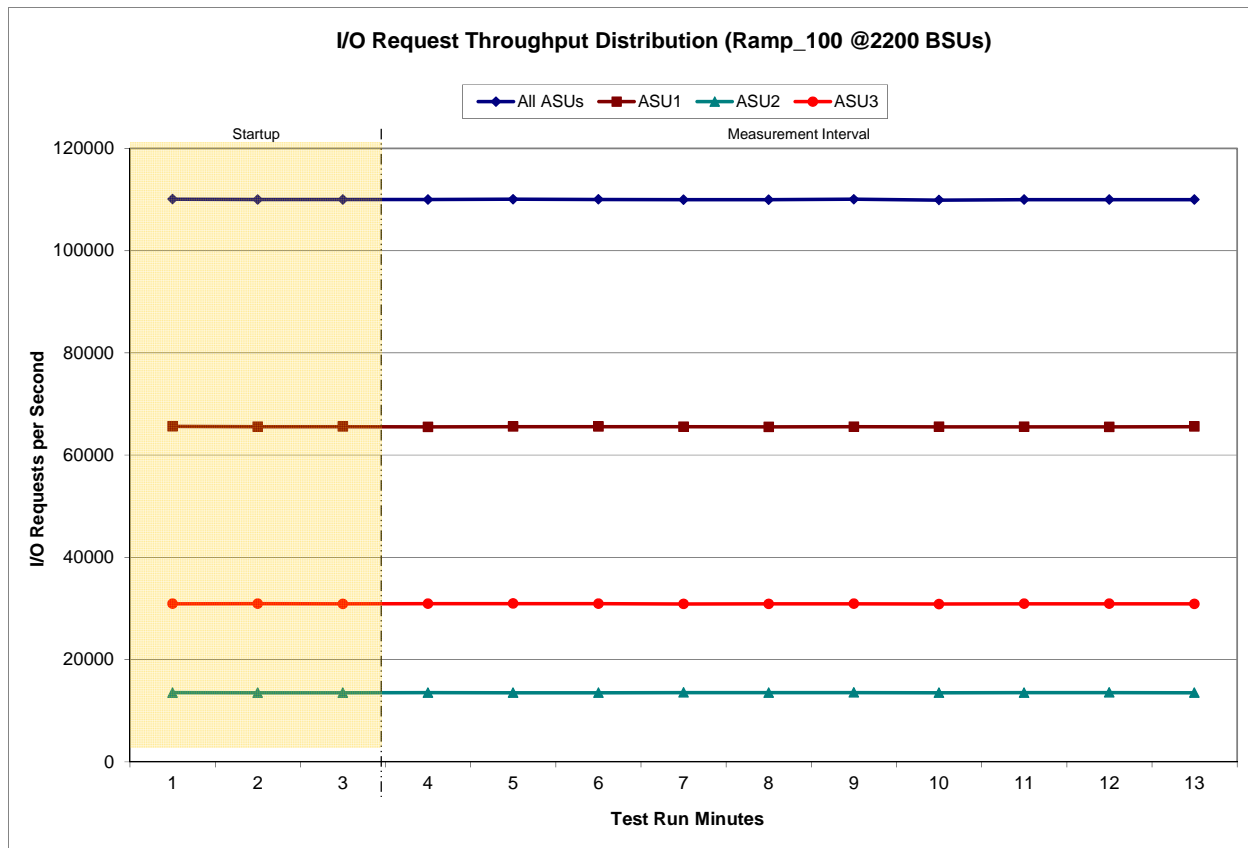

**IOPS Test Run – Average Response Time (ms) Distribution Data**

2,200 BSUs	Start	Stop	Interval	Duration
<b>Start-Up/Ramp-Up</b>	2:59:55	3:02:56	0-2	0:03:01
<b>Measurement Interval</b>	3:02:56	3:12:56	3-12	0:10:00
60 second intervals	All ASUs	ASU1	ASU2	ASU3
0	4.74	5.79	6.70	1.66
1	4.88	5.94	6.86	1.76
2	4.90	5.98	6.87	1.75
3	5.29	6.44	7.79	1.76
4	4.93	6.01	6.99	1.76
5	4.94	6.02	6.95	1.76
6	5.12	6.24	7.47	1.69
7	5.11	6.18	7.30	1.86
8	5.04	6.13	7.27	1.75
9	5.19	6.27	7.46	1.92
10	4.96	6.03	7.02	1.79
11	5.00	6.10	7.08	1.74
12	5.02	6.13	7.24	1.70
<b>Average</b>	<b>5.06</b>	<b>6.16</b>	<b>7.26</b>	<b>1.77</b>

**IOPS Test Run – Average Response Time (ms) Distribution Graph**

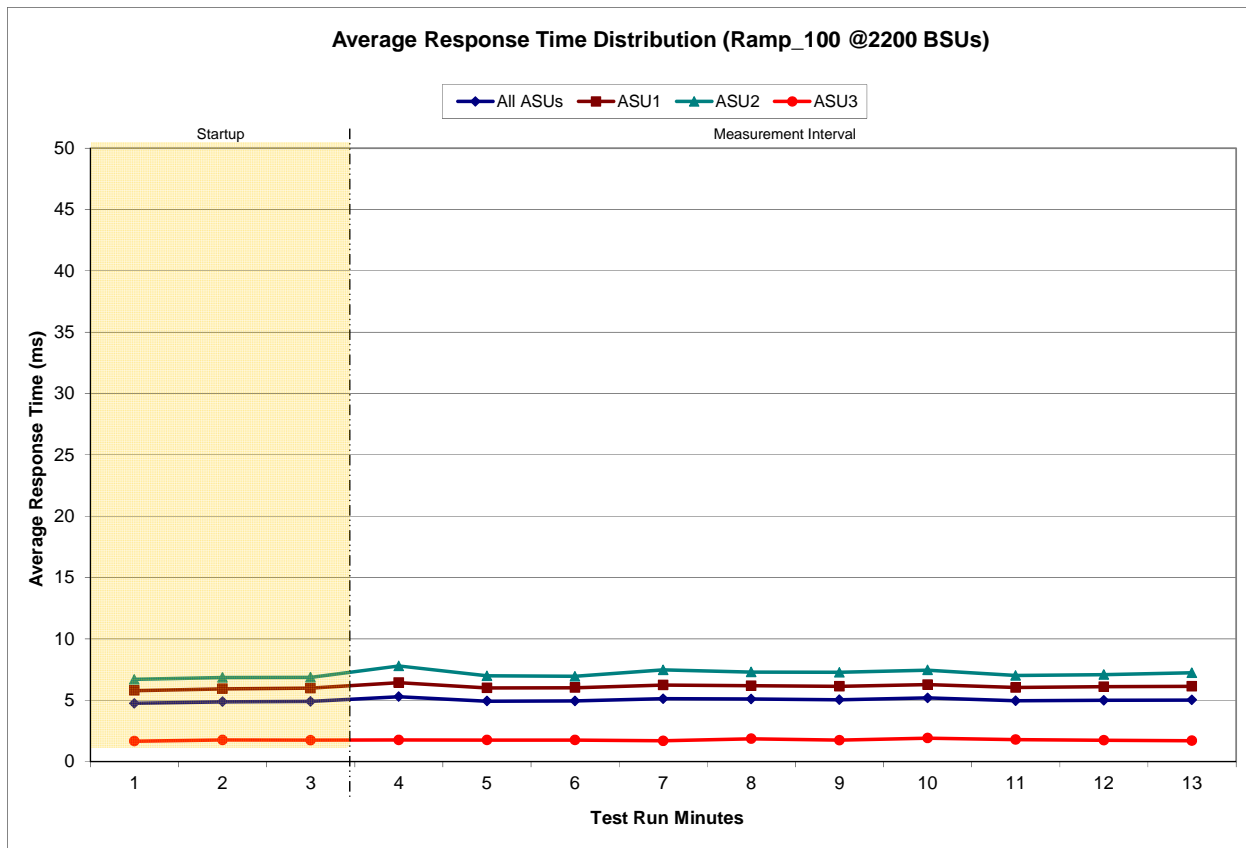

**IOPS Test Run –Response Time Frequency Distribution Data**

Response Time (ms)	0-0.25	>0.25-0.5	>0.5-0.75	>0.75-1.0	>1.0-1.25	>1.25-1.5	>1.5-1.75	>1.75-2.0
Read	1,867	29,266	91,785	124,530	40,557	11,878	14,497	44,847
Write	10,039	412,955	3,415,687	11,888,831	10,219,414	4,333,430	3,348,814	2,926,089
All ASUs	11,906	442,221	3,507,472	12,013,361	10,259,971	4,345,308	3,363,311	2,970,936
ASU1	6,992	229,667	1,719,999	5,653,777	4,546,315	1,814,958	1,331,814	1,114,727
ASU2	1,422	49,788	393,162	1,321,604	1,064,095	424,577	309,510	252,440
ASU3	3,492	162,766	1,394,311	5,037,980	4,649,561	2,105,773	1,721,987	1,603,769
Response Time (ms)	>2.0-2.5	>2.5-3.0	>3.0-3.5	>3.5-4.0	>4.0-4.5	>4.5-5.0	>5.0-6.0	>6.0-7.0
Read	170,058	398,522	437,371	696,515	702,070	998,657	2,163,135	2,599,446
Write	1,296,508	553,656	216,655	186,828	123,658	114,953	152,038	97,984
All ASUs	1,466,566	952,178	654,026	883,343	825,728	1,113,610	2,315,173	2,697,430
ASU1	590,158	577,421	507,706	745,647	713,217	976,913	2,036,534	2,358,412
ASU2	103,164	54,626	31,538	43,519	51,780	81,148	207,796	295,155
ASU3	773,244	320,131	114,782	94,177	60,731	55,549	70,843	43,863
Response Time (ms)	>7.0-8.0	>8.0-9.0	>9.0-10.0	>10.0-15.0	>15.0-20.0	>20.0-25.0	>25.0-30.0	>30.0
Read	2,888,437	2,643,256	2,288,941	6,220,670	1,800,612	661,820	384,912	608,129
Write	60,497	39,995	32,095	122,176	113,480	129,783	50,969	123,031
All ASUs	2,948,934	2,683,251	2,321,036	6,342,846	1,914,092	791,603	435,881	731,160
ASU1	2,568,556	2,270,834	1,888,633	4,944,862	1,415,349	546,380	306,426	462,562
ASU2	355,517	397,204	420,470	1,351,771	442,198	173,940	101,251	192,425
ASU3	24,861	15,213	11,933	46,213	56,545	71,283	28,204	76,173

**IOPS Test Run –Response Time Frequency Distribution Graph**

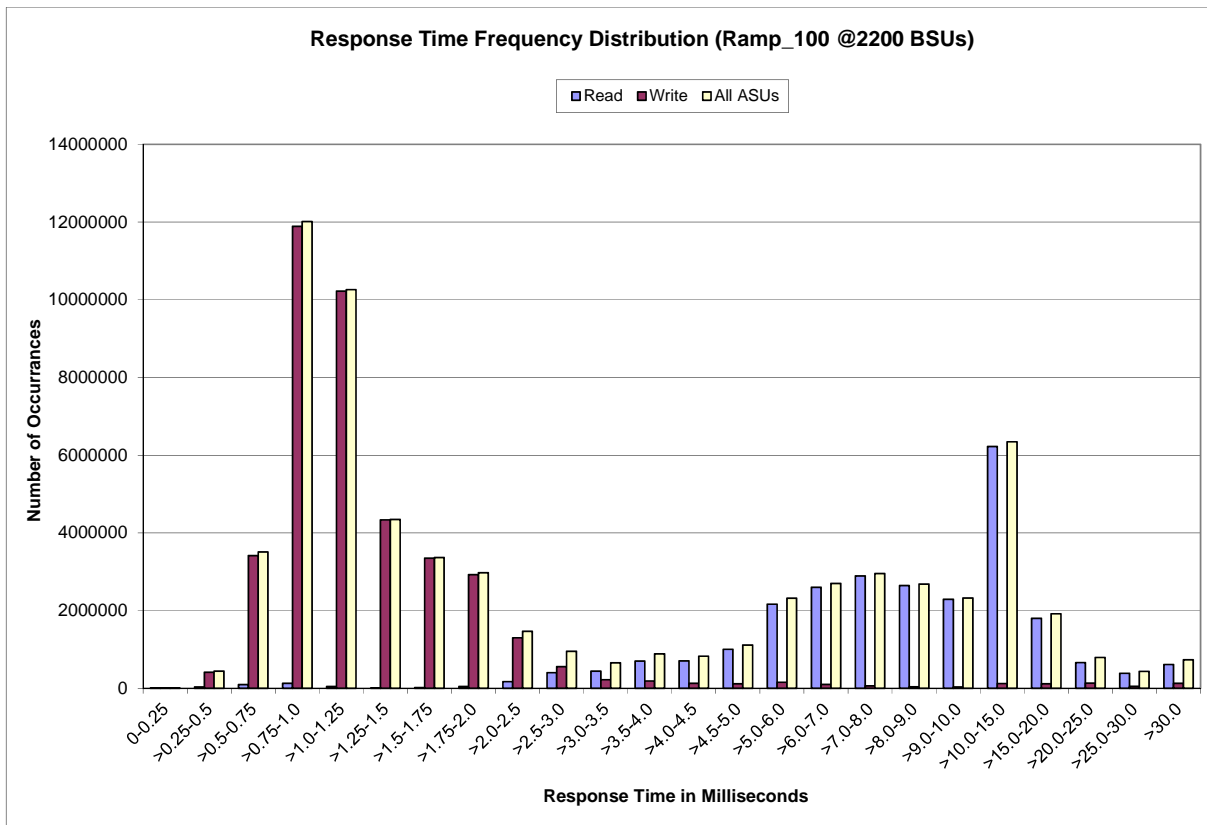

### IOPS Test Run – I/O Request Information

I/O Requests Completed in the Measurement Interval	I/O Requests Completed with Response Time = or < 30 ms	I/O Requests Completed with Response Time > 30 ms
65,991,343	65,260,183	731,160

### IOPS Test Run – Measured Intensity Multiplier and Coefficient of Variation

Clause 3.4.3

**IM – Intensity Multiplier:** The ratio of I/Os for each I/O stream relative to the total I/Os for all I/O streams (ASU1-1 – ASU3-1) as required by the benchmark specification.

Clauses 5.1.10 and 5.3.15.2

**MIM – Measured Intensity Multiplier:** The Measured Intensity Multiplier represents the ratio of measured I/Os for each I/O stream relative to the total I/Os measured for all I/O streams (ASU1-1 – ASU3-1). This value may differ from the corresponding Expected Intensity Multiplier by no more than 5%.

Clause 5.3.15.3

**COV – Coefficient of Variation:** This measure of variation for the Measured Intensity Multiplier cannot exceed 0.2.

	ASU1-1	ASU1-2	ASU1-3	ASU1-4	ASU2-1	ASU2-2	ASU2-3	ASU3-1
<b>IM</b>	<b>0.0350</b>	<b>0.2810</b>	<b>0.0700</b>	<b>0.2100</b>	<b>0.0180</b>	<b>0.0700</b>	<b>0.0350</b>	<b>0.2810</b>
MIM	0.0350	0.2810	0.0700	0.2100	0.0180	0.0700	0.0350	0.2810
COV	0.002	0.000	0.001	0.001	0.003	0.002	0.002	0.001

## Primary Metrics Test – Response Time Ramp Test Phase

### Clause 5.4.4.3

*The Response Time Ramp Test Phase consists of five Test Runs, one each at 95%, 90%, 80%, 50%, and 10% of the load point (100%) used to generate the SPC-1 IOPS™ primary metric. Each of the five Test Runs has a Measurement Interval of ten (10) minutes. The Response Time Ramp Test Phase immediately follows the IOPS Test Phase without any interruption or manual intervention.*

*The five Response Time Ramp Test Runs, in conjunction with the IOPS Test Run (100%), demonstrate the relationship between Average Response Time and I/O Request Throughput for the Tested Storage Configuration (TSC) as illustrated in the response time/throughput curve on page 13.*

*In addition, the Average Response Time measured during the 10% Test Run is the value for the SPC-1 LRT™ metric. That value represents the Average Response Time of a lightly loaded TSC.*

### Clause 9.4.3.7.3

*The following content shall appear in the FDR for the Response Time Ramp Phase:*

- 1. A Response Time Ramp Distribution.*
- 2. The human readable Test Run Results File produced by the Workload Generator for each Test Run within the Response Time Ramp Test Phase.*
- 3. For the 10% Load Level Test Run (SPC-1 LRT™ metric) an Average Response Time Distribution.*
- 4. A listing or screen image of all input parameters supplied to the Workload Generator.*

## SPC-1 Workload Generator Input Parameters

The SPC-1 Workload Generator input parameters for the Sustainability, IOPS, Response Time Ramp, Repeatability, and Persistence Test Runs are documented in “Appendix E: SPC-1 Workload Generator Input Parameters” on Page 88.

## Response Time Ramp Test Results File

A link to each test result file generated from each Response Time Ramp Test Run list listed below.

[95% Load Level](#)

[90% Load Level](#)

[80% Load Level](#)

[50% Load Level](#)

[10% Load Level](#)

### Response Time Ramp Distribution (IOPS) Data

The five Test Runs that comprise the Response Time Ramp Phase are executed at 95%, 90%, 80%, 50%, and 10% of the Business Scaling Unit (BSU) load level used to produce the SPC-1 IOPS™ primary metric. The 100% BSU load level is included in the following Response Time Ramp data tables and graphs for completeness.

100% Load Level - 2200 BSUs					95% Load Level - 2090 BSUs				
	Start	Stop	Interval	Duration		Start	Stop	Interval	Duration
Start-Up/Ramp-Up	2:59:55	3:02:56	0-2	0:03:01	Start-Up/Ramp-Up	3:13:40	3:16:41	0-2	0:03:01
Measurement Interval	3:02:56	3:12:56	3-12	0:10:00	Measurement Interval	3:16:41	3:26:41	3-12	0:10:00
(60 second intervals)	All ASUs	ASU-1	ASU-2	ASU-3	(60 second intervals)	All ASUs	ASU-1	ASU-2	ASU-3
0	110,058.60	65,627.73	13,528.93	30,901.93	0	104,470.03	62,262.17	12,865.92	29,341.95
1	110,001.55	65,563.92	13,507.93	30,929.70	1	104,503.18	62,304.32	12,862.38	29,336.48
2	109,995.17	65,582.52	13,521.53	30,891.12	2	104,519.98	62,297.12	12,839.33	29,383.53
3	109,994.37	65,524.95	13,542.12	30,927.30	3	104,495.77	62,290.85	12,851.82	29,353.10
4	110,038.33	65,575.13	13,512.75	30,950.45	4	104,566.93	62,354.05	12,855.67	29,357.22
5	110,028.15	65,576.03	13,512.70	30,939.42	5	104,478.47	62,242.07	12,866.15	29,370.25
6	109,964.83	65,549.68	13,550.90	30,864.25	6	104,551.68	62,312.05	12,873.37	29,366.27
7	109,951.57	65,523.28	13,533.00	30,895.28	7	104,469.82	62,252.90	12,841.02	29,375.90
8	110,040.35	65,566.78	13,558.15	30,915.42	8	104,486.83	62,254.10	12,879.45	29,353.28
9	109,900.92	65,534.13	13,522.02	30,844.77	9	104,495.40	62,296.10	12,842.40	29,356.90
10	109,972.55	65,527.58	13,533.13	30,911.83	10	104,558.40	62,334.68	12,863.57	29,360.15
11	109,982.87	65,519.13	13,550.53	30,913.20	11	104,484.95	62,266.68	12,843.82	29,374.45
12	109,990.15	65,573.62	13,521.42	30,895.12	12	104,527.00	62,291.43	12,835.80	29,399.77
<b>Average</b>	<b>109,986.41</b>	<b>65,547.03</b>	<b>13,533.67</b>	<b>30,905.70</b>	<b>Average</b>	<b>104,511.53</b>	<b>62,289.49</b>	<b>12,855.31</b>	<b>29,366.73</b>
90% Load Level - 1980 BSUs					80% Load Level - 1760 BSUs				
	Start	Stop	Interval	Duration		Start	Stop	Interval	Duration
Start-Up/Ramp-Up	3:27:25	3:30:26	0-2	0:03:01	Start-Up/Ramp-Up	3:41:10	3:44:11	0-2	0:03:01
Measurement Interval	3:30:26	3:40:26	3-12	0:10:00	Measurement Interval	3:44:11	3:54:11	3-12	0:10:00
(60 second intervals)	All ASUs	ASU-1	ASU-2	ASU-3	(60 second intervals)	All ASUs	ASU-1	ASU-2	ASU-3
0	98,983.40	58,979.68	12,173.27	27,830.45	0	88,055.15	52,513.72	10,836.02	24,705.42
1	99,000.27	59,001.10	12,180.23	27,818.93	1	88,040.73	52,450.02	10,830.90	24,759.82
2	99,046.78	59,040.33	12,192.88	27,813.57	2	88,015.60	52,473.75	10,805.22	24,736.63
3	99,074.75	59,043.28	12,195.90	27,835.57	3	88,031.25	52,452.55	10,827.62	24,751.08
4	98,980.52	58,981.02	12,166.45	27,833.05	4	87,916.25	52,400.63	10,816.13	24,699.48
5	98,991.88	59,000.32	12,156.63	27,834.93	5	87,992.73	52,448.93	10,811.92	24,731.88
6	98,990.65	58,986.65	12,192.15	27,811.85	6	88,001.98	52,432.42	10,857.73	24,711.83
7	99,039.83	59,006.87	12,194.10	27,838.87	7	87,981.40	52,446.92	10,831.43	24,703.05
8	98,971.65	59,011.23	12,161.10	27,799.32	8	88,014.68	52,448.43	10,831.27	24,734.98
9	98,966.00	59,006.67	12,169.62	27,789.72	9	87,979.87	52,463.55	10,820.72	24,695.60
10	98,992.98	59,028.33	12,168.33	27,796.32	10	87,955.65	52,424.32	10,815.85	24,715.48
11	98,951.93	58,956.38	12,156.17	27,839.38	11	87,958.23	52,427.17	10,824.63	24,706.43
12	98,993.63	58,999.05	12,185.98	27,808.60	12	88,022.88	52,502.75	10,794.58	24,725.55
<b>Average</b>	<b>98,995.38</b>	<b>59,001.98</b>	<b>12,174.64</b>	<b>27,818.76</b>	<b>Average</b>	<b>87,985.49</b>	<b>52,444.77</b>	<b>10,823.19</b>	<b>24,717.54</b>
50% Load Level - 1100 BSUs					10% Load Level - 220 BSUs				
	Start	Stop	Interval	Duration		Start	Stop	Interval	Duration
Start-Up/Ramp-Up	3:54:53	3:57:54	0-2	0:03:01	Start-Up/Ramp-Up	4:08:32	4:11:33	0-2	0:03:01
Measurement Interval	3:57:54	4:07:54	3-12	0:10:00	Measurement Interval	4:11:33	4:21:33	3-12	0:10:00
(60 second intervals)	All ASUs	ASU-1	ASU-2	ASU-3	(60 second intervals)	All ASUs	ASU-1	ASU-2	ASU-3
0	55,050.80	32,816.35	6,770.20	15,464.25	0	10,985.28	6,540.12	1,359.53	3,085.63
1	55,009.92	32,772.22	6,782.73	15,454.97	1	10,995.70	6,556.43	1,352.60	3,086.67
2	55,022.58	32,800.63	6,769.95	15,452.00	2	11,003.12	6,547.00	1,355.62	3,100.50
3	55,056.10	32,834.87	6,764.57	15,456.67	3	10,989.92	6,536.63	1,357.95	3,095.33
4	54,982.88	32,761.93	6,775.02	15,445.93	4	11,014.90	6,556.90	1,360.88	3,097.12
5	54,992.95	32,774.38	6,761.65	15,456.92	5	10,989.32	6,555.53	1,353.00	3,080.78
6	54,970.67	32,764.60	6,771.62	15,434.45	6	11,022.27	6,564.63	1,355.88	3,101.75
7	54,964.30	32,719.83	6,780.17	15,464.30	7	10,991.33	6,541.03	1,360.22	3,090.08
8	55,025.27	32,793.22	6,764.75	15,467.30	8	10,994.25	6,564.93	1,346.35	3,082.97
9	54,982.45	32,770.33	6,769.47	15,442.65	9	10,999.43	6,546.40	1,359.52	3,093.52
10	54,971.98	32,772.30	6,761.02	15,438.67	10	11,017.27	6,564.38	1,359.75	3,093.13
11	54,976.67	32,745.73	6,755.87	15,475.07	11	11,001.00	6,551.20	1,351.63	3,098.17
12	55,051.73	32,828.73	6,769.17	15,453.83	12	10,999.43	6,554.40	1,354.53	3,090.50
<b>Average</b>	<b>54,997.50</b>	<b>32,776.59</b>	<b>6,767.33</b>	<b>15,453.58</b>	<b>Average</b>	<b>11,001.91</b>	<b>6,553.61</b>	<b>1,355.97</b>	<b>3,092.34</b>

### Response Time Ramp Distribution (IOPS) Graph

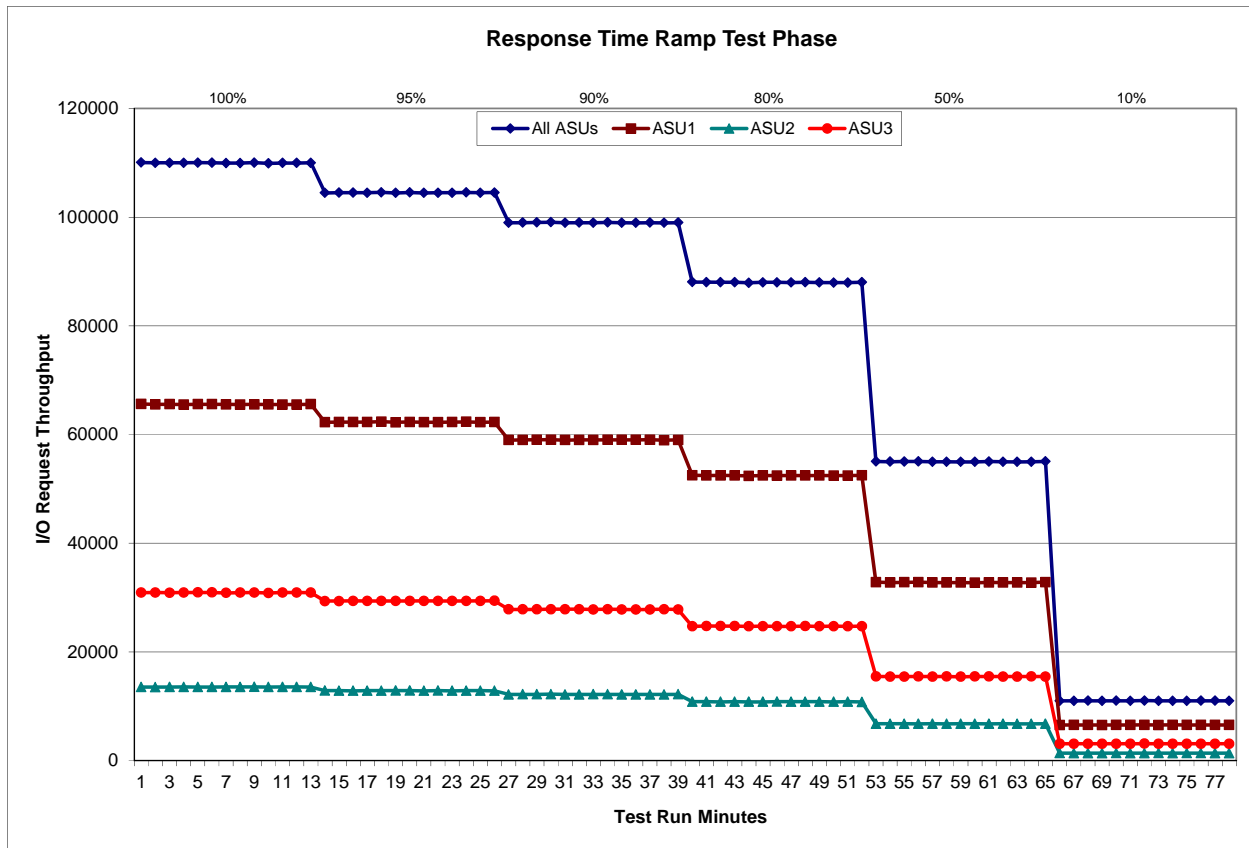



**SPC-1 LRT™ Average Response Time (ms) Distribution Data**

220 BSUs	Start	Stop	Interval	Duration
<i>Start-Up/Ramp-Up</i>	4:08:32	4:11:33	0-2	0:03:01
<i>Measurement Interval</i>	4:11:33	4:21:33	3-12	0:10:00
60 second intervals	All ASUs	ASU1	ASU2	ASU3
0	2.34	3.07	3.22	0.41
1	2.36	3.09	3.29	0.41
2	2.34	3.09	3.23	0.38
3	2.35	3.09	3.24	0.39
4	2.34	3.07	3.26	0.40
5	2.35	3.08	3.25	0.40
6	2.35	3.08	3.26	0.40
7	2.35	3.09	3.24	0.39
8	2.37	3.11	3.27	0.41
9	2.35	3.09	3.25	0.39
10	2.35	3.09	3.24	0.39
11	2.35	3.10	3.27	0.39
12	2.38	3.12	3.29	0.42
<b>Average</b>	<b>2.36</b>	<b>3.09</b>	<b>3.26</b>	<b>0.40</b>

**SPC-1 LRT™ Average Response Time (ms) Distribution Graph**

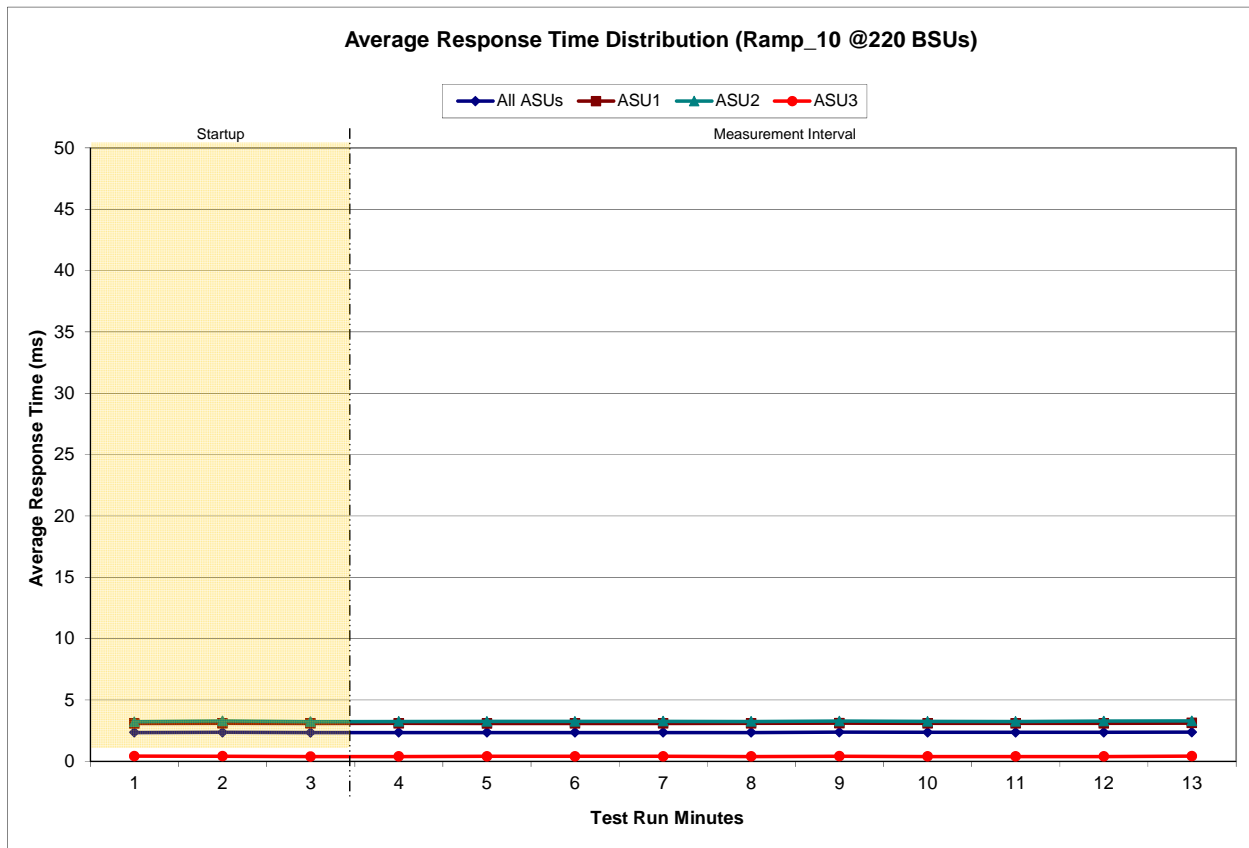

**SPC-1 LRT™ (10%) – Measured Intensity Multiplier and Coefficient of Variation**

Clause 3.4.3

**IM – Intensity Multiplier:** The ratio of I/Os for each I/O stream relative to the total I/Os for all I/O streams (ASU1-1 – ASU3-1) as required by the benchmark specification.

Clauses 5.1.10 and 5.3.15.2

**MIM – Measured Intensity Multiplier:** The Measured Intensity Multiplier represents the ratio of measured I/Os for each I/O stream relative to the total I/Os measured for all I/O streams (ASU1-1 – ASU3-1). This value may differ from the corresponding Expected Intensity Multiplier by no more than 5%.

Clause 5.3.15.3

**COV – Coefficient of Variation:** This measure of variation for the Measured Intensity Multiplier cannot exceed 0.2.

	ASU1-1	ASU1-2	ASU1-3	ASU1-4	ASU2-1	ASU2-2	ASU2-3	ASU3-1
<b>IM</b>	<b>0.0350</b>	<b>0.2810</b>	<b>0.0700</b>	<b>0.2100</b>	<b>0.0180</b>	<b>0.0700</b>	<b>0.0350</b>	<b>0.2810</b>
MIM	0.0350	0.2809	0.0697	0.2101	0.0181	0.0702	0.0350	0.2811
COV	0.007	0.001	0.004	0.002	0.010	0.004	0.005	0.002

## Repeatability Test

### Clause 5.4.5

*The Repeatability Test demonstrates the repeatability and reproducibility of the SPC-1 IOPS™ primary metric and the SPC-1 LRT™ metric generated in earlier Test Runs.*

*There are two identical Repeatability Test Phases. Each Test Phase contains two Test Runs. Each of the Test Runs will have a Measurement Interval of no less than ten (10) minutes. The two Test Runs in each Test Phase will be executed without interruption or any type of manual intervention.*

*The first Test Run in each Test Phase is executed at the 10% load point. The Average Response Time from each of the Test Runs is compared to the SPC-1 LRT™ metric. Each Average Response Time value must be less than the SPC-1 LRT™ metric plus 5% or less than the SPC-1 LRT™ metric plus one (1) millisecond (ms).*

*The second Test Run in each Test Phase is executed at the 100% load point. The I/O Request Throughput from the Test Runs is compared to the SPC-1 IOPS™ primary metric. Each I/O Request Throughput value must be greater than the SPC-1 IOPS™ primary metric minus 5%. In addition, the Average Response Time for each Test Run cannot exceed 30 milliseconds.*

*If any of the above constraints are not met, the benchmark measurement is invalid.*

### Clause 9.4.3.7.4

*The following content shall appear in the FDR for each Test Run in the two Repeatability Test Phases:*

- 1. A table containing the results of the Repeatability Test.*
- 2. An I/O Request Throughput Distribution graph and table.*
- 3. An Average Response Time Distribution graph and table.*
- 4. The human readable Test Run Results File produced by the Workload Generator.*
- 5. A listing or screen image of all input parameters supplied to the Workload Generator.*

## SPC-1 Workload Generator Input Parameters

The SPC-1 Workload Generator input parameters for the Sustainability, IOPS, Response Time Ramp, Repeatability, and Persistence Test Runs are documented in “Appendix E: SPC-1 Workload Generator Input Parameters” on Page 88.

**Repeatability Test Results File**

The values for the SPC-1 IOPS™, SPC-1 LRT™, and the Repeatability Test measurements are listed in the tables below.

	SPC-1 IOPS™
<b>Primary Metrics</b>	<b>109,986.41</b>
<b>Repeatability Test Phase 1</b>	110,007.92
<b>Repeatability Test Phase 2</b>	110,011.83

The SPC-1 IOPS™ values in the above table were generated using 100% of the specified Business Scaling Unit (BSU) load level. Each of the Repeatability Test Phase values for SPC-1 IOPS™ must be greater than 95% of the reported SPC-1 IOPS™ Primary Metric.

	SPC-1 LRT™
<b>Primary Metrics</b>	<b>2.36 ms</b>
<b>Repeatability Test Phase 1</b>	2.36 ms
<b>Repeatability Test Phase 2</b>	2.35 ms

The average response time values in the SPC-1 LRT™ column were generated using 10% of the specified Business Scaling Unit (BSU) load level. Each of the Repeatability Test Phase values for SPC-1 LRT™ must be less than 105% of the reported SPC-1 LRT™ Primary Metric or less than the reported SPC-1 LRT™ Primary Metric minus one (1) millisecond (ms).

A link to the test result file generated from each Repeatability Test Run is listed below.

- [Repeatability Test Phase 1, Test Run 1 \(LRT\)](#)
- [Repeatability Test Phase 1, Test Run 2 \(IOPS\)](#)
- [Repeatability Test Phase 2, Test Run 1 \(LRT\)](#)
- [Repeatability Test Phase 2, Test Run 2 \(IOPS\)](#)

**Repeatability 1 LRT – I/O Request Throughput Distribution Data**

220 BSUs	Start	Stop	Interval	Duration
<i>Start-Up/Ramp-Up</i>	4:22:18	4:25:18	0-2	0:03:00
<i>Measurement Interval</i>	4:25:18	4:35:18	3-12	0:10:00
60 second intervals	All ASUs	ASU1	ASU2	ASU3
0	11,012.53	6,547.22	1,354.05	3,111.27
1	11,007.10	6,558.67	1,348.17	3,100.27
2	10,972.13	6,538.53	1,353.35	3,080.25
3	11,011.90	6,563.62	1,354.55	3,093.73
4	11,001.13	6,552.57	1,362.05	3,086.52
5	10,997.48	6,553.87	1,352.68	3,090.93
6	11,012.85	6,552.37	1,354.70	3,105.78
7	10,997.78	6,548.03	1,355.88	3,093.87
8	10,987.13	6,558.95	1,352.28	3,075.90
9	11,019.25	6,560.07	1,358.93	3,100.25
10	10,992.20	6,561.50	1,352.00	3,078.70
11	10,986.40	6,551.12	1,353.38	3,081.90
12	11,003.95	6,564.40	1,348.77	3,090.78
<b>Average</b>	<b>11,001.01</b>	<b>6,556.65</b>	<b>1,354.52</b>	<b>3,089.84</b>

**Repeatability 1 LRT – I/O Request Throughput Distribution Graph**

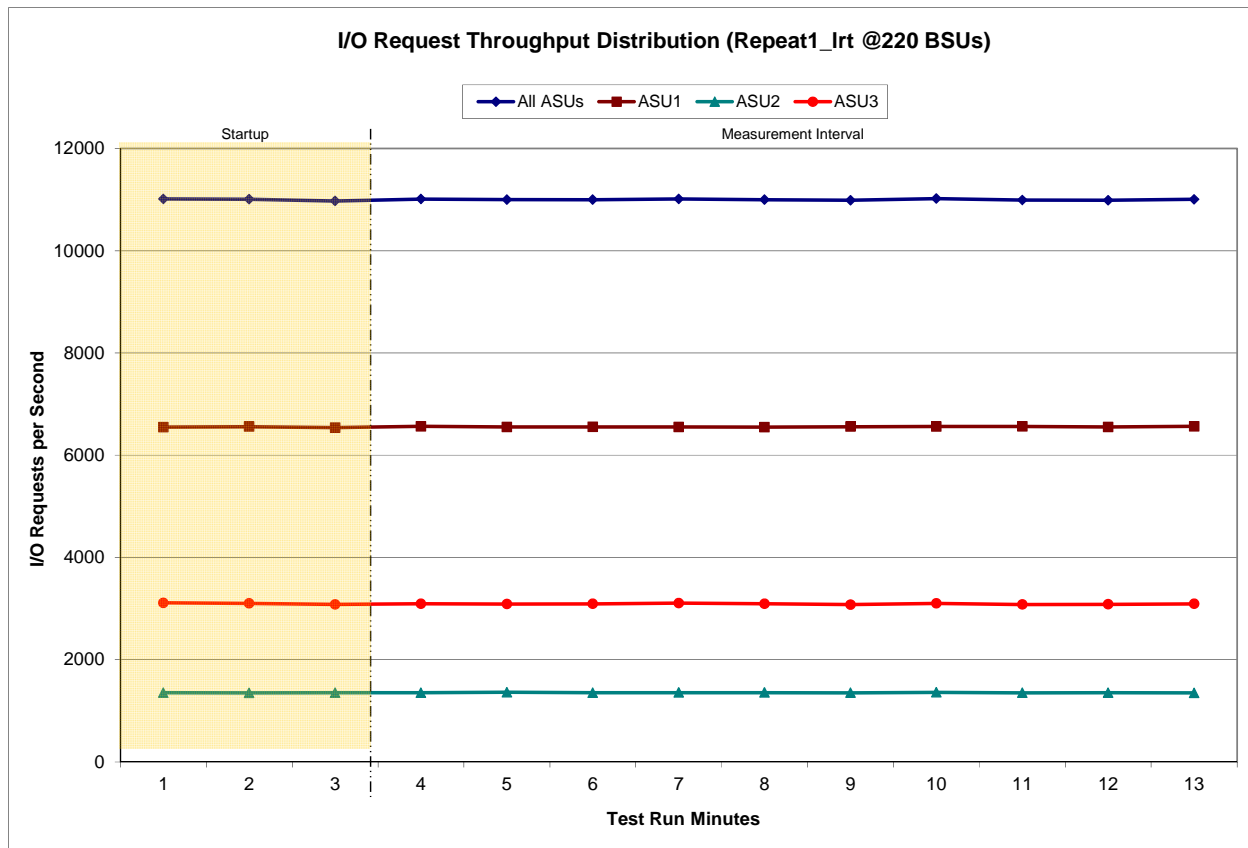

**Repeatability 1 LRT –Average Response Time (ms) Distribution Data**

220 BSUs	Start	Stop	Interval	Duration
<i>Start-Up/Ramp-Up</i>	4:22:18	4:25:18	0-2	0:03:00
<i>Measurement Interval</i>	4:25:18	4:35:18	3-12	0:10:00
60 second intervals	All ASUs	ASU1	ASU2	ASU3
0	2.34	3.07	3.23	0.40
1	2.35	3.08	3.28	0.39
2	2.35	3.09	3.23	0.40
3	2.35	3.09	3.25	0.40
4	2.38	3.12	3.29	0.40
5	2.39	3.14	3.29	0.41
6	2.36	3.10	3.27	0.40
7	2.36	3.09	3.27	0.39
8	2.36	3.09	3.25	0.39
9	2.35	3.09	3.24	0.39
10	2.34	3.08	3.25	0.38
11	2.35	3.08	3.27	0.40
12	2.35	3.09	3.25	0.39
<b>Average</b>	<b>2.36</b>	<b>3.10</b>	<b>3.26</b>	<b>0.39</b>

**Repeatability 1 LRT –Average Response Time (ms) Distribution Graph**

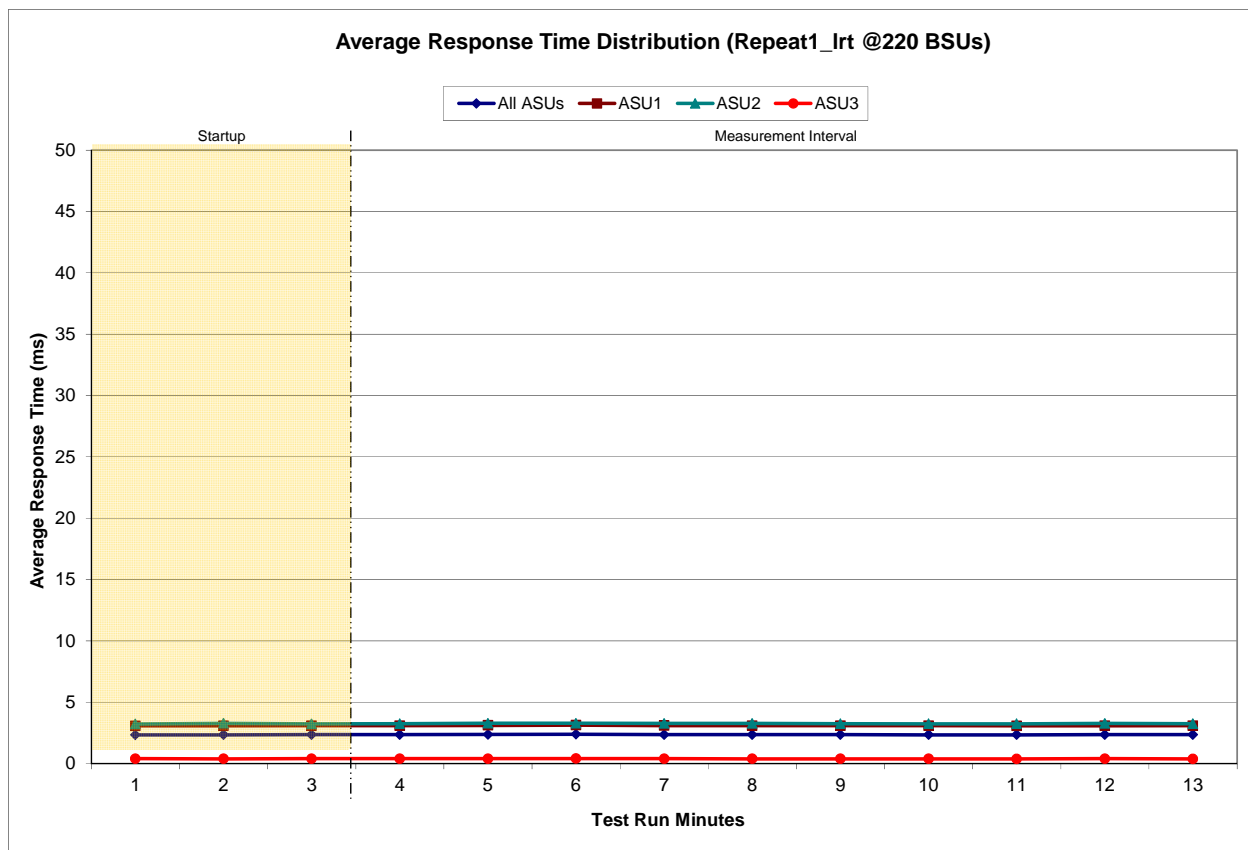

**Repeatability 1 IOPS – I/O Request Throughput Distribution Data**

2,200 BSUs	Start	Stop	Interval	Duration
<i>Start-Up/Ramp-Up</i>	4:36:05	4:39:06	0-2	0:03:01
<i>Measurement Interval</i>	4:39:06	4:49:06	3-12	0:10:00
60 second intervals	All ASUs	ASU1	ASU2	ASU3
0	110,055.12	65,611.60	13,536.27	30,907.25
1	110,043.62	65,588.73	13,517.93	30,936.95
2	109,992.27	65,554.23	13,540.08	30,897.95
3	109,989.45	65,529.93	13,527.77	30,931.75
4	109,923.67	65,551.37	13,522.42	30,849.88
5	109,999.98	65,566.97	13,526.53	30,906.48
6	110,028.13	65,520.55	13,574.92	30,932.67
7	110,017.35	65,574.63	13,518.28	30,924.43
8	109,978.47	65,531.05	13,537.08	30,910.33
9	110,038.67	65,594.43	13,552.52	30,891.72
10	110,016.77	65,563.43	13,528.55	30,924.78
11	110,049.98	65,572.48	13,538.85	30,938.65
12	110,036.73	65,605.13	13,525.08	30,906.52
<b>Average</b>	<b>110,007.92</b>	<b>65,561.00</b>	<b>13,535.20</b>	<b>30,911.72</b>

**Repeatability 1 IOPS – I/O Request Throughput Distribution Graph**

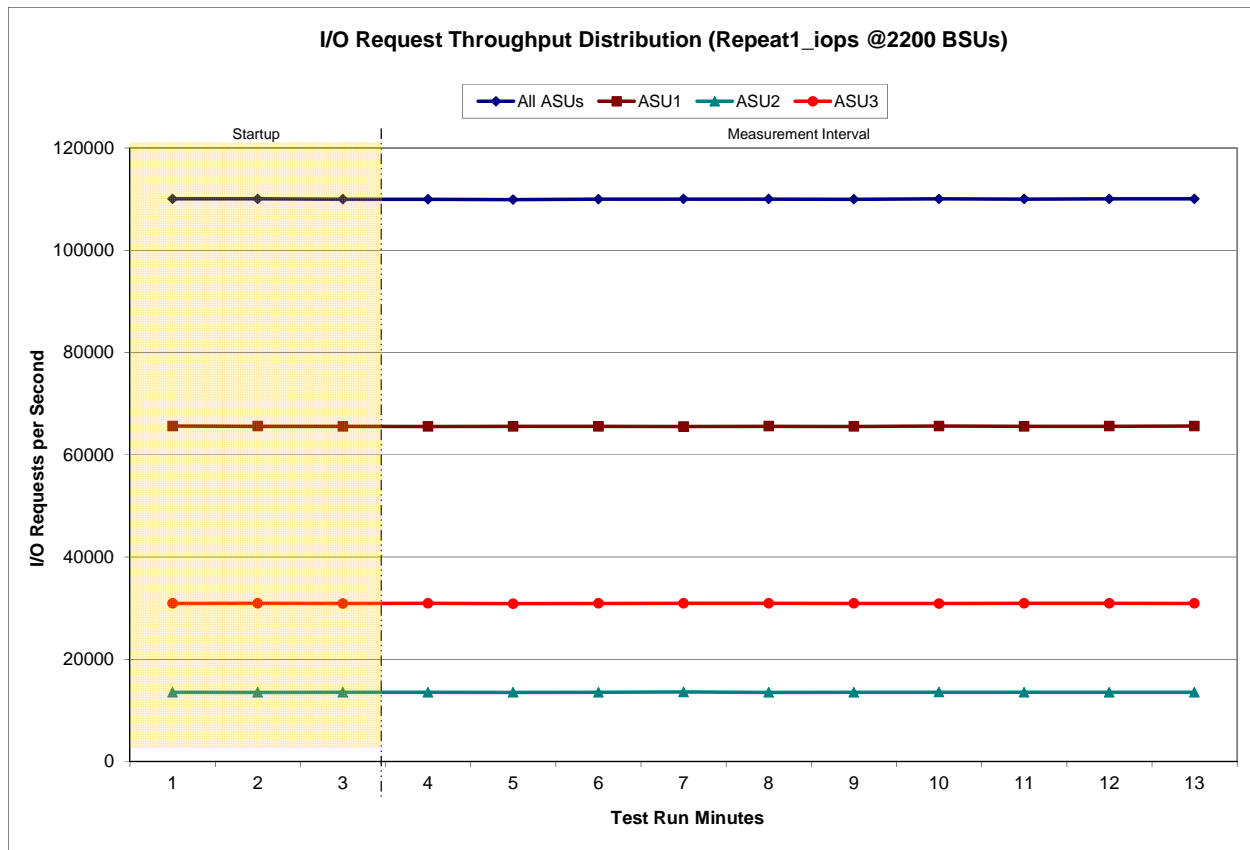

**Repeatability 1 IOPS –Average Response Time (ms) Distribution Data**

2,200 BSUs Start-Up/Ramp-Up Measurement Interval	Start	Stop	Interval	Duration
	4:36:05	4:39:06	0-2	0:03:01
	4:39:06	4:49:06	3-12	0:10:00
60 second intervals	All ASUs	ASU1	ASU2	ASU3
0	4.74	5.78	6.72	1.66
1	4.81	5.89	6.82	1.65
2	4.96	6.03	6.91	1.84
3	5.19	6.33	7.67	1.70
4	5.19	6.27	7.52	1.89
5	4.95	6.04	6.97	1.76
6	5.29	6.41	7.81	1.80
7	4.97	6.02	6.92	1.88
8	4.88	5.97	6.94	1.67
9	5.46	6.55	8.02	2.03
10	5.13	6.20	7.23	1.94
11	4.99	6.04	6.98	1.90
12	5.09	6.17	7.27	1.84
<b>Average</b>	<b>5.11</b>	<b>6.20</b>	<b>7.33</b>	<b>1.84</b>

**Repeatability 1 IOPS –Average Response Time (ms) Distribution Graph**

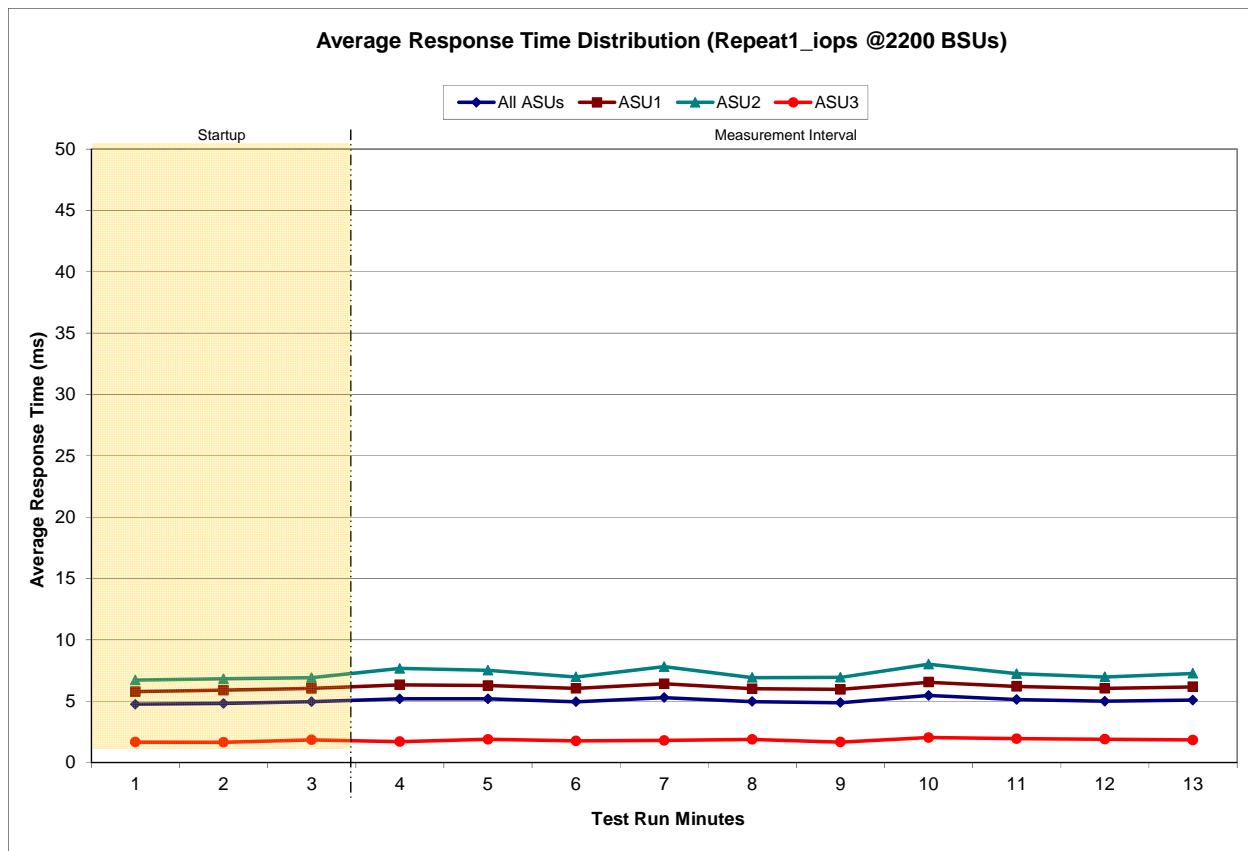



**Repeatability 2 LRT – I/O Request Throughput Distribution Data**

220 BSUs	Start	Stop	Interval	Duration
<i>Start-Up/Ramp-Up</i>	4:49:53	4:52:53	0-2	0:03:00
<i>Measurement Interval</i>	4:52:53	5:02:53	3-12	0:10:00
<b>60 second intervals</b>	<b>All ASUs</b>	<b>ASU1</b>	<b>ASU2</b>	<b>ASU3</b>
0	11,008.55	6,561.17	1,353.95	3,093.43
1	11,005.10	6,561.25	1,353.62	3,090.23
2	10,996.88	6,563.30	1,359.02	3,074.57
3	10,999.20	6,559.68	1,356.62	3,082.90
4	11,007.63	6,557.75	1,344.23	3,105.65
5	11,005.72	6,553.67	1,349.88	3,102.17
6	11,032.90	6,568.37	1,354.60	3,109.93
7	11,004.75	6,560.43	1,349.90	3,094.42
8	11,015.18	6,562.75	1,358.35	3,094.08
9	10,995.98	6,554.45	1,355.22	3,086.32
10	10,992.27	6,564.08	1,337.85	3,090.33
11	10,980.60	6,538.73	1,351.68	3,090.18
12	10,986.27	6,549.32	1,346.78	3,090.17
<b>Average</b>	<b>11,002.05</b>	<b>6,556.92</b>	<b>1,350.51</b>	<b>3,094.62</b>

**Repeatability 2 LRT – I/O Request Throughput Distribution Graph**

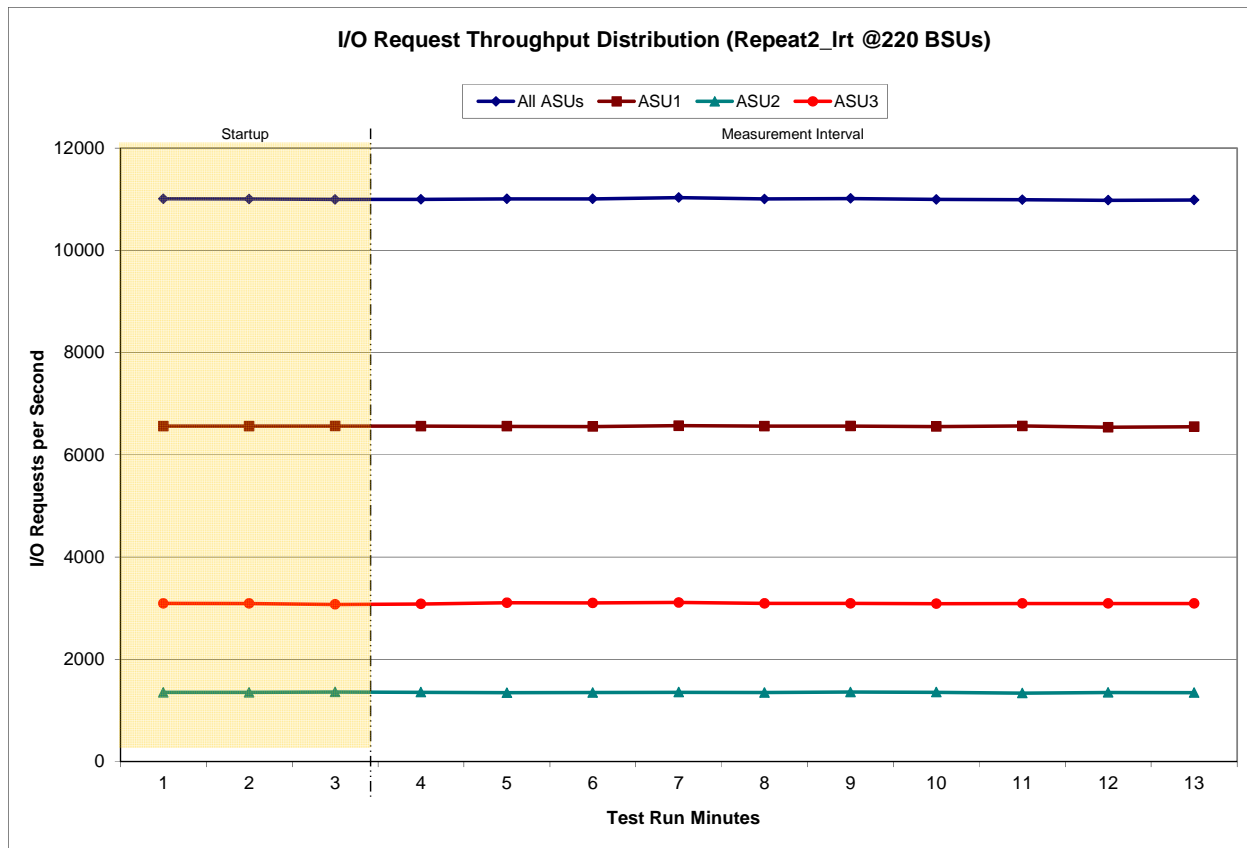

**Repeatability 2 LRT –Average Response Time (ms) Distribution Data**

220 BSUs	Start	Stop	Interval	Duration
<i>Start-Up/Ramp-Up</i>	4:49:53	4:52:53	0-2	0:03:00
<i>Measurement Interval</i>	4:52:53	5:02:53	3-12	0:10:00
<b>60 second intervals</b>	<b>All ASUs</b>	<b>ASU1</b>	<b>ASU2</b>	<b>ASU3</b>
0	2.32	3.06	3.19	0.38
1	2.35	3.08	3.24	0.39
2	2.37	3.10	3.26	0.41
3	2.34	3.08	3.23	0.38
4	2.34	3.08	3.23	0.39
5	2.35	3.09	3.25	0.40
6	2.34	3.07	3.24	0.38
7	2.35	3.09	3.27	0.40
8	2.34	3.08	3.25	0.38
9	2.37	3.10	3.31	0.40
10	2.37	3.10	3.28	0.41
11	2.35	3.09	3.24	0.40
12	2.36	3.10	3.26	0.40
<b>Average</b>	<b>2.35</b>	<b>3.09</b>	<b>3.26</b>	<b>0.40</b>

**Repeatability 2 LRT –Average Response Time (ms) Distribution Graph**

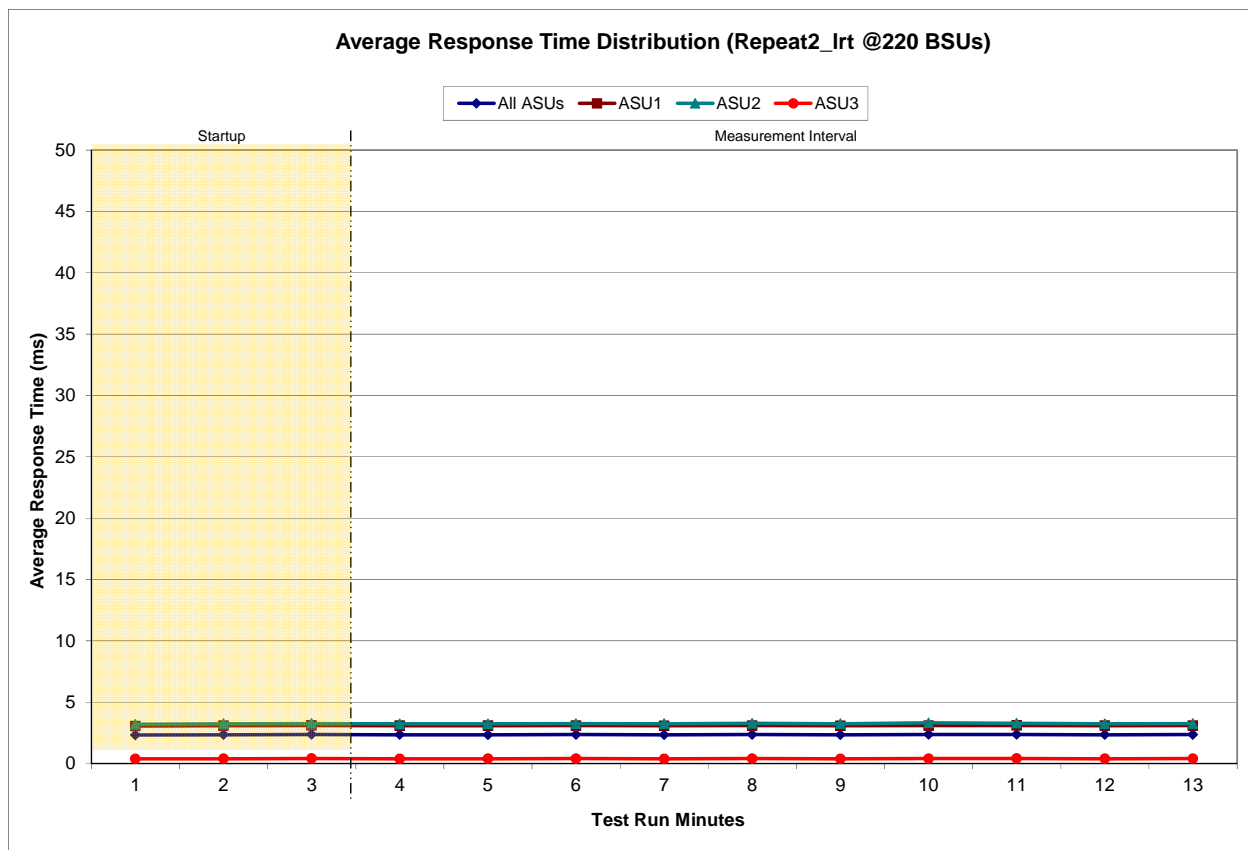

**Repeatability 2 IOPS – I/O Request Throughput Distribution Data**

2,220 BSUs	Start	Stop	Interval	Duration
<i>Start-Up/Ramp-Up</i>	5:03:40	5:06:41	0-2	0:03:01
<i>Measurement Interval</i>	5:06:41	5:16:41	3-12	0:10:00
60 second intervals	All ASUs	ASU1	ASU2	ASU3
0	110,084.43	65,564.85	13,547.70	30,971.88
1	110,057.95	65,570.57	13,546.33	30,941.05
2	110,018.03	65,566.68	13,532.12	30,919.23
3	110,088.42	65,604.73	13,512.95	30,970.73
4	110,064.23	65,610.92	13,529.40	30,923.92
5	110,007.50	65,556.13	13,536.42	30,914.95
6	110,022.57	65,592.63	13,490.72	30,939.22
7	109,961.90	65,546.23	13,513.43	30,902.23
8	110,056.23	65,606.48	13,524.08	30,925.67
9	109,927.32	65,536.98	13,497.37	30,892.97
10	109,965.72	65,520.57	13,540.18	30,904.97
11	110,059.38	65,616.83	13,510.70	30,931.85
12	109,965.03	65,534.95	13,513.90	30,916.18
<b>Average</b>	<b>110,011.83</b>	<b>65,572.65</b>	<b>13,516.92</b>	<b>30,922.27</b>

**Repeatability 2 IOPS – I/O Request Throughput Distribution Graph**

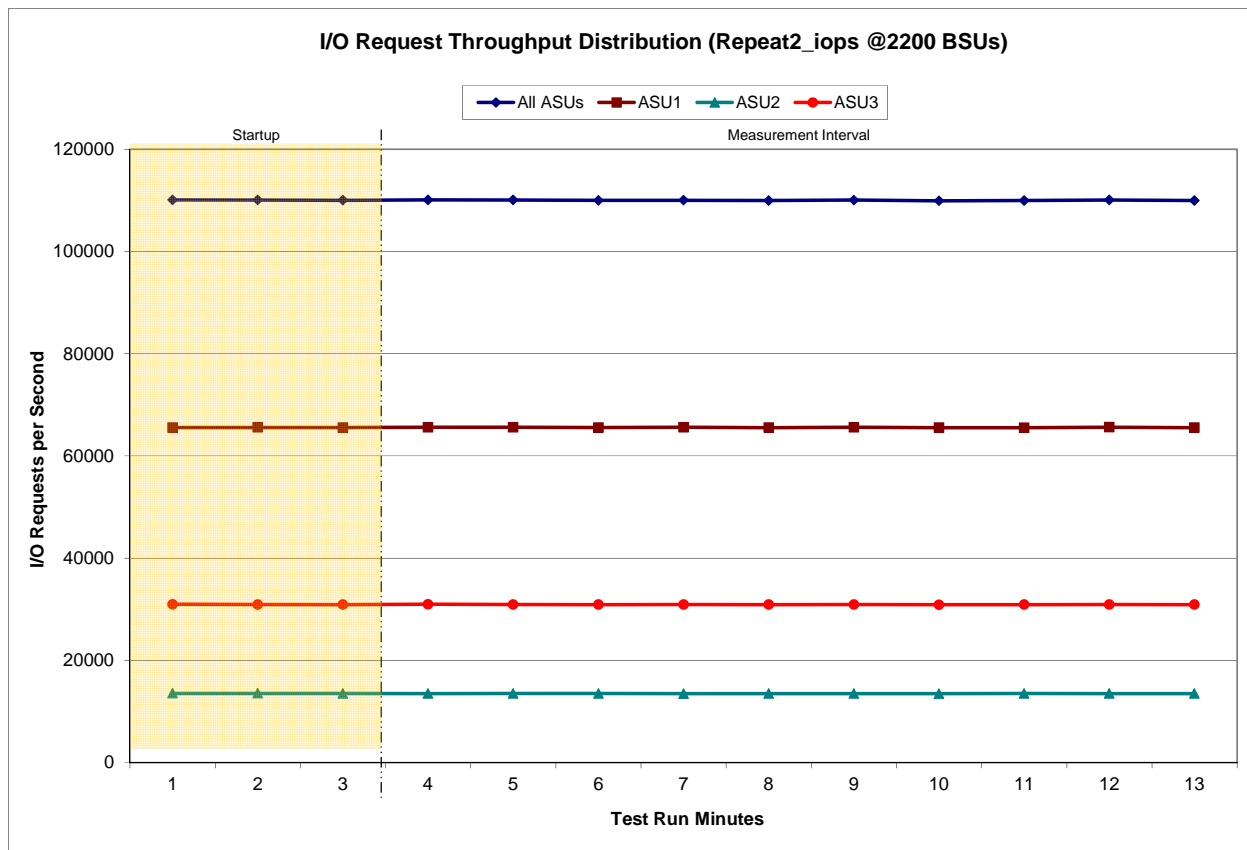

**Repeatability 2 IOPS –Average Response Time (ms) Distribution Data**

2,220 BSUs	Start	Stop	Interval	Duration
<i>Start-Up/Ramp-Up</i>	5:03:40	5:06:41	0-2	0:03:01
<i>Measurement Interval</i>	5:06:41	5:16:41	3-12	0:10:00
60 second intervals	All ASUs	ASU1	ASU2	ASU3
0	4.80	5.83	6.78	1.73
1	4.90	5.97	6.88	1.77
2	5.05	6.14	7.30	1.77
3	5.11	6.21	7.38	1.78
4	5.08	6.15	7.19	1.89
5	5.11	6.21	7.50	1.74
6	5.11	6.23	7.43	1.73
7	5.03	6.08	7.07	1.91
8	5.08	6.18	7.42	1.71
9	4.89	5.97	7.00	1.66
10	5.05	6.16	7.29	1.73
11	5.19	6.30	7.66	1.76
12	5.02	6.10	7.17	1.80
<b>Average</b>	<b>5.07</b>	<b>6.16</b>	<b>7.31</b>	<b>1.77</b>

**Repeatability 2 IOPS –Average Response Time (ms) Distribution Graph**

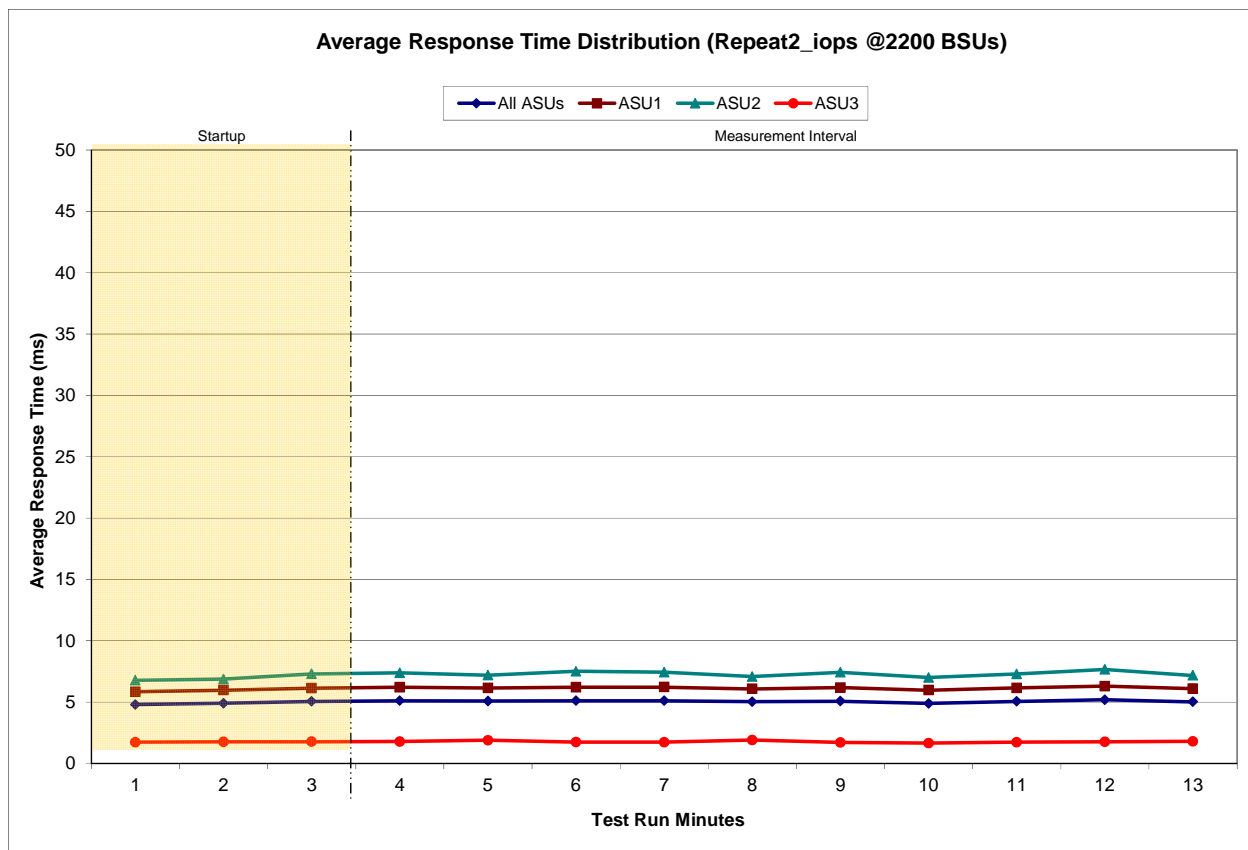

**Repeatability 1 (LRT)**  
**Measured Intensity Multiplier and Coefficient of Variation**

Clause 3.4.3

**IM – Intensity Multiplier:** The ratio of I/Os for each I/O stream relative to the total I/Os for all I/O streams (ASU1-1 – ASU3-1) as required by the benchmark specification.

Clauses 5.1.10 and 5.3.15.2

**MIM – Measured Intensity Multiplier:** The Measured Intensity Multiplier represents the ratio of measured I/Os for each I/O stream relative to the total I/Os measured for all I/O streams (ASU1-1 – ASU3-1). This value may differ from the corresponding Expected Intensity Multiplier by no more than 5%.

Clause 5.3.15.3

**COV – Coefficient of Variation:** This measure of variation for the Measured Intensity Multiplier cannot exceed 0.2.

	ASU1-1	ASU1-2	ASU1-3	ASU1-4	ASU2-1	ASU2-2	ASU2-3	ASU3-1
<b>IM</b>	<b>0.0350</b>	<b>0.2810</b>	<b>0.0700</b>	<b>0.2100</b>	<b>0.0180</b>	<b>0.0700</b>	<b>0.0350</b>	<b>0.2810</b>
MIM	0.0350	0.2811	0.0700	0.2099	0.0180	0.0701	0.0350	0.2809
COV	0.009	0.002	0.004	0.002	0.006	0.004	0.006	0.002

**Repeatability 1 (IOPS)**  
**Measured Intensity Multiplier and Coefficient of Variation**

	ASU1-1	ASU1-2	ASU1-3	ASU1-4	ASU2-1	ASU2-2	ASU2-3	ASU3-1
<b>IM</b>	<b>0.0350</b>	<b>0.2810</b>	<b>0.0700</b>	<b>0.2100</b>	<b>0.0180</b>	<b>0.0700</b>	<b>0.0350</b>	<b>0.2810</b>
MIM	0.0350	0.2810	0.0700	0.2100	0.0180	0.0700	0.0350	0.2810
COV	0.002	0.001	0.002	0.001	0.003	0.001	0.002	0.001

**Repeatability 2 (LRT)**  
**Measured Intensity Multiplier and Coefficient of Variation**

	ASU1-1	ASU1-2	ASU1-3	ASU1-4	ASU2-1	ASU2-2	ASU2-3	ASU3-1
<b>IM</b>	<b>0.0350</b>	<b>0.2810</b>	<b>0.0700</b>	<b>0.2100</b>	<b>0.0180</b>	<b>0.0700</b>	<b>0.0350</b>	<b>0.2810</b>
MIM	0.0350	0.2810	0.0699	0.2101	0.0179	0.0698	0.0350	0.2813
COV	0.007	0.002	0.004	0.003	0.006	0.005	0.008	0.002

**Repeatability 2 (IOPS)**  
**Measured Intensity Multiplier and Coefficient of Variation**

	ASU1-1	ASU1-2	ASU1-3	ASU1-4	ASU2-1	ASU2-2	ASU2-3	ASU3-1
<i>IM</i>	<i>0.0350</i>	<i>0.2810</i>	<i>0.0700</i>	<i>0.2100</i>	<i>0.0180</i>	<i>0.0700</i>	<i>0.0350</i>	<i>0.2810</i>
MIM	0.0350	0.2811	0.0700	0.2100	0.0180	0.0699	0.0350	0.2811
COV	0.002	0.001	0.002	0.001	0.003	0.002	0.002	0.000

## Data Persistence Test

### Clause 6

*The Data Persistence Test demonstrates the Tested Storage Configuration (TSC):*

- *Is capable of maintain data integrity across a power cycle.*
- *Ensures the transfer of data between Logical Volumes and host systems occurs without corruption or loss.*

*The SPC-1 Workload Generator will write 16 block I/O requests at random over the total Addressable Storage Capacity of the TSC for ten (10) minutes at a minimum of 25% of the load used to generate the SPC-1 IOPS™ primary metric. The bit pattern selected to be written to each block as well as the address of the block will be retained in a log file.*

*The Tested Storage Configuration (TSC) will be shutdown and restarted using a power off/power on cycle at the end of the above sequence of write operations. In addition, any caches employing battery backup must be flushed/emptied.*

*The SPC-1 Workload Generator will then use the above log file to verify each block written contains the correct bit pattern.*

### Clause 9.4.3.8

*The following content shall appear in this section of the FDR:*

1. *A listing or screen image of all input parameters supplied to the Workload Generator.*
2. *For the successful Data Persistence Test Run, a table illustrating key results. The content, appearance, and format of this table are specified in Table 9-12. Information displayed in this table shall be obtained from the Test Run Results File referenced below in #3.*
3. *For the successful Data Persistence Test Run, the human readable Test Run Results file produced by the Workload Generator (may be contained in an appendix).*

## SPC-1 Workload Generator Input Parameters

The SPC-1 Workload Generator input parameters for the Sustainability, IOPS, Response Time Ramp, Repeatability, and Persistence Test Runs are documented in “Appendix E: SPC-1 Workload Generator Input Parameters” on Page 88.

## Data Persistence Test Results File

A link to each test result file generated from each Data Persistence Test is listed below.

[Persistence 1 Test Results File](#)

[Persistence 2 Test Results File](#)

### Data Persistence Test Results

<b>Data Persistence Test Results</b>	
Data Persistence Test Run Number: 1	
Total Number of Logical Blocks Written	373,270
Total Number of Logical Blocks Verified	372,323
Total Number of Logical Blocks that Failed Verification	0
Time Duration for Writing Test Logical Blocks	5 minutes
Size in bytes of each Logical Block	1,024
Number of Failed I/O Requests in the process of the Test	0

If approved by the SPC Auditor, the SPC-2 Persistence Test may be used to meet the SPC-1 persistence requirements. Both the SPC-1 and SPC-2 Persistence Tests provide the same level of functionality and verification of data integrity. The SPC-2 Persistence Test may be easily configured to address an SPC-1 storage configuration. The SPC-2 Persistence Test extends the size of storage configurations that may be tested and significantly reduces the test duration of such configurations.

The SPC-2 Persistence Test was approved for use in this set of audited measurements.

In some cases the same address was the target of multiple writes, which resulted in more Logical Blocks Written than Logical Blocks Verified. In the case of multiple writes to the same address, the pattern written and verified must be associated with the last write to that address.



## **PRICED STORAGE CONFIGURATION AVAILABILITY DATE**

### **Clause 9.4.3.9**

*The committed delivery data for general availability (Availability Date) of all products that comprise the Priced Storage Configuration must be reported. When the Priced Storage Configuration includes products or components with different availability dates, the reported Availability Date for the Priced Storage Configuration must be the date at which all components are committed to be available.*

The Hitachi Unified Storage 150as documented in this Full Disclosure Report became available on April 24, 2012 for customer purchase and shipment.

## **PRICING INFORMATION**

### **Clause 9.4.3.3.6**

*The Executive Summary shall contain a pricing spreadsheet as documented in Clause 8.3.1.*

Pricing information may be found in the Priced Storage Configuration Pricing section on page 14.

## **TESTED STORAGE CONFIGURATION (TSC) AND PRICED STORAGE CONFIGURATION DIFFERENCES**

### **Clause 9.4.3.3.8**

*The Executive Summary shall contain a list of all differences between the Tested Storage Configuration (TSC) and the Priced Storage Configuration.*

A list of all differences between the Tested Storage Configuration (TSC) and Priced Storage Configuration may be found in the Executive Summary portion of this document on page 14.

## **ANOMALIES OR IRREGULARITIES**

### **Clause 9.4.3.10**

*The FDR shall include a clear and complete description of any anomalies or irregularities encountered in the course of executing the SPC-1 benchmark that may in any way call into question the accuracy, verifiability, or authenticity of information published in this FDR.*

There were no anomalies or irregularities encountered during the SPC-1 Onsite Audit of the Hitachi Unified Storage 150.

## **APPENDIX A: SPC-1 GLOSSARY**

### “Decimal” (*powers of ten*) Measurement Units

In the storage industry, the terms “kilo”, “mega”, “giga”, “tera”, “peta”, and “exa” are commonly used prefixes for computing performance and capacity. For the purposes of the SPC workload definitions, all of the following terms are defined in “powers of ten” measurement units.

A kilobyte (KB) is equal to 1,000 ( $10^3$ ) bytes.

A megabyte (MB) is equal to 1,000,000 ( $10^6$ ) bytes.

A gigabyte (GB) is equal to 1,000,000,000 ( $10^9$ ) bytes.

A terabyte (TB) is equal to 1,000,000,000,000 ( $10^{12}$ ) bytes.

A petabyte (PB) is equal to 1,000,000,000,000,000 ( $10^{15}$ ) bytes

An exabyte (EB) is equal to 1,000,000,000,000,000,000 ( $10^{18}$ ) bytes

### “Binary” (*powers of two*) Measurement Units

The sizes reported by many operating system components use “powers of two” measurement units rather than “power of ten” units. The following standardized definitions and terms are also valid and may be used in this document.

A kibibyte (KiB) is equal to 1,024 ( $2^{10}$ ) bytes.

A mebibyte (MiB) is equal to 1,048,576 ( $2^{20}$ ) bytes.

A gibibyte (GiB) is equal to 1,073,741,824 ( $2^{30}$ ) bytes.

A tebibyte (TiB) is equal to 1,099,511,627,776 ( $2^{40}$ ) bytes.

A pebibyte (PiB) is equal to 1,125,899,906,842,624 ( $2^{50}$ ) bytes.

An exbibyte (EiB) is equal to 1,152,921,504,606,846,967 ( $2^{60}$ ) bytes.

## **SPC-1 Data Repository Definitions**

**Total ASU Capacity:** The total storage capacity read and written in the course of executing the SPC-1 benchmark.

**Application Storage Unit (ASU):** The logical interface between the storage and SPC-1 Workload Generator. The three ASUs (Data, User, and Log) are typically implemented on one or more Logical Volume.

**Logical Volume:** The division of Addressable Storage Capacity into individually addressable logical units of storage used in the SPC-1 benchmark. Each Logical Volume is implemented as a single, contiguous address space.

**Addressable Storage Capacity:** The total storage (sum of Logical Volumes) that can be read and written by application programs such as the SPC-1 Workload Generator.

**Configured Storage Capacity:** This capacity includes the Addressable Storage Capacity and any other storage (parity disks, hot spares, etc.) necessary to implement the Addressable Storage Capacity.

**Physical Storage Capacity:** The formatted capacity of all storage devices physically present in the Tested Storage Configuration (TSC).

**Data Protection Overhead:** The storage capacity required to implement the selected level of data protection.

**Required Storage:** The amount of Configured Storage Capacity required to implement the Addressable Storage Configuration, excluding the storage required for the three ASUs.

**Global Storage Overhead:** The amount of Physical Storage Capacity that is required for storage subsystem use and unavailable for use by application programs.

**Total Unused Storage:** The amount of storage capacity available for use by application programs but not included in the Total ASU Capacity.

## SPC-1 Data Protection Levels

**Protected 1:** The single point of failure of any *storage device* in the configuration will not result in permanent loss of access to or integrity of the SPC-1 Data Repository.

**Protected 2:** The single point of failure of any *component* in the configuration will not result in permanent loss of access to or integrity of the SPC-1 Data Repository.

## SPC-1 Test Execution Definitions

**Average Response Time:** The sum of the Response Times for all Measured I/O Requests divided by the total number of Measured I/O Requests.

**Completed I/O Request:** An I/O Request with a Start Time and a Completion Time (see “I/O Completion Types” below).

**Completion Time:** The time recorded by the Workload Generator when an I/O Request is satisfied by the TSC as signaled by System Software.

**Data Rate:** The data transferred in all Measured I/O Requests in an SPC-1 Test Run divided by the length of the Test Run in seconds.

**Expected I/O Count:** For any given I/O Stream and Test Phase, the product of 50 times the BSU level, the duration of the Test Phase in seconds, and the Intensity Multiplier for that I/O Stream.

**Failed I/O Request:** Any I/O Request issued by the Workload Generator that could not be completed or was signaled as failed by System Software. A Failed I/O Request has no Completion Time (see “I/O Completion Types” below).

**I/O Request Throughput:** The total number of Measured I/O requests in an SPC-1 Test Run divided by the duration of the Measurement Interval in seconds.

**In-Flight I/O Request:** An I/O Request issued by the I/O Command Generator to the TSC that has a recorded Start Time, but does not complete within the Measurement Interval (see “I/O Completion Types” below).

**Measured I/O Request:** A Completed I/O Request with a Completion Time occurring within the Measurement Interval (see “I/O Completion Types” below).

**Measured Intensity Multiplier:** The percentage of all Measured I/O Requests that were issued by a given I/O Stream.

**Measurement Interval:** The finite and contiguous time period, after the TSC has reached Steady State, when data is collected by a Test Sponsor to generate an SPC-1 test result or support an SPC-1 test result.

**Ramp-Up:** The time required for the Benchmark Configuration (BC) to produce Steady State throughput after the Workload Generator begins submitting I/O Requests to the TSC for execution.

**Ramp-Down:** The time required for the BC to complete all I/O Requests issued by the Workload Generator. The Ramp-Down period begins when the Workload Generator ceases to issue new I/O Requests to the TSC.

**Response Time:** The Response Time of a Measured I/O Request is its Completion Time minus its Start Time.

**Start Time:** The time recorded by the Workload Generator when an I/O Request is submitted, by the Workload Generator, to the System Software for execution on the Tested Storage Configuration (TSC).

**Start-Up:** The period that begins after the Workload Generator starts to submit I/O requests to the TSC and ends at the beginning of the Measurement Interval.

**Shut-Down:** The period between the end of the Measurement Interval and the time when all I/O Requests issued by the Workload Generator have completed or failed.

**Steady State:** The consistent and sustainable throughput of the TSC. During this period the load presented to the TSC by the Workload Generator is constant.

**Test:** A collection of Test Phases and or Test Runs sharing a common objective.

**Test Run:** The execution of SPC-1 for the purpose of producing or supporting an SPC-1 test result. SPC-1 Test Runs may have a finite and measured Ramp-Up period, Start-Up period, Shut-Down period, and Ramp-Down period as illustrated in the “SPC-1 Test Run Components” below. All SPC-1 Test Runs shall have a Steady State period and a Measurement Interval.

**Test Phase:** A collection of one or more SPC-1 Test Runs sharing a common objective and intended to be run in a specific sequence.

### I/O Completion Types

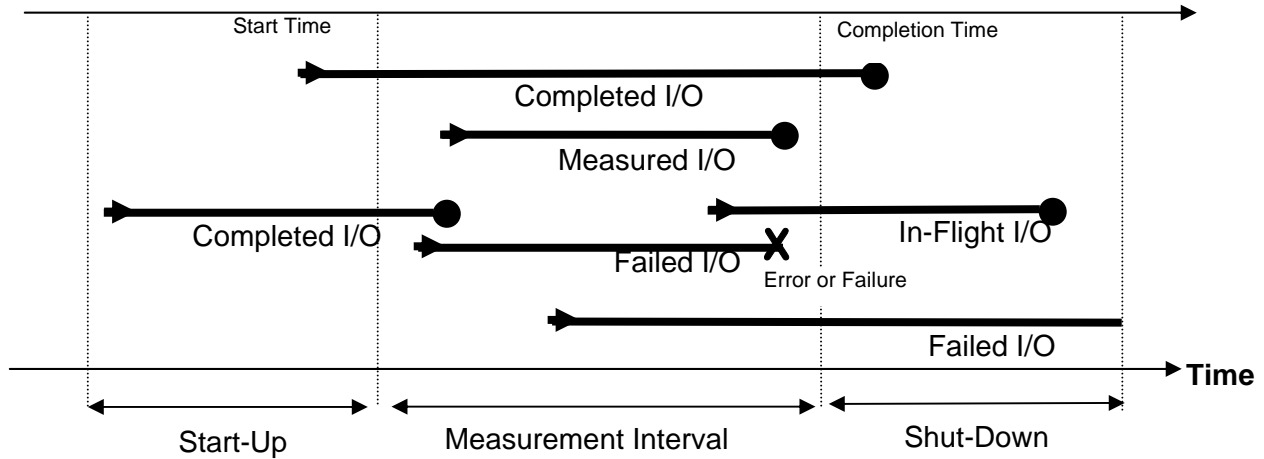

### SPC-1 Test Run Components

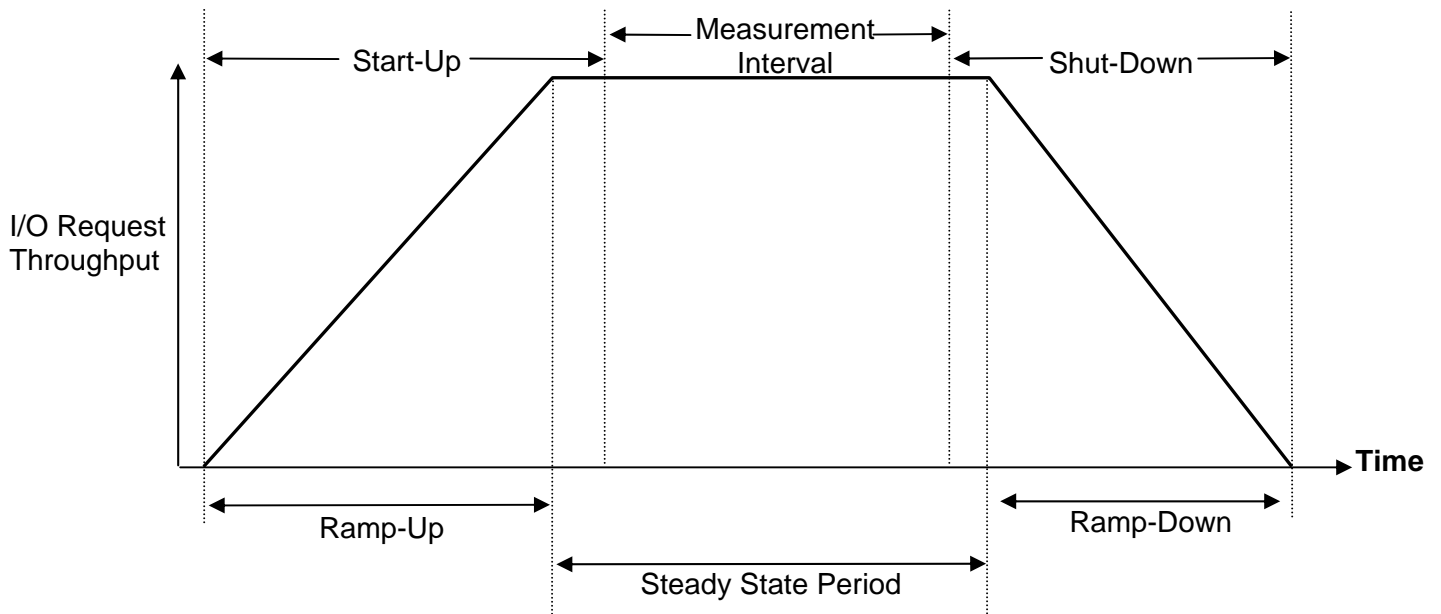

## APPENDIX B: CUSTOMER TUNABLE PARAMETERS AND OPTIONS

The following customer tunable parameters and options were changed from their default values for this benchmark. The **Set Parameter and Options** section of “Appendix C: Tested Storage Configuration (TSC) Creation” documents how those parameters and options were changed.

Parameter/Option <u><a href="#">set_monitoring</a></u>	Default Value	New Value
Disable performance monitor collection for the (8) performance measurement items listed in script.	<b>enable</b>	<b>disable</b>
<b>verify</b> (Online Verify) <i>This feature checks the medium in the drive. When it detects an error, the data on the error medium is verified from other drives.</i>	<b>enable</b>	<b>disable</b>
<b>detailedtrace</b> (Detailed Trace Mode) <i>This feature enhances logging by providing more detailed information if unusual hardware or software issues occur.</i>	<b>on</b>	<b>off</b>

Parameter/Option <u><a href="#">set_sysparms</a></u>	Default Value	New Value
<b>readwrite</b> : <i>This option setting allows multiple sequential streams to a given LUN trigger sequential reads and writes.</i>	<b>disable</b>	<b>-readwrite enable</b> <i>(set for ASU-3 only)</i>
<b>seqcount</b> (Count of Judgment Sequential) <i>This parameter determines how many previous I/Os of any stream must be in cache, including the I/O being executed, before triggering pre-fetch. A value of 1 will trigger pre-fetch for every I/O</i>	<b>3</b>	<b>0</b> (ASU-1 and ASU-2) <b>1</b> (ASU-3)
<b>criteria</b> (Prefetch Criteria) <i>This parameter determines the prefetch length. A value of <b>fixed</b> means that a fixed prefetch length is used.</i>	<b>base</b>	<b>fixed</b>
<b>dtystart</b> (Dirty Data Opportunity) <i>This defines the amount of Write Pending data allowed in cache before triggering a “Full Power” destage instead of it being a background task.</i>	<b>5</b>	<b>20</b>
<b>dtystop</b> (Dirty Data Stop Opportunity) <i>This defines the point at which “Full Power” destage ends.</i>	<b>5</b>	<b>10</b>
<b>loadbalancing</b> <i>This is a feature that enables balancing of controller CPU loads.</i>	<b>enable</b>	<b>disable</b>

## **APPENDIX C: TESTED STORAGE CONFIGURATION (TSC) CREATION**

The Storage Navigator Modular2 (SNM2) commands and scripts and Windows Diskpart scripts, which appear at the end of this section, were executed to create and configure the Tested Storage Configuration (TSC). Each SNM2 command and script was executed from a command window on the Host System where SNM2 was installed and configured for use. The **STONAVM\_HOME** environment variable was set to point to the home directory of the SNM2 installation so that the bin directory and command files could be found.

The SNM2 scripts were used to configure cache partitions, create RAID Groups and Logical Units, map LUs to the storage front-end ports, and set the parameters documented in Appendix B. Once these SNM2 scripts were successfully executed, the host system was rebooted. This enabled discovery of the storage LUNs on the host, which were then displayed as Windows disks in the Windows Disk Management console. After confirming the presence of 496 Windows disks, the Windows Diskpart command-line utility was used to prepare and configure the Windows disks into the striped logical volumes (LVs) that were used for the three ASUs. After the LVs were created, the TSC creation was complete.

### **1. Registration of the Unit**

The Hitachi Unified Storage 150 (HUS 150) was registered by executing the following commands in a command window on the Host System where SNM2 is installed:

```
set UNAME=(Your Unit Name)
auunitadd -unit %UNAME% -LAN -ctl0 (IP address of controller0) -ctl1 (IP address
of controller1)
Unit (Unit Name) has been registered.
```

### **2. Cache Partition Configuration**

By default, the cache memory of the HUS 150 has two cache partitions (CPs), CP0 and CP1. For this testing, the cache was divided into four CPs. First, the size of CP0 and CP1 (used for ASU-1 and ASU-2) was reduced. Then CP2 and CP3 were newly created (and used for ASU-3). These four actions were executed using the following four commands in a command window on the host system where SNM2 was installed. The required user responses to the command prompts are shown below.

First, the following two commands were executed to reduce the size of CP0 and CP1:

```
set UNAME=(Your Unit Name)
aucachept -unit %UNAME% -chg -pt 0 -ptsize 308
aucachept -unit %UNAME% -chg -pt 1 -ptsize 308
```

Following each of these **aucachept** commands was a series of prompts, listed below with their required responses:

The size of cache partition 0 (1) is changed into 3080MB.  
Do you want to continue processing? (y/n [n]): **y**  
The pair cache partition may be changed into "Auto". Please confirm pair cache partition after reboot.  
Do you want to continue processing? (y/n [n]): **y**  
In order to complete the changing, it is necessary to reboot the subsystem.  
When not restarting, the changing will be registered, but it will not become effective on the subsystem.  
Please execute this command again without restarting, if you want to continue setting of the cache partition.  
Do you restart the subsystem? (y/n [n]): **n**  
Are you sure you want to change the cache partition? (y/n [n]): **y**  
The cache partition has been changed successfully.  
Please restart the subsystem to enable the settings.

Then the two commands below were executed to create CP2 and CP3. The command prompts and user responses are listed below.

```
aucachept -unit %UNAME% -add -ptsize 250 -segsz 16 -ctl0
```

The reserved cache partition 2 in size 2500MB is set up to CTL0.  
Do you want to continue processing? (y/n [n]): **y**  
In order to complete the setting, it is necessary to reboot the subsystem.  
When not restarting, the setting will be registered, but it will not become effective on the subsystem.  
Please execute this command again without restarting, if you want to continue setting of the cache partition.  
Do you restart the subsystem? (y/n [n]): **n**  
Are you sure you want to set the cache partition? (y/n [n]): **y**  
The cache partition has been set successfully.  
Please restart the subsystem to enable the settings.

```
aucachept -unit %UNAME% -add -ptsize 250 -segsz 16 -ctl1
```

The reserved cache partition 3 in size 2500MB is set up to CTL1.  
Do you want to continue processing? (y/n [n]): **y**  
In order to complete the setting, it is necessary to reboot the subsystem.  
When not restarting, the setting will be registered, but it will not become effective on the subsystem.  
Please execute this command again without restarting, if you want to continue setting of the cache partition.  
Do you restart the subsystem? (y/n [n]): **y**  
Host will be unable to access the subsystem while restarting.....  
Do you agree with restarting? (y/n [n]): **y**  
Are you sure you want to execute? (y/n [n]): **y**  
Now restarting the subsystem. Start Time nn:nn:nn Time Required 7 - 25min.



### 3. RAID Group (RG) Creation

After the subsystem was restarted, there were 48 RAID Groups, RGs #0-47 (*8D+8D, RAID1+0*) created for ASU-1 and ASU-2 and 16 RAID Groups, RGs #48-63 (*4D+4D, RAID1+0*) created for ASU-3. These RAID Groups were created using the [RG Add](#) script.

### 4. Logical Unit (LU) Creation

In RGs #0-47, there were 10 logical units (LUs) created per RG for a total of 480 LUs. Of these, 240 LUs were used for ASU-1 and the remaining 240 LUs were used for ASU-2.

In RGs #48-63, there was one LU created per RG for a total of 16 LUs, which were used for ASU-3.

All LUs were created and their controller core ownerships assigned using the [LU Add](#) script.

### 5. Map LUs to Front-End Ports

Each front-end port was assigned 31 LUs as follows: 15 LUs for ASU-1, 15 LUs for ASU-2 and 1 LU for ASU-3.

The [LU Port Mapping](#) script was executed to map the LUs to the front-end ports.

### 6. Set Parameters and Options

Each customer tunable and option that was changed from its default value for the benchmark execution is described in “*Appendix B: Customer Tunable Parameters and Options*”.

The [set\\_monitoring](#) script disables performance monitor collection, trace and verification setting on the HUS 150.

The [set\\_sysparms](#) script sets performance tuning on the HUS 150.

### 7. Reboot the Host System

A reboot of the host system was then done to enable discovery of the LUNs on the host. After reboot, the LUNs appeared as Windows disks in the Windows Disk Management console.

### 8. Prepare Windows Disks for Logical Volume Creation

The Windows Diskpart utility was used to prepare the 496 Windows disks for use as logical volumes using the [Prepare Disks forLVs.bat](#) script. This script performs four actions: clear the read-only flags, bring the disks online, convert the disks from basic to dynamic, and convert the disks from MBR to GPT format.

### 9. Create Windows Striped Logical Volumes

Finally, the Windows logical volumes used for ASU-1, ASU-2, and ASU-3 were created by executing the [Create LVs.bat](#) script. This script creates 21 striped logical volumes (with drive letters E through Y) from the 496 Windows disks. For ASU-1 and ASU-2, there were ten LVs each, where each LV was striped across 24 disks. For ASU-3, there was one LV, striped across sixteen disks. As the LVs are created, there's a Windows dialog box that prompts for formatting:

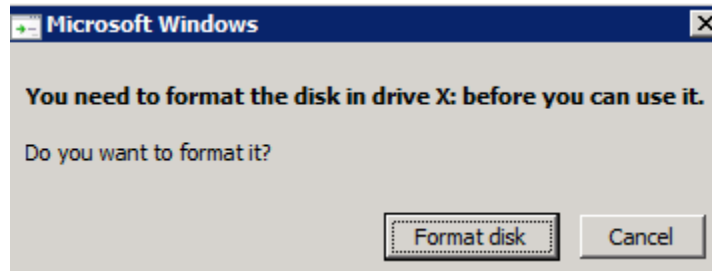

The "Cancel" button was clicked.

Upon completion of this script, the Windows logical volumes were ready for use, striped across storage LUNs according to the following table:

Windows Drive Letter	Storage LUN Numbers	SPC-1 ASU Detail
E:\	0, 10, 20, 30, 40, 50, 60, 70, 80, 90, 100, 110, 120, 130, 180, 190, 280, 290, 340, 350, 380, 390, 440, 450	ASU 1-1
F:\	1, 11, 21, 31, 41, 51, 61, 71, 81, 91, 101, 111, 121, 131, 181, 191, 281, 291, 341, 351, 381, 391, 441, 451	ASU 1-2
G:\	2, 12, 22, 32, 42, 52, 62, 72, 82, 92, 102, 112, 122, 132, 182, 192, 282, 292, 342, 352, 382, 392, 442, 452	ASU 1-3
H:\	3, 13, 23, 33, 43, 53, 63, 73, 83, 93, 103, 113, 123, 133, 183, 193, 283, 293, 343, 353, 383, 393, 443, 453	ASU 1-4
I:\	4, 14, 24, 34, 44, 54, 64, 74, 84, 94, 104, 114, 124, 134, 184, 194, 284, 294, 344, 354, 384, 394, 444, 454	ASU 1-5
J:\	140, 150, 160, 170, 200, 210, 220, 230, 240, 250, 260, 270, 300, 310, 320, 330, 360, 370, 400, 410, 420, 430, 460, 470	ASU 1-6
K:\	141, 151, 161, 171, 201, 211, 221, 231, 241, 251, 261, 271, 301, 311, 321, 331, 361, 371, 401, 411, 421, 431, 461, 471	ASU 1-7
L:\	142, 152, 162, 172, 202, 212, 222, 232, 242, 252, 262, 272, 302, 312, 322, 332, 362, 372, 402, 412, 422, 432, 462, 472	ASU 1-8

M:\	143, 153, 163, 173, 203, 213, 223, 233, 243, 253, 263, 273, 303, 313, 323, 333, 363, 373, 403, 413, 423, 433, 463, 473	ASU 1-9
N:\	144, 154, 164, 174, 204, 214, 224, 234, 244, 254, 264, 274, 304, 314, 324, 334, 364, 374, 404, 414, 424, 434, 464, 474	ASU 1-10
O:\	5, 15, 25, 35, 45, 55, 65, 75, 85, 95, 105, 115, 125, 135, 185, 195, 285, 295, 345, 355, 385, 395, 445, 455	ASU 2-1
P:\	6, 16, 26, 36, 46, 56, 66, 76, 86, 96, 106, 116, 126, 136, 186, 196, 286, 296, 346, 356, 386, 396, 446, 456	ASU 2-2
Q:\	7, 17, 27, 37, 47, 57, 67, 77, 87, 97, 107, 117, 127, 137, 187, 197, 287, 297, 347, 357, 387, 397, 447, 457	ASU 2-3
R:\	8, 18, 28, 38, 48, 58, 68, 78, 88, 98, 108, 118, 128, 138, 188, 198, 288, 298, 348, 358, 388, 398, 448, 458	ASU 2-4
S:\	9, 19, 29, 39, 49, 59, 69, 79, 89, 99, 109, 119, 129, 139, 189, 199, 289, 299, 349, 359, 389, 399, 449, 459	ASU 2-5
T:\	145, 155, 165, 175, 205, 215, 225, 235, 245, 255, 265, 275, 305, 315, 325, 335, 365, 375, 405, 415, 425, 435, 465, 475	ASU 2-6
U:\	146, 156, 166, 176, 206, 216, 226, 236, 246, 256, 266, 276, 306, 316, 326, 336, 366, 376, 406, 416, 426, 436, 466, 476	ASU 2-7
V:\	147, 157, 167, 177, 207, 217, 227, 237, 247, 257, 267, 277, 307, 317, 327, 337, 367, 377, 407, 417, 427, 437, 467, 477	ASU 2-8
W:\	148, 158, 168, 178, 208, 218, 228, 238, 248, 258, 268, 278, 308, 318, 328, 338, 368, 378, 408, 418, 428, 438, 468, 478	ASU 2-9
X:\	149, 159, 169, 179, 209, 219, 229, 239, 249, 259, 269, 279, 309, 319, 329, 339, 369, 379, 409, 419, 429, 439, 469, 479	ASU 2-10
Y:\	480 - 495	ASU 3-1

## TSC Creation/Configuration Scripts

### RG\_Add

```
aurgadd -unit %UNAME% -rg 0 -RAID10 -drive 0.0-0.15 -pnum 1
aurgadd -unit %UNAME% -rg 2 -RAID10 -drive 0.16-0.23 2.0-2.7 -pnum 1
aurgadd -unit %UNAME% -rg 4 -RAID10 -drive 2.8-2.23 -pnum 1
aurgadd -unit %UNAME% -rg 6 -RAID10 -drive 4.0-4.15 -pnum 1
aurgadd -unit %UNAME% -rg 8 -RAID10 -drive 4.16-4.23 6.0-6.7 -pnum 1
aurgadd -unit %UNAME% -rg 10 -RAID10 -drive 6.8-6.23 -pnum 1
aurgadd -unit %UNAME% -rg 12 -RAID10 -drive 8.0-8.15 -pnum 1
aurgadd -unit %UNAME% -rg 14 -RAID10 -drive 8.16-8.23 10.0-10.7 -pnum 1
aurgadd -unit %UNAME% -rg 16 -RAID10 -drive 10.8-10.23 -pnum 1
aurgadd -unit %UNAME% -rg 18 -RAID10 -drive 12.0-12.15 -pnum 1
aurgadd -unit %UNAME% -rg 20 -RAID10 -drive 12.16-12.23 14.0-14.7 -pnum 1
aurgadd -unit %UNAME% -rg 22 -RAID10 -drive 14.8-14.23 -pnum 1
aurgadd -unit %UNAME% -rg 24 -RAID10 -drive 16.0-16.15 -pnum 1
aurgadd -unit %UNAME% -rg 26 -RAID10 -drive 16.16-16.23 18.0-18.7 -pnum 1
aurgadd -unit %UNAME% -rg 28 -RAID10 -drive 18.8-18.23 -pnum 1
aurgadd -unit %UNAME% -rg 30 -RAID10 -drive 20.0-20.15 -pnum 1
aurgadd -unit %UNAME% -rg 32 -RAID10 -drive 20.16-20.23 22.0-22.7 -pnum 1
aurgadd -unit %UNAME% -rg 34 -RAID10 -drive 22.8-22.23 -pnum 1
aurgadd -unit %UNAME% -rg 36 -RAID10 -drive 24.0-24.15 -pnum 1
aurgadd -unit %UNAME% -rg 38 -RAID10 -drive 24.16-24.23 26.0-26.7 -pnum 1
aurgadd -unit %UNAME% -rg 1 -RAID10 -drive 1.0-1.15 -pnum 1
aurgadd -unit %UNAME% -rg 3 -RAID10 -drive 1.16-1.23 3.0-3.7 -pnum 1
aurgadd -unit %UNAME% -rg 5 -RAID10 -drive 3.8-3.23 -pnum 1
aurgadd -unit %UNAME% -rg 7 -RAID10 -drive 5.0-5.15 -pnum 1
aurgadd -unit %UNAME% -rg 9 -RAID10 -drive 5.16-5.23 7.0-7.7 -pnum 1
aurgadd -unit %UNAME% -rg 11 -RAID10 -drive 7.8-7.23 -pnum 1
aurgadd -unit %UNAME% -rg 13 -RAID10 -drive 9.0-9.15 -pnum 1
aurgadd -unit %UNAME% -rg 15 -RAID10 -drive 9.16-9.23 11.0-11.7 -pnum 1
aurgadd -unit %UNAME% -rg 17 -RAID10 -drive 11.8-11.23 -pnum 1
aurgadd -unit %UNAME% -rg 19 -RAID10 -drive 13.0-13.15 -pnum 1
aurgadd -unit %UNAME% -rg 21 -RAID10 -drive 13.16-13.23 15.0-15.7 -pnum 1
aurgadd -unit %UNAME% -rg 23 -RAID10 -drive 15.8-15.23 -pnum 1
aurgadd -unit %UNAME% -rg 25 -RAID10 -drive 17.0-17.15 -pnum 1
aurgadd -unit %UNAME% -rg 27 -RAID10 -drive 17.16-17.23 19.0-19.7 -pnum 1
aurgadd -unit %UNAME% -rg 29 -RAID10 -drive 19.8-19.23 -pnum 1
aurgadd -unit %UNAME% -rg 31 -RAID10 -drive 21.0-21.15 -pnum 1
aurgadd -unit %UNAME% -rg 33 -RAID10 -drive 21.16-21.23 23.0-23.7 -pnum 1
aurgadd -unit %UNAME% -rg 35 -RAID10 -drive 23.8-23.23 -pnum 1
aurgadd -unit %UNAME% -rg 37 -RAID10 -drive 25.0-25.15 -pnum 1
aurgadd -unit %UNAME% -rg 39 -RAID10 -drive 25.16-25.23 27.0-27.7 -pnum 1
aurgadd -unit %UNAME% -rg 40 -RAID10 -drive 26.8-26.23 -pnum 1
aurgadd -unit %UNAME% -rg 41 -RAID10 -drive 27.8-27.23 -pnum 1
aurgadd -unit %UNAME% -rg 42 -RAID10 -drive 28.0-28.15 -pnum 1
aurgadd -unit %UNAME% -rg 43 -RAID10 -drive 29.0-29.15 -pnum 1
aurgadd -unit %UNAME% -rg 44 -RAID10 -drive 28.16-28.23 30.0-30.7 -pnum 1
aurgadd -unit %UNAME% -rg 45 -RAID10 -drive 29.16-29.23 31.0-31.7 -pnum 1
aurgadd -unit %UNAME% -rg 46 -RAID10 -drive 30.8-30.23 -pnum 1
aurgadd -unit %UNAME% -rg 47 -RAID10 -drive 31.8-31.23 -pnum 1
aurgadd -unit %UNAME% -rg 48 -RAID10 -drive 32.0-32.7 -pnum 1
aurgadd -unit %UNAME% -rg 49 -RAID10 -drive 32.8-32.15 -pnum 1
aurgadd -unit %UNAME% -rg 50 -RAID10 -drive 32.16-32.23 -pnum 1
aurgadd -unit %UNAME% -rg 51 -RAID10 -drive 33.0-33.7 -pnum 1
aurgadd -unit %UNAME% -rg 52 -RAID10 -drive 33.8-33.15 -pnum 1
aurgadd -unit %UNAME% -rg 53 -RAID10 -drive 33.16-33.23 -pnum 1
aurgadd -unit %UNAME% -rg 54 -RAID10 -drive 34.0-34.7 -pnum 1
aurgadd -unit %UNAME% -rg 55 -RAID10 -drive 34.8-34.15 -pnum 1
aurgadd -unit %UNAME% -rg 56 -RAID10 -drive 34.16-34.23 -pnum 1
```

```
aurgadd -unit %UNAME% -rg 57 -RAID10 -drive 35.0-35.7 -pnum 1
aurgadd -unit %UNAME% -rg 58 -RAID10 -drive 35.8-35.15 -pnum 1
aurgadd -unit %UNAME% -rg 59 -RAID10 -drive 35.16-35.23 -pnum 1
aurgadd -unit %UNAME% -rg 60 -RAID10 -drive 36.0-36.7 -pnum 1
aurgadd -unit %UNAME% -rg 61 -RAID10 -drive 36.8-36.15 -pnum 1
aurgadd -unit %UNAME% -rg 62 -RAID10 -drive 37.0-37.7 -pnum 1
aurgadd -unit %UNAME% -rg 63 -RAID10 -drive 37.8-37.15 -pnum 1
```

## LU\_Add

```
for /L %%I IN ( 0, 1, 9) DO auluadd -unit %UNAME% -lu %%I -rg 0 -size 322121604 -
cachept 0 -noluformat
for /L %%I IN (10, 1,19) DO auluadd -unit %UNAME% -lu %%I -rg 1 -size 322121604 -
cachept 0 -noluformat
for /L %%I IN (20, 1,29) DO auluadd -unit %UNAME% -lu %%I -rg 2 -size 322121604 -
cachept 0 -noluformat
for /L %%I IN (30, 1,39) DO auluadd -unit %UNAME% -lu %%I -rg 3 -size 322121604 -
cachept 0 -noluformat
for /L %%I IN (40, 1,49) DO auluadd -unit %UNAME% -lu %%I -rg 4 -size 322121604 -
cachept 0 -noluformat
for /L %%I IN (50, 1,59) DO auluadd -unit %UNAME% -lu %%I -rg 5 -size 322121604 -
cachept 0 -noluformat

for /L %%I IN (60, 1,69) DO auluadd -unit %UNAME% -lu %%I -rg 6 -size 322121604 -
cachept 1 -noluformat
for /L %%I IN (70, 1,79) DO auluadd -unit %UNAME% -lu %%I -rg 7 -size 322121604 -
cachept 1 -noluformat
for /L %%I IN (80, 1,89) DO auluadd -unit %UNAME% -lu %%I -rg 8 -size 322121604 -
cachept 1 -noluformat
for /L %%I IN (90, 1,99) DO auluadd -unit %UNAME% -lu %%I -rg 9 -size 322121604 -
cachept 1 -noluformat
for /L %%I IN (100, 1,109) DO auluadd -unit %UNAME% -lu %%I -rg 10 -size 322121604 -
cachept 1 -noluformat
for /L %%I IN (110, 1,119) DO auluadd -unit %UNAME% -lu %%I -rg 11 -size 322121604 -
cachept 1 -noluformat

for /L %%I IN (120, 1,129) DO auluadd -unit %UNAME% -lu %%I -rg 12 -size 322121604 -
cachept 0 -noluformat
for /L %%I IN (130, 1,139) DO auluadd -unit %UNAME% -lu %%I -rg 13 -size 322121604 -
cachept 0 -noluformat
for /L %%I IN (140, 1,149) DO auluadd -unit %UNAME% -lu %%I -rg 14 -size 322121604 -
cachept 0 -noluformat
for /L %%I IN (150, 1,159) DO auluadd -unit %UNAME% -lu %%I -rg 15 -size 322121604 -
cachept 0 -noluformat
for /L %%I IN (160, 1,169) DO auluadd -unit %UNAME% -lu %%I -rg 16 -size 322121604 -
cachept 0 -noluformat
for /L %%I IN (170, 1,179) DO auluadd -unit %UNAME% -lu %%I -rg 17 -size 322121604 -
cachept 0 -noluformat

for /L %%I IN (180, 1,189) DO auluadd -unit %UNAME% -lu %%I -rg 18 -size 322121604 -
cachept 1 -noluformat
for /L %%I IN (190, 1,199) DO auluadd -unit %UNAME% -lu %%I -rg 19 -size 322121604 -
cachept 1 -noluformat
for /L %%I IN (200, 1,209) DO auluadd -unit %UNAME% -lu %%I -rg 20 -size 322121604 -
cachept 1 -noluformat
for /L %%I IN (210, 1,219) DO auluadd -unit %UNAME% -lu %%I -rg 21 -size 322121604 -
cachept 1 -noluformat
for /L %%I IN (220, 1,229) DO auluadd -unit %UNAME% -lu %%I -rg 22 -size 322121604 -
cachept 1 -noluformat
for /L %%I IN (230, 1,239) DO auluadd -unit %UNAME% -lu %%I -rg 23 -size 322121604 -
cachept 1 -noluformat
```

```
for /L %%I IN (240, 1,249) DO aлуadd -unit %UNAME% -lu %%I -rg 24 -size 322121604 -
cachept 0 -noluformat
for /L %%I IN (250, 1,259) DO aлуadd -unit %UNAME% -lu %%I -rg 25 -size 322121604 -
cachept 0 -noluformat
for /L %%I IN (260, 1,269) DO aлуadd -unit %UNAME% -lu %%I -rg 26 -size 322121604 -
cachept 0 -noluformat
for /L %%I IN (270, 1,279) DO aлуadd -unit %UNAME% -lu %%I -rg 27 -size 322121604 -
cachept 0 -noluformat

for /L %%I IN (280, 1,289) DO aлуadd -unit %UNAME% -lu %%I -rg 28 -size 322121604 -
cachept 0 -noluformat
for /L %%I IN (290, 1,299) DO aлуadd -unit %UNAME% -lu %%I -rg 29 -size 322121604 -
cachept 0 -noluformat
for /L %%I IN (300, 1,309) DO aлуadd -unit %UNAME% -lu %%I -rg 30 -size 322121604 -
cachept 1 -noluformat
for /L %%I IN (310, 1,319) DO aлуadd -unit %UNAME% -lu %%I -rg 31 -size 322121604 -
cachept 1 -noluformat

for /L %%I IN (320, 1,329) DO aлуadd -unit %UNAME% -lu %%I -rg 32 -size 322121604 -
cachept 1 -noluformat
for /L %%I IN (330, 1,339) DO aлуadd -unit %UNAME% -lu %%I -rg 33 -size 322121604 -
cachept 1 -noluformat
for /L %%I IN (340, 1,349) DO aлуadd -unit %UNAME% -lu %%I -rg 34 -size 322121604 -
cachept 1 -noluformat
for /L %%I IN (350, 1,359) DO aлуadd -unit %UNAME% -lu %%I -rg 35 -size 322121604 -
cachept 1 -noluformat
for /L %%I IN (360, 1,369) DO aлуadd -unit %UNAME% -lu %%I -rg 36 -size 322121604 -
cachept 0 -noluformat
for /L %%I IN (370, 1,379) DO aлуadd -unit %UNAME% -lu %%I -rg 37 -size 322121604 -
cachept 0 -noluformat
for /L %%I IN (380, 1,389) DO aлуadd -unit %UNAME% -lu %%I -rg 38 -size 322121604 -
cachept 0 -noluformat
for /L %%I IN (390, 1,399) DO aлуadd -unit %UNAME% -lu %%I -rg 39 -size 322121604 -
cachept 0 -noluformat

for /L %%I in (400, 1,409) DO aлуadd -unit %UNAME% -lu %%I -rg 40 -size 322121604 -
cachept 0 -noluformat
for /L %%I IN (410, 1,419) DO aлуadd -unit %UNAME% -lu %%I -rg 41 -size 322121604 -
cachept 0 -noluformat
for /L %%I IN (420, 1,429) DO aлуadd -unit %UNAME% -lu %%I -rg 42 -size 322121604 -
cachept 1 -noluformat
for /L %%I IN (430, 1,439) DO aлуadd -unit %UNAME% -lu %%I -rg 43 -size 322121604 -
cachept 1 -noluformat
for /L %%I IN (440, 1,449) DO aлуadd -unit %UNAME% -lu %%I -rg 44 -size 322121604 -
cachept 1 -noluformat
for /L %%I IN (450, 1,459) DO aлуadd -unit %UNAME% -lu %%I -rg 45 -size 322121604 -
cachept 1 -noluformat
for /L %%I IN (460, 1,469) DO aлуadd -unit %UNAME% -lu %%I -rg 46 -size 322121604 -
cachept 1 -noluformat
for /L %%I IN (470, 1,479) DO aлуadd -unit %UNAME% -lu %%I -rg 47 -size 322121604 -
cachept 1 -noluformat

aлуadd -unit %UNAME% -lu 480 -rg 48 -size 2227155558 -stripesize 512 -cachept 2
aлуadd -unit %UNAME% -lu 481 -rg 49 -size 2227155558 -stripesize 512 -cachept 2
aлуadd -unit %UNAME% -lu 482 -rg 50 -size 2227155558 -stripesize 512 -cachept 2
aлуadd -unit %UNAME% -lu 483 -rg 51 -size 2227155558 -stripesize 512 -cachept 2
aлуadd -unit %UNAME% -lu 484 -rg 52 -size 2227155558 -stripesize 512 -cachept 2
aлуadd -unit %UNAME% -lu 485 -rg 53 -size 2227155558 -stripesize 512 -cachept 2
aлуadd -unit %UNAME% -lu 486 -rg 54 -size 2227155558 -stripesize 512 -cachept 3
```

```
au luadd -unit %UNAME% -lu 487 -rg 55 -size 2227155558 -stripesize 512 -cachept 3

au luadd -unit %UNAME% -lu 488 -rg 56 -size 2227155558 -stripesize 512 -cachept 3
au luadd -unit %UNAME% -lu 489 -rg 57 -size 2227155558 -stripesize 512 -cachept 3
au luadd -unit %UNAME% -lu 490 -rg 58 -size 2227155558 -stripesize 512 -cachept 3
au luadd -unit %UNAME% -lu 491 -rg 59 -size 2227155558 -stripesize 512 -cachept 3
au luadd -unit %UNAME% -lu 492 -rg 60 -size 2227155558 -stripesize 512 -cachept 2
au luadd -unit %UNAME% -lu 493 -rg 61 -size 2227155558 -stripesize 512 -cachept 3
au luadd -unit %UNAME% -lu 494 -rg 62 -size 2227155558 -stripesize 512 -cachept 2
au luadd -unit %UNAME% -lu 495 -rg 63 -size 2227155558 -stripesize 512 -cachept 3

for /L %%n in (0,1,9) DO autuningluown -unit %UNAME% -set -lu %%n -ctl0 -coreX
for /L %%n in (20,1,29) DO autuningluown -unit %UNAME% -set -lu %%n -ctl0 -coreX

for /L %%n in (40,1,49) DO autuningluown -unit %UNAME% -set -lu %%n -ctl0 -coreX
for /L %%n in (120,1,129) DO autuningluown -unit %UNAME% -set -lu %%n -ctl0 -coreX
for /L %%n in (140,1,149) DO autuningluown -unit %UNAME% -set -lu %%n -ctl0 -coreX

for /L %%n in (160,1,169) DO autuningluown -unit %UNAME% -set -lu %%n -ctl0 -coreX
for /L %%n in (240,1,249) DO autuningluown -unit %UNAME% -set -lu %%n -ctl0 -coreX
for /L %%n in (260,1,269) DO autuningluown -unit %UNAME% -set -lu %%n -ctl0 -coreX

for /L %%n in (280,1,289) DO autuningluown -unit %UNAME% -set -lu %%n -ctl0 -coreX
for /L %%n in (360,1,369) DO autuningluown -unit %UNAME% -set -lu %%n -ctl0 -coreX

for /L %%n in (380,1,389) DO autuningluown -unit %UNAME% -set -lu %%n -ctl0 -coreX
for /L %%n in (400,1,409) DO autuningluown -unit %UNAME% -set -lu %%n -ctl0 -coreX

for /L %%n in (60,1,69) DO autuningluown -unit %UNAME% -set -lu %%n -ctl1 -coreX
for /L %%n in (80,1,89) DO autuningluown -unit %UNAME% -set -lu %%n -ctl1 -coreX
for /L %%n in (100,1,109) DO autuningluown -unit %UNAME% -set -lu %%n -ctl1 -coreX

for /L %%n in (180,1,189) DO autuningluown -unit %UNAME% -set -lu %%n -ctl1 -coreX
for /L %%n in (200,1,209) DO autuningluown -unit %UNAME% -set -lu %%n -ctl1 -coreX
for /L %%n in (220,1,229) DO autuningluown -unit %UNAME% -set -lu %%n -ctl1 -coreX

for /L %%n in (300,1,309) DO autuningluown -unit %UNAME% -set -lu %%n -ctl1 -coreX
for /L %%n in (320,1,329) DO autuningluown -unit %UNAME% -set -lu %%n -ctl1 -coreX
for /L %%n in (340,1,349) DO autuningluown -unit %UNAME% -set -lu %%n -ctl1 -coreX
for /L %%n in (420,1,429) DO autuningluown -unit %UNAME% -set -lu %%n -ctl1 -coreX

for /L %%n in (440,1,449) DO autuningluown -unit %UNAME% -set -lu %%n -ctl1 -coreX
for /L %%n in (460,1,469) DO autuningluown -unit %UNAME% -set -lu %%n -ctl1 -coreX

for /L %%n in (10,1,19) DO autuningluown -unit %UNAME% -set -lu %%n -ctl0 -coreY
for /L %%n in (30,1,39) DO autuningluown -unit %UNAME% -set -lu %%n -ctl0 -coreY
for /L %%n in (50,1,59) DO autuningluown -unit %UNAME% -set -lu %%n -ctl0 -coreY

for /L %%n in (130,1,139) DO autuningluown -unit %UNAME% -set -lu %%n -ctl0 -coreY
for /L %%n in (150,1,159) DO autuningluown -unit %UNAME% -set -lu %%n -ctl0 -coreY
for /L %%n in (170,1,179) DO autuningluown -unit %UNAME% -set -lu %%n -ctl0 -coreY

for /L %%n in (250,1,259) DO autuningluown -unit %UNAME% -set -lu %%n -ctl0 -coreY
for /L %%n in (270,1,279) DO autuningluown -unit %UNAME% -set -lu %%n -ctl0 -coreY
for /L %%n in (290,1,299) DO autuningluown -unit %UNAME% -set -lu %%n -ctl0 -coreY
```

```
for /L %%n in (370,1,379) DO autuningluown -unit %UNAME% -set -lu %%n -ctl0 -coreY
for /L %%n in (390,1,399) DO autuningluown -unit %UNAME% -set -lu %%n -ctl0 -coreY
for /L %%n in (410,1,419) DO autuningluown -unit %UNAME% -set -lu %%n -ctl0 -coreY

for /L %%n in (70,1,79) DO autuningluown -unit %UNAME% -set -lu %%n -ctl1 -coreY
for /L %%n in (90,1,99) DO autuningluown -unit %UNAME% -set -lu %%n -ctl1 -coreY
for /L %%n in (110,1,119) DO autuningluown -unit %UNAME% -set -lu %%n -ctl1 -coreY

for /L %%n in (190,1,199) DO autuningluown -unit %UNAME% -set -lu %%n -ctl1 -coreY
for /L %%n in (210,1,219) DO autuningluown -unit %UNAME% -set -lu %%n -ctl1 -coreY
for /L %%n in (230,1,239) DO autuningluown -unit %UNAME% -set -lu %%n -ctl1 -coreY

for /L %%n in (310,1,319) DO autuningluown -unit %UNAME% -set -lu %%n -ctl1 -coreY
for /L %%n in (330,1,339) DO autuningluown -unit %UNAME% -set -lu %%n -ctl1 -coreY
for /L %%n in (350,1,359) DO autuningluown -unit %UNAME% -set -lu %%n -ctl1 -coreY

for /L %%n in (430,1,439) DO autuningluown -unit %UNAME% -set -lu %%n -ctl1 -coreY
for /L %%n in (450,1,459) DO autuningluown -unit %UNAME% -set -lu %%n -ctl1 -coreY
for /L %%n in (470,1,479) DO autuningluown -unit %UNAME% -set -lu %%n -ctl1 -coreY
```

```
autuningluown -unit %UNAME% -set -lu 480 -ctl0 -coreX
autuningluown -unit %UNAME% -set -lu 481 -ctl0 -coreX
autuningluown -unit %UNAME% -set -lu 482 -ctl0 -coreX
```

```
autuningluown -unit %UNAME% -set -lu 483 -ctl0 -coreY
autuningluown -unit %UNAME% -set -lu 484 -ctl0 -coreY
autuningluown -unit %UNAME% -set -lu 485 -ctl0 -coreY
```

```
autuningluown -unit %UNAME% -set -lu 486 -ctl1 -coreX
autuningluown -unit %UNAME% -set -lu 487 -ctl1 -coreX
autuningluown -unit %UNAME% -set -lu 488 -ctl1 -coreX
```

```
autuningluown -unit %UNAME% -set -lu 489 -ctl1 -coreY
autuningluown -unit %UNAME% -set -lu 490 -ctl1 -coreY
autuningluown -unit %UNAME% -set -lu 491 -ctl1 -coreY
```

```
autuningluown -unit %UNAME% -set -lu 492 -ctl0 -coreX
autuningluown -unit %UNAME% -set -lu 493 -ctl1 -coreX
autuningluown -unit %UNAME% -set -lu 494 -ctl0 -coreY
autuningluown -unit %UNAME% -set -lu 495 -ctl1 -coreY
```

```
for /L %I IN (480, 1, 495) DO auformat -unit %UNAME% -lu %I
for /L %I IN ( 0, 10, 479) DO auformat -unit %UNAME% -lu %I
for /L %I IN ( 1, 10, 479) DO auformat -unit %UNAME% -lu %I
for /L %I IN ( 2, 10, 479) DO auformat -unit %UNAME% -lu %I
for /L %I IN ( 3, 10, 479) DO auformat -unit %UNAME% -lu %I
for /L %I IN ( 4, 10, 479) DO auformat -unit %UNAME% -lu %I
for /L %I IN ( 5, 10, 479) DO auformat -unit %UNAME% -lu %I
for /L %I IN ( 6, 10, 479) DO auformat -unit %UNAME% -lu %I
for /L %I IN ( 7, 10, 479) DO auformat -unit %UNAME% -lu %I
for /L %I IN ( 8, 10, 479) DO auformat -unit %UNAME% -lu %I
for /L %I IN ( 9, 10, 479) DO auformat -unit %UNAME% -lu %I
```

## LU\_Port\_Mapping

```
auhgmap -unit %UNAME% -MappingMode off
auhgmap -unit %UNAME% -MappingMode on
```



```
auhgmap -unit %UNAME% -add 0 A 0 0 0
auhgmap -unit %UNAME% -add 0 A 0 1 1
auhgmap -unit %UNAME% -add 0 A 0 2 2
auhgmap -unit %UNAME% -add 0 A 0 3 3
auhgmap -unit %UNAME% -add 0 A 0 4 4
auhgmap -unit %UNAME% -add 0 A 0 5 5
auhgmap -unit %UNAME% -add 0 A 0 6 6
auhgmap -unit %UNAME% -add 0 A 0 7 7
auhgmap -unit %UNAME% -add 0 A 0 8 8
auhgmap -unit %UNAME% -add 0 A 0 9 9
auhgmap -unit %UNAME% -add 0 A 0 10 140
auhgmap -unit %UNAME% -add 0 A 0 11 141
auhgmap -unit %UNAME% -add 0 A 0 12 142
auhgmap -unit %UNAME% -add 0 A 0 13 143
auhgmap -unit %UNAME% -add 0 A 0 14 144
auhgmap -unit %UNAME% -add 0 A 0 15 145
auhgmap -unit %UNAME% -add 0 A 0 16 146
auhgmap -unit %UNAME% -add 0 A 0 17 147
auhgmap -unit %UNAME% -add 0 A 0 18 148
auhgmap -unit %UNAME% -add 0 A 0 19 149

auhgmap -unit %UNAME% -add 0 A 0 20 280
auhgmap -unit %UNAME% -add 0 A 0 21 281
auhgmap -unit %UNAME% -add 0 A 0 22 282
auhgmap -unit %UNAME% -add 0 A 0 23 283
auhgmap -unit %UNAME% -add 0 A 0 24 284
auhgmap -unit %UNAME% -add 0 A 0 25 285
auhgmap -unit %UNAME% -add 0 A 0 26 286
auhgmap -unit %UNAME% -add 0 A 0 27 287
auhgmap -unit %UNAME% -add 0 A 0 28 288
auhgmap -unit %UNAME% -add 0 A 0 29 289

auhgmap -unit %UNAME% -add 0 B 0 0 20
auhgmap -unit %UNAME% -add 0 B 0 1 21
auhgmap -unit %UNAME% -add 0 B 0 2 22
auhgmap -unit %UNAME% -add 0 B 0 3 23
auhgmap -unit %UNAME% -add 0 B 0 4 24
auhgmap -unit %UNAME% -add 0 B 0 5 25
auhgmap -unit %UNAME% -add 0 B 0 6 26
auhgmap -unit %UNAME% -add 0 B 0 7 27
auhgmap -unit %UNAME% -add 0 B 0 8 28
auhgmap -unit %UNAME% -add 0 B 0 9 29
auhgmap -unit %UNAME% -add 0 B 0 10 160
auhgmap -unit %UNAME% -add 0 B 0 11 161
auhgmap -unit %UNAME% -add 0 B 0 12 162
auhgmap -unit %UNAME% -add 0 B 0 13 163
auhgmap -unit %UNAME% -add 0 B 0 14 164
auhgmap -unit %UNAME% -add 0 B 0 15 165
auhgmap -unit %UNAME% -add 0 B 0 16 166
auhgmap -unit %UNAME% -add 0 B 0 17 167
auhgmap -unit %UNAME% -add 0 B 0 18 168
auhgmap -unit %UNAME% -add 0 B 0 19 169

auhgmap -unit %UNAME% -add 0 B 0 20 360
auhgmap -unit %UNAME% -add 0 B 0 21 361
auhgmap -unit %UNAME% -add 0 B 0 22 362
auhgmap -unit %UNAME% -add 0 B 0 23 363
auhgmap -unit %UNAME% -add 0 B 0 24 364
auhgmap -unit %UNAME% -add 0 B 0 25 365
auhgmap -unit %UNAME% -add 0 B 0 26 366
auhgmap -unit %UNAME% -add 0 B 0 27 367
auhgmap -unit %UNAME% -add 0 B 0 28 368
```

auhgmap -unit %UNAME% -add 0 B 0 29 369

auhgmap -unit %UNAME% -add 0 C 0 0 40  
auhgmap -unit %UNAME% -add 0 C 0 1 41  
auhgmap -unit %UNAME% -add 0 C 0 2 42  
auhgmap -unit %UNAME% -add 0 C 0 3 43  
auhgmap -unit %UNAME% -add 0 C 0 4 44  
auhgmap -unit %UNAME% -add 0 C 0 5 45  
auhgmap -unit %UNAME% -add 0 C 0 6 46  
auhgmap -unit %UNAME% -add 0 C 0 7 47  
auhgmap -unit %UNAME% -add 0 C 0 8 48  
auhgmap -unit %UNAME% -add 0 C 0 9 49  
auhgmap -unit %UNAME% -add 0 C 0 10 240  
auhgmap -unit %UNAME% -add 0 C 0 11 241  
auhgmap -unit %UNAME% -add 0 C 0 12 242  
auhgmap -unit %UNAME% -add 0 C 0 13 243  
auhgmap -unit %UNAME% -add 0 C 0 14 244  
auhgmap -unit %UNAME% -add 0 C 0 15 245  
auhgmap -unit %UNAME% -add 0 C 0 16 246  
auhgmap -unit %UNAME% -add 0 C 0 17 247  
auhgmap -unit %UNAME% -add 0 C 0 18 248  
auhgmap -unit %UNAME% -add 0 C 0 19 249

auhgmap -unit %UNAME% -add 0 C 0 20 380  
auhgmap -unit %UNAME% -add 0 C 0 21 381  
auhgmap -unit %UNAME% -add 0 C 0 22 382  
auhgmap -unit %UNAME% -add 0 C 0 23 383  
auhgmap -unit %UNAME% -add 0 C 0 24 384  
auhgmap -unit %UNAME% -add 0 C 0 25 385  
auhgmap -unit %UNAME% -add 0 C 0 26 386  
auhgmap -unit %UNAME% -add 0 C 0 27 387  
auhgmap -unit %UNAME% -add 0 C 0 28 388  
auhgmap -unit %UNAME% -add 0 C 0 29 389

auhgmap -unit %UNAME% -add 0 D 0 0 120  
auhgmap -unit %UNAME% -add 0 D 0 1 121  
auhgmap -unit %UNAME% -add 0 D 0 2 122  
auhgmap -unit %UNAME% -add 0 D 0 3 123  
auhgmap -unit %UNAME% -add 0 D 0 4 124  
auhgmap -unit %UNAME% -add 0 D 0 5 125  
auhgmap -unit %UNAME% -add 0 D 0 6 126  
auhgmap -unit %UNAME% -add 0 D 0 7 127  
auhgmap -unit %UNAME% -add 0 D 0 8 128  
auhgmap -unit %UNAME% -add 0 D 0 9 129  
auhgmap -unit %UNAME% -add 0 D 0 10 260  
auhgmap -unit %UNAME% -add 0 D 0 11 261  
auhgmap -unit %UNAME% -add 0 D 0 12 262  
auhgmap -unit %UNAME% -add 0 D 0 13 263  
auhgmap -unit %UNAME% -add 0 D 0 14 264  
auhgmap -unit %UNAME% -add 0 D 0 15 265  
auhgmap -unit %UNAME% -add 0 D 0 16 266  
auhgmap -unit %UNAME% -add 0 D 0 17 267  
auhgmap -unit %UNAME% -add 0 D 0 18 268  
auhgmap -unit %UNAME% -add 0 D 0 19 269

auhgmap -unit %UNAME% -add 0 D 0 20 400  
auhgmap -unit %UNAME% -add 0 D 0 21 401  
auhgmap -unit %UNAME% -add 0 D 0 22 402  
auhgmap -unit %UNAME% -add 0 D 0 23 403  
auhgmap -unit %UNAME% -add 0 D 0 24 404  
auhgmap -unit %UNAME% -add 0 D 0 25 405

```
auhgmap -unit %UNAME% -add 0 D 0 26 406
auhgmap -unit %UNAME% -add 0 D 0 27 407
auhgmap -unit %UNAME% -add 0 D 0 28 408
auhgmap -unit %UNAME% -add 0 D 0 29 409

auhgmap -unit %UNAME% -add 0 E 0 0 10
auhgmap -unit %UNAME% -add 0 E 0 1 11
auhgmap -unit %UNAME% -add 0 E 0 2 12
auhgmap -unit %UNAME% -add 0 E 0 3 13
auhgmap -unit %UNAME% -add 0 E 0 4 14
auhgmap -unit %UNAME% -add 0 E 0 5 15
auhgmap -unit %UNAME% -add 0 E 0 6 16
auhgmap -unit %UNAME% -add 0 E 0 7 17
auhgmap -unit %UNAME% -add 0 E 0 8 18
auhgmap -unit %UNAME% -add 0 E 0 9 19
auhgmap -unit %UNAME% -add 0 E 0 10 150
auhgmap -unit %UNAME% -add 0 E 0 11 151
auhgmap -unit %UNAME% -add 0 E 0 12 152
auhgmap -unit %UNAME% -add 0 E 0 13 153
auhgmap -unit %UNAME% -add 0 E 0 14 154
auhgmap -unit %UNAME% -add 0 E 0 15 155
auhgmap -unit %UNAME% -add 0 E 0 16 156
auhgmap -unit %UNAME% -add 0 E 0 17 157
auhgmap -unit %UNAME% -add 0 E 0 18 158
auhgmap -unit %UNAME% -add 0 E 0 19 159

auhgmap -unit %UNAME% -add 0 E 0 20 290
auhgmap -unit %UNAME% -add 0 E 0 21 291
auhgmap -unit %UNAME% -add 0 E 0 22 292
auhgmap -unit %UNAME% -add 0 E 0 23 293
auhgmap -unit %UNAME% -add 0 E 0 24 294
auhgmap -unit %UNAME% -add 0 E 0 25 295
auhgmap -unit %UNAME% -add 0 E 0 26 296
auhgmap -unit %UNAME% -add 0 E 0 27 297
auhgmap -unit %UNAME% -add 0 E 0 28 298
auhgmap -unit %UNAME% -add 0 E 0 29 299

auhgmap -unit %UNAME% -add 0 F 0 0 30
auhgmap -unit %UNAME% -add 0 F 0 1 31
auhgmap -unit %UNAME% -add 0 F 0 2 32
auhgmap -unit %UNAME% -add 0 F 0 3 33
auhgmap -unit %UNAME% -add 0 F 0 4 34
auhgmap -unit %UNAME% -add 0 F 0 5 35
auhgmap -unit %UNAME% -add 0 F 0 6 36
auhgmap -unit %UNAME% -add 0 F 0 7 37
auhgmap -unit %UNAME% -add 0 F 0 8 38
auhgmap -unit %UNAME% -add 0 F 0 9 39
auhgmap -unit %UNAME% -add 0 F 0 10 170
auhgmap -unit %UNAME% -add 0 F 0 11 171
auhgmap -unit %UNAME% -add 0 F 0 12 172
auhgmap -unit %UNAME% -add 0 F 0 13 173
auhgmap -unit %UNAME% -add 0 F 0 14 174
auhgmap -unit %UNAME% -add 0 F 0 15 175
auhgmap -unit %UNAME% -add 0 F 0 16 176
auhgmap -unit %UNAME% -add 0 F 0 17 177
auhgmap -unit %UNAME% -add 0 F 0 18 178
auhgmap -unit %UNAME% -add 0 F 0 19 179

auhgmap -unit %UNAME% -add 0 F 0 20 370
auhgmap -unit %UNAME% -add 0 F 0 21 371
auhgmap -unit %UNAME% -add 0 F 0 22 372
auhgmap -unit %UNAME% -add 0 F 0 23 373
```

```
auhgmap -unit %UNAME% -add 0 F 0 24 374
auhgmap -unit %UNAME% -add 0 F 0 25 375
auhgmap -unit %UNAME% -add 0 F 0 26 376
auhgmap -unit %UNAME% -add 0 F 0 27 377
auhgmap -unit %UNAME% -add 0 F 0 28 378
auhgmap -unit %UNAME% -add 0 F 0 29 379
```

```
auhgmap -unit %UNAME% -add 0 G 0 0 50
auhgmap -unit %UNAME% -add 0 G 0 1 51
auhgmap -unit %UNAME% -add 0 G 0 2 52
auhgmap -unit %UNAME% -add 0 G 0 3 53
auhgmap -unit %UNAME% -add 0 G 0 4 54
auhgmap -unit %UNAME% -add 0 G 0 5 55
auhgmap -unit %UNAME% -add 0 G 0 6 56
auhgmap -unit %UNAME% -add 0 G 0 7 57
auhgmap -unit %UNAME% -add 0 G 0 8 58
auhgmap -unit %UNAME% -add 0 G 0 9 59
auhgmap -unit %UNAME% -add 0 G 0 10 250
auhgmap -unit %UNAME% -add 0 G 0 11 251
auhgmap -unit %UNAME% -add 0 G 0 12 252
auhgmap -unit %UNAME% -add 0 G 0 13 253
auhgmap -unit %UNAME% -add 0 G 0 14 254
auhgmap -unit %UNAME% -add 0 G 0 15 255
auhgmap -unit %UNAME% -add 0 G 0 16 256
auhgmap -unit %UNAME% -add 0 G 0 17 257
auhgmap -unit %UNAME% -add 0 G 0 18 258
auhgmap -unit %UNAME% -add 0 G 0 19 259
```

```
auhgmap -unit %UNAME% -add 0 G 0 20 390
auhgmap -unit %UNAME% -add 0 G 0 21 391
auhgmap -unit %UNAME% -add 0 G 0 22 392
auhgmap -unit %UNAME% -add 0 G 0 23 393
auhgmap -unit %UNAME% -add 0 G 0 24 394
auhgmap -unit %UNAME% -add 0 G 0 25 395
auhgmap -unit %UNAME% -add 0 G 0 26 396
auhgmap -unit %UNAME% -add 0 G 0 27 397
auhgmap -unit %UNAME% -add 0 G 0 28 398
auhgmap -unit %UNAME% -add 0 G 0 29 399
```

```
auhgmap -unit %UNAME% -add 0 H 0 0 130
auhgmap -unit %UNAME% -add 0 H 0 1 131
auhgmap -unit %UNAME% -add 0 H 0 2 132
auhgmap -unit %UNAME% -add 0 H 0 3 133
auhgmap -unit %UNAME% -add 0 H 0 4 134
auhgmap -unit %UNAME% -add 0 H 0 5 135
auhgmap -unit %UNAME% -add 0 H 0 6 136
auhgmap -unit %UNAME% -add 0 H 0 7 137
auhgmap -unit %UNAME% -add 0 H 0 8 138
auhgmap -unit %UNAME% -add 0 H 0 9 139
auhgmap -unit %UNAME% -add 0 H 0 10 270
auhgmap -unit %UNAME% -add 0 H 0 11 271
auhgmap -unit %UNAME% -add 0 H 0 12 272
auhgmap -unit %UNAME% -add 0 H 0 13 273
auhgmap -unit %UNAME% -add 0 H 0 14 274
auhgmap -unit %UNAME% -add 0 H 0 15 275
auhgmap -unit %UNAME% -add 0 H 0 16 276
auhgmap -unit %UNAME% -add 0 H 0 17 277
auhgmap -unit %UNAME% -add 0 H 0 18 278
auhgmap -unit %UNAME% -add 0 H 0 19 279
```

```
auhgmap -unit %UNAME% -add 0 H 0 20 410
auhgmap -unit %UNAME% -add 0 H 0 21 411
```

APPENDIX C:  
TESTED STORAGE CONFIGURATION (TSC) CREATION

auhgmap -unit %UNAME% -add 0 H 0 22 412  
auhgmap -unit %UNAME% -add 0 H 0 23 413  
auhgmap -unit %UNAME% -add 0 H 0 24 414  
auhgmap -unit %UNAME% -add 0 H 0 25 415  
auhgmap -unit %UNAME% -add 0 H 0 26 416  
auhgmap -unit %UNAME% -add 0 H 0 27 417  
auhgmap -unit %UNAME% -add 0 H 0 28 418  
auhgmap -unit %UNAME% -add 0 H 0 29 419

auhgmap -unit %UNAME% -add 1 A 0 0 60  
auhgmap -unit %UNAME% -add 1 A 0 1 61  
auhgmap -unit %UNAME% -add 1 A 0 2 62  
auhgmap -unit %UNAME% -add 1 A 0 3 63  
auhgmap -unit %UNAME% -add 1 A 0 4 64  
auhgmap -unit %UNAME% -add 1 A 0 5 65  
auhgmap -unit %UNAME% -add 1 A 0 6 66  
auhgmap -unit %UNAME% -add 1 A 0 7 67  
auhgmap -unit %UNAME% -add 1 A 0 8 68  
auhgmap -unit %UNAME% -add 1 A 0 9 69  
auhgmap -unit %UNAME% -add 1 A 0 10 200  
auhgmap -unit %UNAME% -add 1 A 0 11 201  
auhgmap -unit %UNAME% -add 1 A 0 12 202  
auhgmap -unit %UNAME% -add 1 A 0 13 203  
auhgmap -unit %UNAME% -add 1 A 0 14 204  
auhgmap -unit %UNAME% -add 1 A 0 15 205  
auhgmap -unit %UNAME% -add 1 A 0 16 206  
auhgmap -unit %UNAME% -add 1 A 0 17 207  
auhgmap -unit %UNAME% -add 1 A 0 18 208  
auhgmap -unit %UNAME% -add 1 A 0 19 209

auhgmap -unit %UNAME% -add 1 A 0 20 340  
auhgmap -unit %UNAME% -add 1 A 0 21 341  
auhgmap -unit %UNAME% -add 1 A 0 22 342  
auhgmap -unit %UNAME% -add 1 A 0 23 343  
auhgmap -unit %UNAME% -add 1 A 0 24 344  
auhgmap -unit %UNAME% -add 1 A 0 25 345  
auhgmap -unit %UNAME% -add 1 A 0 26 346  
auhgmap -unit %UNAME% -add 1 A 0 27 347  
auhgmap -unit %UNAME% -add 1 A 0 28 348  
auhgmap -unit %UNAME% -add 1 A 0 29 349

auhgmap -unit %UNAME% -add 1 B 0 0 80  
auhgmap -unit %UNAME% -add 1 B 0 1 81  
auhgmap -unit %UNAME% -add 1 B 0 2 82  
auhgmap -unit %UNAME% -add 1 B 0 3 83  
auhgmap -unit %UNAME% -add 1 B 0 4 84  
auhgmap -unit %UNAME% -add 1 B 0 5 85  
auhgmap -unit %UNAME% -add 1 B 0 6 86  
auhgmap -unit %UNAME% -add 1 B 0 7 87  
auhgmap -unit %UNAME% -add 1 B 0 8 88  
auhgmap -unit %UNAME% -add 1 B 0 9 89  
auhgmap -unit %UNAME% -add 1 B 0 10 220  
auhgmap -unit %UNAME% -add 1 B 0 11 221  
auhgmap -unit %UNAME% -add 1 B 0 12 222  
auhgmap -unit %UNAME% -add 1 B 0 13 223  
auhgmap -unit %UNAME% -add 1 B 0 14 224  
auhgmap -unit %UNAME% -add 1 B 0 15 225  
auhgmap -unit %UNAME% -add 1 B 0 16 226  
auhgmap -unit %UNAME% -add 1 B 0 17 227  
auhgmap -unit %UNAME% -add 1 B 0 18 228  
auhgmap -unit %UNAME% -add 1 B 0 19 229

```
auhgmap -unit %UNAME% -add 1 B 0 20 420
auhgmap -unit %UNAME% -add 1 B 0 21 421
auhgmap -unit %UNAME% -add 1 B 0 22 422
auhgmap -unit %UNAME% -add 1 B 0 23 423
auhgmap -unit %UNAME% -add 1 B 0 24 424
auhgmap -unit %UNAME% -add 1 B 0 25 425
auhgmap -unit %UNAME% -add 1 B 0 26 426
auhgmap -unit %UNAME% -add 1 B 0 27 427
auhgmap -unit %UNAME% -add 1 B 0 28 428
auhgmap -unit %UNAME% -add 1 B 0 29 429
```

```
auhgmap -unit %UNAME% -add 1 C 0 0 100
auhgmap -unit %UNAME% -add 1 C 0 1 101
auhgmap -unit %UNAME% -add 1 C 0 2 102
auhgmap -unit %UNAME% -add 1 C 0 3 103
auhgmap -unit %UNAME% -add 1 C 0 4 104
auhgmap -unit %UNAME% -add 1 C 0 5 105
auhgmap -unit %UNAME% -add 1 C 0 6 106
auhgmap -unit %UNAME% -add 1 C 0 7 107
auhgmap -unit %UNAME% -add 1 C 0 8 108
auhgmap -unit %UNAME% -add 1 C 0 9 109
auhgmap -unit %UNAME% -add 1 C 0 10 300
auhgmap -unit %UNAME% -add 1 C 0 11 301
auhgmap -unit %UNAME% -add 1 C 0 12 302
auhgmap -unit %UNAME% -add 1 C 0 13 303
auhgmap -unit %UNAME% -add 1 C 0 14 304
auhgmap -unit %UNAME% -add 1 C 0 15 305
auhgmap -unit %UNAME% -add 1 C 0 16 306
auhgmap -unit %UNAME% -add 1 C 0 17 307
auhgmap -unit %UNAME% -add 1 C 0 18 308
auhgmap -unit %UNAME% -add 1 C 0 19 309
```

```
auhgmap -unit %UNAME% -add 1 C 0 20 440
auhgmap -unit %UNAME% -add 1 C 0 21 441
auhgmap -unit %UNAME% -add 1 C 0 22 442
auhgmap -unit %UNAME% -add 1 C 0 23 443
auhgmap -unit %UNAME% -add 1 C 0 24 444
auhgmap -unit %UNAME% -add 1 C 0 25 445
auhgmap -unit %UNAME% -add 1 C 0 26 446
auhgmap -unit %UNAME% -add 1 C 0 27 447
auhgmap -unit %UNAME% -add 1 C 0 28 448
auhgmap -unit %UNAME% -add 1 C 0 29 449
```

```
auhgmap -unit %UNAME% -add 1 D 0 0 180
auhgmap -unit %UNAME% -add 1 D 0 1 181
auhgmap -unit %UNAME% -add 1 D 0 2 182
auhgmap -unit %UNAME% -add 1 D 0 3 183
auhgmap -unit %UNAME% -add 1 D 0 4 184
auhgmap -unit %UNAME% -add 1 D 0 5 185
auhgmap -unit %UNAME% -add 1 D 0 6 186
auhgmap -unit %UNAME% -add 1 D 0 7 187
auhgmap -unit %UNAME% -add 1 D 0 8 188
auhgmap -unit %UNAME% -add 1 D 0 9 189
auhgmap -unit %UNAME% -add 1 D 0 10 320
auhgmap -unit %UNAME% -add 1 D 0 11 321
auhgmap -unit %UNAME% -add 1 D 0 12 322
auhgmap -unit %UNAME% -add 1 D 0 13 323
auhgmap -unit %UNAME% -add 1 D 0 14 324
auhgmap -unit %UNAME% -add 1 D 0 15 325
auhgmap -unit %UNAME% -add 1 D 0 16 326
auhgmap -unit %UNAME% -add 1 D 0 17 327
```

APPENDIX C:  
TESTED STORAGE CONFIGURATION (TSC) CREATION

```
auhgmap -unit %UNAME% -add 1 D 0 18 328
auhgmap -unit %UNAME% -add 1 D 0 19 329

auhgmap -unit %UNAME% -add 1 D 0 20 460
auhgmap -unit %UNAME% -add 1 D 0 21 461
auhgmap -unit %UNAME% -add 1 D 0 22 462
auhgmap -unit %UNAME% -add 1 D 0 23 463
auhgmap -unit %UNAME% -add 1 D 0 24 464
auhgmap -unit %UNAME% -add 1 D 0 25 465
auhgmap -unit %UNAME% -add 1 D 0 26 466
auhgmap -unit %UNAME% -add 1 D 0 27 467
auhgmap -unit %UNAME% -add 1 D 0 28 468
auhgmap -unit %UNAME% -add 1 D 0 29 469

auhgmap -unit %UNAME% -add 1 E 0 0 70
auhgmap -unit %UNAME% -add 1 E 0 1 71
auhgmap -unit %UNAME% -add 1 E 0 2 72
auhgmap -unit %UNAME% -add 1 E 0 3 73
auhgmap -unit %UNAME% -add 1 E 0 4 74
auhgmap -unit %UNAME% -add 1 E 0 5 75
auhgmap -unit %UNAME% -add 1 E 0 6 76
auhgmap -unit %UNAME% -add 1 E 0 7 77
auhgmap -unit %UNAME% -add 1 E 0 8 78
auhgmap -unit %UNAME% -add 1 E 0 9 79
auhgmap -unit %UNAME% -add 1 E 0 10 210
auhgmap -unit %UNAME% -add 1 E 0 11 211
auhgmap -unit %UNAME% -add 1 E 0 12 212
auhgmap -unit %UNAME% -add 1 E 0 13 213
auhgmap -unit %UNAME% -add 1 E 0 14 214
auhgmap -unit %UNAME% -add 1 E 0 15 215
auhgmap -unit %UNAME% -add 1 E 0 16 216
auhgmap -unit %UNAME% -add 1 E 0 17 217
auhgmap -unit %UNAME% -add 1 E 0 18 218
auhgmap -unit %UNAME% -add 1 E 0 19 219

auhgmap -unit %UNAME% -add 1 E 0 20 350
auhgmap -unit %UNAME% -add 1 E 0 21 351
auhgmap -unit %UNAME% -add 1 E 0 22 352
auhgmap -unit %UNAME% -add 1 E 0 23 353
auhgmap -unit %UNAME% -add 1 E 0 24 354
auhgmap -unit %UNAME% -add 1 E 0 25 355
auhgmap -unit %UNAME% -add 1 E 0 26 356
auhgmap -unit %UNAME% -add 1 E 0 27 357
auhgmap -unit %UNAME% -add 1 E 0 28 358
auhgmap -unit %UNAME% -add 1 E 0 29 359

auhgmap -unit %UNAME% -add 1 F 0 0 90
auhgmap -unit %UNAME% -add 1 F 0 1 91
auhgmap -unit %UNAME% -add 1 F 0 2 92
auhgmap -unit %UNAME% -add 1 F 0 3 93
auhgmap -unit %UNAME% -add 1 F 0 4 94
auhgmap -unit %UNAME% -add 1 F 0 5 95
auhgmap -unit %UNAME% -add 1 F 0 6 96
auhgmap -unit %UNAME% -add 1 F 0 7 97
auhgmap -unit %UNAME% -add 1 F 0 8 98
auhgmap -unit %UNAME% -add 1 F 0 9 99
auhgmap -unit %UNAME% -add 1 F 0 10 230
auhgmap -unit %UNAME% -add 1 F 0 11 231
auhgmap -unit %UNAME% -add 1 F 0 12 232
auhgmap -unit %UNAME% -add 1 F 0 13 233
auhgmap -unit %UNAME% -add 1 F 0 14 234
```

auhgmap -unit %UNAME% -add 1 F 0 15 235  
auhgmap -unit %UNAME% -add 1 F 0 16 236  
auhgmap -unit %UNAME% -add 1 F 0 17 237  
auhgmap -unit %UNAME% -add 1 F 0 18 238  
auhgmap -unit %UNAME% -add 1 F 0 19 239

auhgmap -unit %UNAME% -add 1 F 0 20 430  
auhgmap -unit %UNAME% -add 1 F 0 21 431  
auhgmap -unit %UNAME% -add 1 F 0 22 432  
auhgmap -unit %UNAME% -add 1 F 0 23 433  
auhgmap -unit %UNAME% -add 1 F 0 24 434  
auhgmap -unit %UNAME% -add 1 F 0 25 435  
auhgmap -unit %UNAME% -add 1 F 0 26 436  
auhgmap -unit %UNAME% -add 1 F 0 27 437  
auhgmap -unit %UNAME% -add 1 F 0 28 438  
auhgmap -unit %UNAME% -add 1 F 0 29 439

auhgmap -unit %UNAME% -add 1 G 0 0 110  
auhgmap -unit %UNAME% -add 1 G 0 1 111  
auhgmap -unit %UNAME% -add 1 G 0 2 112  
auhgmap -unit %UNAME% -add 1 G 0 3 113  
auhgmap -unit %UNAME% -add 1 G 0 4 114  
auhgmap -unit %UNAME% -add 1 G 0 5 115  
auhgmap -unit %UNAME% -add 1 G 0 6 116  
auhgmap -unit %UNAME% -add 1 G 0 7 117  
auhgmap -unit %UNAME% -add 1 G 0 8 118  
auhgmap -unit %UNAME% -add 1 G 0 9 119  
auhgmap -unit %UNAME% -add 1 G 0 10 310  
auhgmap -unit %UNAME% -add 1 G 0 11 311  
auhgmap -unit %UNAME% -add 1 G 0 12 312  
auhgmap -unit %UNAME% -add 1 G 0 13 313  
auhgmap -unit %UNAME% -add 1 G 0 14 314  
auhgmap -unit %UNAME% -add 1 G 0 15 315  
auhgmap -unit %UNAME% -add 1 G 0 16 316  
auhgmap -unit %UNAME% -add 1 G 0 17 317  
auhgmap -unit %UNAME% -add 1 G 0 18 318  
auhgmap -unit %UNAME% -add 1 G 0 19 319

auhgmap -unit %UNAME% -add 1 G 0 20 450  
auhgmap -unit %UNAME% -add 1 G 0 21 451  
auhgmap -unit %UNAME% -add 1 G 0 22 452  
auhgmap -unit %UNAME% -add 1 G 0 23 453  
auhgmap -unit %UNAME% -add 1 G 0 24 454  
auhgmap -unit %UNAME% -add 1 G 0 25 455  
auhgmap -unit %UNAME% -add 1 G 0 26 456  
auhgmap -unit %UNAME% -add 1 G 0 27 457  
auhgmap -unit %UNAME% -add 1 G 0 28 458  
auhgmap -unit %UNAME% -add 1 G 0 29 459

auhgmap -unit %UNAME% -add 1 H 0 0 190  
auhgmap -unit %UNAME% -add 1 H 0 1 191  
auhgmap -unit %UNAME% -add 1 H 0 2 192  
auhgmap -unit %UNAME% -add 1 H 0 3 193  
auhgmap -unit %UNAME% -add 1 H 0 4 194  
auhgmap -unit %UNAME% -add 1 H 0 5 195  
auhgmap -unit %UNAME% -add 1 H 0 6 196  
auhgmap -unit %UNAME% -add 1 H 0 7 197  
auhgmap -unit %UNAME% -add 1 H 0 8 198  
auhgmap -unit %UNAME% -add 1 H 0 9 199  
auhgmap -unit %UNAME% -add 1 H 0 10 330  
auhgmap -unit %UNAME% -add 1 H 0 11 331  
auhgmap -unit %UNAME% -add 1 H 0 12 332



```
auhgmap -unit %UNAME% -add 1 H 0 13 333
auhgmap -unit %UNAME% -add 1 H 0 14 334
auhgmap -unit %UNAME% -add 1 H 0 15 335
auhgmap -unit %UNAME% -add 1 H 0 16 336
auhgmap -unit %UNAME% -add 1 H 0 17 337
auhgmap -unit %UNAME% -add 1 H 0 18 338
auhgmap -unit %UNAME% -add 1 H 0 19 339
```

```
auhgmap -unit %UNAME% -add 1 H 0 20 470
auhgmap -unit %UNAME% -add 1 H 0 21 471
auhgmap -unit %UNAME% -add 1 H 0 22 472
auhgmap -unit %UNAME% -add 1 H 0 23 473
auhgmap -unit %UNAME% -add 1 H 0 24 474
auhgmap -unit %UNAME% -add 1 H 0 25 475
auhgmap -unit %UNAME% -add 1 H 0 26 476
auhgmap -unit %UNAME% -add 1 H 0 27 477
auhgmap -unit %UNAME% -add 1 H 0 28 478
auhgmap -unit %UNAME% -add 1 H 0 29 479
```

```
auhgmap -unit %UNAME% -add 0 A 0 100 480
auhgmap -unit %UNAME% -add 0 B 0 100 481
auhgmap -unit %UNAME% -add 0 C 0 100 482
auhgmap -unit %UNAME% -add 0 D 0 100 492
auhgmap -unit %UNAME% -add 0 E 0 100 483
auhgmap -unit %UNAME% -add 0 F 0 100 484
auhgmap -unit %UNAME% -add 0 G 0 100 485
auhgmap -unit %UNAME% -add 0 H 0 100 494
```

```
auhgmap -unit %UNAME% -add 1 A 0 100 486
auhgmap -unit %UNAME% -add 1 B 0 100 487
auhgmap -unit %UNAME% -add 1 C 0 100 488
auhgmap -unit %UNAME% -add 1 D 0 100 493
auhgmap -unit %UNAME% -add 1 E 0 100 489
auhgmap -unit %UNAME% -add 1 F 0 100 490
auhgmap -unit %UNAME% -add 1 G 0 100 491
auhgmap -unit %UNAME% -add 1 H 0 100 495
```

### set\_monitoring

```
aupfmstatiscfg -unit %UNAME% -set -port stop -rglu stop -cache stop -processor stop
-drive stop -driveopr stop -backend stop -managementarea stop
aonlineverify -unit %UNAME% -set -verify disable
ausystuning -unit %UNAME% -set -detailedtrace off
```

### set\_sysparms

```
ausystuning -unit %UNAME% -set -dtystart 20 -dtystop 10
ausystuning -unit %UNAME% -set -loadbalancing disable
```

```
autuningmultistream -unit %UNAME% -default
autuningmultistream -unit %UNAME% -set -scope lu -lu 0-479 -seqcount 0
autuningmultistream -unit %UNAME% -set -scope lu -lu 480-495 -seqcount 1
```

```
autuningmultistream -unit %UNAME% -set -scope lu -lu 0-495 -criteria fixed
```

```
autuningmultistream -unit %UNAME% -set -scope lu -lu 480-495 -readwrite enable
```

### Prepare\_Disks\_forLVs.bat

```
@echo off

if exist "%systemroot%\system32\diskpart.exe" set
dskprt=%systemroot%\system32\diskpart.exe
if "%dskprt%" EQU "" goto END

for /l %%a in (1,1,496) do (

echo select disk %%a>dskprt_script.doc
echo attributes disk clear readonly>>dskprt_script.doc
echo online disk noerr>>dskprt_script.doc
echo convert gpt noerr>>dskprt_script.doc
echo convert dynamic noerr>>dskprt_script.doc
)

%dskprt% -s dskprt_script.doc>%computername%_temp.doc
del dskprt_script.doc

pause

:END
```

## Create\_LVs.bat

```
@echo off

if exist "%systemroot%\system32\diskpart.exe" set
dskprt=%systemroot%\system32\diskpart.exe
if "%dskprt%" EQU "" goto END

rem ASU-1: 10 logical volumes of stripe width 24

echo create volume stripe size=146400
disk=1,125,280,404,32,156,249,373,63,187,311,466,94,218,342,435,21,300,52,269,83,331,1
14,362>dskprt_script.doc
echo assign letter=E >>dskprt_script.doc

echo create volume stripe size=146400
disk=2,126,281,405,33,157,250,374,64,188,312,467,95,219,343,436,22,301,53,270,84,332,1
15,363>>dskprt_script.doc
echo assign letter=F >>dskprt_script.doc

echo create volume stripe size=146400
disk=3,127,282,406,34,158,251,375,65,189,313,468,96,220,344,437,23,302,54,271,85,333,1
16,364>>dskprt_script.doc
echo assign letter=G >>dskprt_script.doc

echo create volume stripe size=146400
disk=4,128,283,407,35,159,252,376,66,190,314,469,97,221,345,438,24,303,55,272,86,334,1
17,365>>dskprt_script.doc
echo assign letter=H >>dskprt_script.doc

echo create volume stripe size=146400
disk=5,129,284,408,36,160,253,377,67,191,315,470,98,222,346,439,25,304,56,273,87,335,1
18,366>>dskprt_script.doc
echo assign letter=I >>dskprt_script.doc
```

```
echo create volume stripe size=146400
disk=11,135,290,414,42,166,259,383,73,197,321,476,104,228,352,445,145,424,176,393,207,
486,238,455>>diskprt_script.doc
echo assign letter=J >>diskprt_script.doc

echo create volume stripe size=146400
disk=12,136,291,415,43,167,260,384,74,198,322,477,105,229,353,446,146,425,177,394,208,
487,239,456>>diskprt_script.doc
echo assign letter=K >>diskprt_script.doc

echo create volume stripe size=146400
disk=13,137,292,416,44,168,261,385,75,199,323,478,106,230,354,447,147,426,178,395,209,
488,240,457>>diskprt_script.doc
echo assign letter=L >>diskprt_script.doc

echo create volume stripe size=146400
disk=14,138,293,417,45,169,262,386,76,200,324,479,107,231,355,448,148,427,179,396,210,
489,241,458>>diskprt_script.doc
echo assign letter=M >>diskprt_script.doc

echo create volume stripe size=146400
disk=15,139,294,418,46,170,263,387,77,201,325,480,108,232,356,449,149,428,180,397,211,
490,242,459>>diskprt_script.doc
echo assign letter=N >>diskprt_script.doc

rem ASU-2: 10 logical volumes of stripe width 24

echo create volume stripe size=146400
disk=6,130,285,409,37,161,254,378,68,192,316,471,99,223,347,440,26,305,57,274,88,336,1
19,367>>diskprt_script.doc
echo assign letter=O >>diskprt_script.doc

echo create volume stripe size=146400
disk=7,131,286,410,38,162,255,379,69,193,317,472,100,224,348,441,27,306,58,275,89,337,
120,368>>diskprt_script.doc
echo assign letter=P >>diskprt_script.doc

echo create volume stripe size=146400
disk=8,132,287,411,39,163,256,380,70,194,318,473,101,225,349,442,28,307,59,276,90,338,
121,369>>diskprt_script.doc
echo assign letter=Q >>diskprt_script.doc

echo create volume stripe size=146400
disk=9,133,288,412,40,164,257,381,71,195,319,474,102,226,350,443,29,308,60,277,91,339,
122,370>>diskprt_script.doc
echo assign letter=R >>diskprt_script.doc

echo create volume stripe size=146400
disk=10,134,289,413,41,165,258,382,72,196,320,475,103,227,351,444,30,309,61,278,92,340
,123,371>>diskprt_script.doc
echo assign letter=S >>diskprt_script.doc

echo create volume stripe size=146400
disk=16,140,295,419,47,171,264,388,78,202,326,481,109,233,357,450,150,429,181,398,212,
491,243,460>>diskprt_script.doc
echo assign letter=T >>diskprt_script.doc

echo create volume stripe size=146400
disk=17,141,296,420,48,172,265,389,79,203,327,482,110,234,358,451,151,430,182,399,213,
492,244,461>>diskprt_script.doc
echo assign letter=U >>diskprt_script.doc
```

```
echo create volume stripe size=146400
disk=18,142,297,421,49,173,266,390,80,204,328,483,111,235,359,452,152,431,183,400,214,
493,245,462>>dskprt_script.doc
echo assign letter=V >>dskprt_script.doc

echo create volume stripe size=146400
disk=19,143,298,422,50,174,267,391,81,205,329,484,112,236,360,453,153,432,184,401,215,
494,246,463>>dskprt_script.doc
echo assign letter=W >>dskprt_script.doc

echo create volume stripe size=146400
disk=20,144,299,423,51,175,268,392,82,206,330,485,113,237,361,454,154,433,185,402,216,
495,247,464>>dskprt_script.doc
echo assign letter=X >>dskprt_script.doc

rem ASU-3: 1 logical volume

echo create volume stripe size=488000
disk=31,155,310,434,62,186,279,403,93,217,341,496,124,248,372,465>>dskprt_script.doc
echo assign letter=Y >>dskprt_script.doc

%dskprt% -s dskprt_script.doc>%computername%_temp_out.doc

del dskprt_script.doc

pause

:END
```

## APPENDIX D: SPC-1 WORKLOAD GENERATOR STORAGE COMMANDS AND PARAMETERS

### ASU Pre-Fill

The content of command and parameter file, used in this benchmark to execute the required ASU pre-fill, is listed below.

```
compratio=1
sd=sd1,lun=\\.E:,threads=16
sd=sd2,lun=\\.F:,threads=16
sd=sd3,lun=\\.G:,threads=16
sd=sd4,lun=\\.H:,threads=16
sd=sd5,lun=\\.I:,threads=16
sd=sd6,lun=\\.J:,threads=16
sd=sd7,lun=\\.K:,threads=16
sd=sd8,lun=\\.L:,threads=16
sd=sd9,lun=\\.M:,threads=16
sd=sd10,lun=\\.N:,threads=16
sd=sd11,lun=\\.O:,threads=16
sd=sd12,lun=\\.P:,threads=16
sd=sd13,lun=\\.Q:,threads=16
sd=sd14,lun=\\.R:,threads=16
sd=sd15,lun=\\.S:,threads=16
sd=sd16,lun=\\.T:,threads=16
sd=sd17,lun=\\.U:,threads=16
sd=sd18,lun=\\.V:,threads=16
sd=sd19,lun=\\.W:,threads=16
sd=sd20,lun=\\.X:,threads=16
sd=sd21,lun=\\.Y:,threads=16

wd=wd1,sd=sd1,rdpct=0,seek=-1,xfersize=1m
wd=wd2,sd=sd2,rdpct=0,seek=-1,xfersize=1m
wd=wd3,sd=sd3,rdpct=0,seek=-1,xfersize=1m
wd=wd4,sd=sd4,rdpct=0,seek=-1,xfersize=1m
wd=wd5,sd=sd5,rdpct=0,seek=-1,xfersize=1m
wd=wd6,sd=sd6,rdpct=0,seek=-1,xfersize=1m
wd=wd7,sd=sd7,rdpct=0,seek=-1,xfersize=1m
wd=wd8,sd=sd8,rdpct=0,seek=-1,xfersize=1m
wd=wd9,sd=sd9,rdpct=0,seek=-1,xfersize=1m
wd=wd10,sd=sd10,rdpct=0,seek=-1,xfersize=1m

wd=wd11,sd=sd11,rdpct=0,seek=-1,xfersize=1m
wd=wd12,sd=sd12,rdpct=0,seek=-1,xfersize=1m
wd=wd13,sd=sd13,rdpct=0,seek=-1,xfersize=1m
wd=wd14,sd=sd14,rdpct=0,seek=-1,xfersize=1m
wd=wd15,sd=sd15,rdpct=0,seek=-1,xfersize=1m
wd=wd16,sd=sd16,rdpct=0,seek=-1,xfersize=1m
wd=wd17,sd=sd17,rdpct=0,seek=-1,xfersize=1m
wd=wd18,sd=sd18,rdpct=0,seek=-1,xfersize=1m
wd=wd19,sd=sd19,rdpct=0,seek=-1,xfersize=1m
wd=wd20,sd=sd20,rdpct=0,seek=-1,xfersize=1m

wd=wd21,sd=sd21,rdpct=0,seek=-1,xfersize=1m

rd=asu_prefill,wd=wd*,iorate=max,elapsed=100h,interval=10
```

## Primary Metrics and Repeatability Tests

The content of SPC-1 Workload Generator command and parameter file, used in this benchmark to execute the Primary Metrics and Repeatability Tests, is listed below.

```
javaparms="-Xmx1280m -Xss256k"

# For ASU-1

sd=asu1_1,lun=\\.\E:,size=3431g
sd=asu1_2,lun=\\.\F:,size=3431g
sd=asu1_3,lun=\\.\G:,size=3431g
sd=asu1_4,lun=\\.\H:,size=3431g
sd=asu1_5,lun=\\.\I:,size=3431g
sd=asu1_6,lun=\\.\J:,size=3431g
sd=asu1_7,lun=\\.\K:,size=3431g
sd=asu1_8,lun=\\.\L:,size=3431g
sd=asu1_9,lun=\\.\M:,size=3431g
sd=asu1_10,lun=\\.\N:,size=3431g

# For ASU-2

sd=asu2_1,lun=\\.\O:,size=3431g
sd=asu2_2,lun=\\.\P:,size=3431g
sd=asu2_3,lun=\\.\Q:,size=3431g
sd=asu2_4,lun=\\.\R:,size=3431g
sd=asu2_5,lun=\\.\S:,size=3431g
sd=asu2_6,lun=\\.\T:,size=3431g
sd=asu2_7,lun=\\.\U:,size=3431g
sd=asu2_8,lun=\\.\V:,size=3431g
sd=asu2_9,lun=\\.\W:,size=3431g
sd=asu2_10,lun=\\.\X:,size=3431g

# For ASU-3

sd=asu3_1,lun=\\.\Y:,size=7625g
```

## SPC-2 Persistence Test

The content of SPC-2 Workload Generator command and parameter files, used in this benchmark to execute the SPC-2 Persistence Test, are listed below.

### SPC-2 Persistence Test Run 1 (*write phase*)

```
host=localhost,jvms=1,maxstreams=200

sd=sd1,lun=\\.\E:,size=343100000000
sd=sd2,lun=\\.\F:,size=343100000000
sd=sd3,lun=\\.\G:,size=343100000000
sd=sd4,lun=\\.\H:,size=343100000000
sd=sd5,lun=\\.\I:,size=343100000000
sd=sd6,lun=\\.\J:,size=343100000000
sd=sd7,lun=\\.\K:,size=343100000000
sd=sd8,lun=\\.\L:,size=343100000000
sd=sd9,lun=\\.\M:,size=343100000000
sd=sd10,lun=\\.\N:,size=343100000000
sd=sd11,lun=\\.\O:,size=343100000000
sd=sd12,lun=\\.\P:,size=343100000000
```

```
sd=sd13,lun=\\.Q:,size=3431000000000
sd=sd14,lun=\\.R:,size=3431000000000
sd=sd15,lun=\\.S:,size=3431000000000
sd=sd16,lun=\\.T:,size=3431000000000
sd=sd17,lun=\\.U:,size=3431000000000
sd=sd18,lun=\\.V:,size=3431000000000
sd=sd19,lun=\\.W:,size=3431000000000
sd=sd20,lun=\\.X:,size=3431000000000
sd=sd21,lun=\\.Y:,size=7625000000000

maxlatestart=1
reportinginterval=5
segmentlength=512m

rd=default,rampup=180,periods=90,measurement=300,runout=0,rampdown=0,buffers=1
rd=default,rdpct=0,xfersize=1024k
rd=TR1-200s_SPC-2-persist-w,streams=200
```

### SPC-2 Persistence Test Run 2 (*read phase*)

```
host=localhost,jvms=1,maxstreams=200

sd=sd1,lun=\\.E:,size=3431000000000
sd=sd2,lun=\\.F:,size=3431000000000
sd=sd3,lun=\\.G:,size=3431000000000
sd=sd4,lun=\\.H:,size=3431000000000
sd=sd5,lun=\\.I:,size=3431000000000
sd=sd6,lun=\\.J:,size=3431000000000
sd=sd7,lun=\\.K:,size=3431000000000
sd=sd8,lun=\\.L:,size=3431000000000
sd=sd9,lun=\\.M:,size=3431000000000
sd=sd10,lun=\\.N:,size=3431000000000
sd=sd11,lun=\\.O:,size=3431000000000
sd=sd12,lun=\\.P:,size=3431000000000
sd=sd13,lun=\\.Q:,size=3431000000000
sd=sd14,lun=\\.R:,size=3431000000000
sd=sd15,lun=\\.S:,size=3431000000000
sd=sd16,lun=\\.T:,size=3431000000000
sd=sd17,lun=\\.U:,size=3431000000000
sd=sd18,lun=\\.V:,size=3431000000000
sd=sd19,lun=\\.W:,size=3431000000000
sd=sd20,lun=\\.X:,size=3431000000000
sd=sd21,lun=\\.Y:,size=7625000000000

maxlatestart=1
reportinginterval=5
segmentlength=512m
maxpersistenceerrors=10

rd=default,buffers=1,rdpct=100,xfersize=1024k
rd=TR1-200s_SPC-2-persist-r
```

## **APPENDIX E: SPC-1 WORKLOAD GENERATOR INPUT PARAMETERS**

### **ASU Pre-Fill, Primary Metrics Test, Repeatability Test and Persistence Test Run 1**

The following script was used to execute the required ASU pre-fill (prefill.bat), Primary Metrics Test (*Sustainability Test Phase, IOPS Test Phase, and Response Time Ramp Test Phase*), Repeatability Test (*Repeatability Test Phase 1 and Repeatability Test Phase 2*), and Persistence Test Run 1 (spc2.bat) in an uninterrupted sequence.

```
set LIBPATH=C:\spc\spc1\spc1v23;C:\spc\spc1;C:\spc\spc2
set CLASSPATH=C:\spc\spc1\spc1v23;C:\spc\spc1;C:\spc\spc2
set BSU=2200
set XMS=1280m
set XMX=1280m
set XSS=96k

cd c:\vdbench503rc11

call prefill.bat

cd c:\spc\spc1\spc1v23

java -Xms%XMS% -Xmx%XMX% -Xss%XSS% metrics -t 28800 -b %BSU%
java -Xms%XMS% -Xmx%XMX% -Xss%XSS% repeat1 -b %BSU%
java -Xms%XMS% -Xmx%XMX% -Xss%XSS% repeat2 -b %BSU%

cd C:\spc\spc2

call spc2.bat -f persist1.cfg -o init -init
call spc2.bat -f persist1.cfg -o persist1
```

#### **prefill.bat**

```
cd c:\vdbench503rc11
vdbench -f prefill_all.parm -o prefill-out
```



## Persistence Test Run 2

The following script was used to execute Persistence Test Run 2.

```
set LIBPATH=C:\spc\spc1\spc1v23;C:\spc\spc1;C:\spc\spc2
set CLASSPATH=C:\spc\spc1\spc1v23;C:\spc\spc1;C:\spc\spc2
set BSU=2200
set XMS=1280m
set XMX=1280m
set XSS=96k
```

```
cd C:\spc\spc2
```

```
call spc2.bat -f persist2.cfg -o persist2
```

### spc2.bat

```
@echo off

rem Windows: start Vdbench

rem Directory where this is executed from:
set dir=%~dp0

rem set current class path
set cp=%~dp0

set java=java

%java% -Xmx1536m -Xms512m -Xss96k -cp %cp% vdbench %*
```

**APPENDIX F: THIRD-PARTY QUOTATIONS**

**Brocade 360 FC Switch**

  
**BROCADE**

09/13/13

TO: Kien Tran

RE: HDS QUOTE

POs should be e-mailed to: [HDS-OMDistribution@brocade.com](mailto:HDS-OMDistribution@brocade.com)

Product	Description	QTY	HDS PRICE	Total
HD-360-0008	Brocade 360 switch w/ 24 active ports, Full Fabric, 24 SWL 8Gb BR SFPs, Fixed Rack Mount	1	\$ 4,827.00	\$ 4,827.00
(-M)	13 mos maintenance	1	\$ 107.00	\$ 107.00
HD-360-0008	Brocade 360 switch w/ 24 active ports, Full Fabric, 24 SWL 8Gb BR SFPs, Fixed Rack Mount	1	\$ 4,827.00	\$ 4,827.00
(-M)	3 year support	1	\$ 320.00	\$ 320.00
				\$ -
<b>Total</b>				<b>\$ 10,081.00</b>

Yadira Aparicio  
Account Manager  
Brocade Communications

**Emulex LPE12002-E LightPulse Dual Port FC HBAs and FC Cables**

 <p><b>Celebrating 22 Years!</b></p> <p><b>DeltaWare</b> INCORPORATED</p>		<h1>Quotation</h1> <table border="1"> <tr> <th>Quote #</th> <th>Date</th> </tr> <tr> <td>60207</td> <td>02/18/2013</td> </tr> <tr> <th colspan="2">Sales Rep</th> </tr> <tr> <td colspan="2">Paul Albright 210-691-1715</td> </tr> </table>		Quote #	Date	60207	02/18/2013	Sales Rep		Paul Albright 210-691-1715													
Quote #	Date																						
60207	02/18/2013																						
Sales Rep																							
Paul Albright 210-691-1715																							
<table border="1"> <tr> <th>For</th> <th>Customer #/S1167</th> <th>Phones</th> </tr> <tr> <td>Kien Tran HITACHI Data Systems 2845 Lafayette Street Accounts Payable Santa Clara CA 95050-2627</td> <td></td> <td>Wk 408-327-                      mwk 408-327-4282 Cel 561-889-6000</td> </tr> <tr> <td></td> <td></td> <td> <table border="1"> <tr> <th>PO #</th> <th>Terms</th> <th>Ship Date</th> <th>Ship Via</th> </tr> <tr> <td></td> <td>NET 30</td> <td></td> <td></td> </tr> </table> </td> </tr> </table>		For	Customer #/S1167	Phones	Kien Tran HITACHI Data Systems 2845 Lafayette Street Accounts Payable Santa Clara CA 95050-2627		Wk 408-327-                      mwk 408-327-4282 Cel 561-889-6000			<table border="1"> <tr> <th>PO #</th> <th>Terms</th> <th>Ship Date</th> <th>Ship Via</th> </tr> <tr> <td></td> <td>NET 30</td> <td></td> <td></td> </tr> </table>	PO #	Terms	Ship Date	Ship Via		NET 30							
For	Customer #/S1167	Phones																					
Kien Tran HITACHI Data Systems 2845 Lafayette Street Accounts Payable Santa Clara CA 95050-2627		Wk 408-327-                      mwk 408-327-4282 Cel 561-889-6000																					
		<table border="1"> <tr> <th>PO #</th> <th>Terms</th> <th>Ship Date</th> <th>Ship Via</th> </tr> <tr> <td></td> <td>NET 30</td> <td></td> <td></td> </tr> </table>	PO #	Terms	Ship Date	Ship Via		NET 30															
PO #	Terms	Ship Date	Ship Via																				
	NET 30																						
<table border="1"> <thead> <tr> <th></th> <th>Part</th> <th>Description</th> <th>Qty</th> <th>Price</th> <th>Extended</th> </tr> </thead> <tbody> <tr> <td>1)</td> <td>LPE12002-E</td> <td>EMC LightPulse Dual Port Fibre Channel Host Bus Adapter 8GB 2PORT FC PCI EXPRESS 2 x LC - PCI Express 2.0 - 8Gbps</td> <td>2</td> <td>1,295.00</td> <td>2,590.00</td> </tr> <tr> <td>2)</td> <td>2-LCLC-Z50RT-010F</td> <td>2-LCLC-Z50RT-010F - 10FR LC - LC MM - 50 Standard</td> <td>4</td> <td>21.25</td> <td>85.00</td> </tr> </tbody> </table>							Part	Description	Qty	Price	Extended	1)	LPE12002-E	EMC LightPulse Dual Port Fibre Channel Host Bus Adapter 8GB 2PORT FC PCI EXPRESS 2 x LC - PCI Express 2.0 - 8Gbps	2	1,295.00	2,590.00	2)	2-LCLC-Z50RT-010F	2-LCLC-Z50RT-010F - 10FR LC - LC MM - 50 Standard	4	21.25	85.00
	Part	Description	Qty	Price	Extended																		
1)	LPE12002-E	EMC LightPulse Dual Port Fibre Channel Host Bus Adapter 8GB 2PORT FC PCI EXPRESS 2 x LC - PCI Express 2.0 - 8Gbps	2	1,295.00	2,590.00																		
2)	2-LCLC-Z50RT-010F	2-LCLC-Z50RT-010F - 10FR LC - LC MM - 50 Standard	4	21.25	85.00																		
<p>Thank you, Paul Albright</p> <p>Quotes are valid for 30 days. 4730 Shavano Oak Suite 215 San Antonio, Texas 78249</p>																							
<table border="1"> <tr> <td><b>Subtotal</b></td> <td>2,675.00</td> </tr> <tr> <td><b>TOTAL</b></td> <td><b>\$2,675.00</b></td> </tr> </table>					<b>Subtotal</b>	2,675.00	<b>TOTAL</b>	<b>\$2,675.00</b>															
<b>Subtotal</b>	2,675.00																						
<b>TOTAL</b>	<b>\$2,675.00</b>																						